

# Effect of Rushton Impeller Speed on Biogas Production in Anaerobic Digestion of Continuous Stirred Bioreactor

*by* Nazaruddin Sinaga

---

**Submission date:** 15-Dec-2019 01:48PM (UTC+0700)

**Submission ID:** 1234714042

**File name:** erobic\_Digestion\_of\_Continuous\_Stirred\_Bioreactor\_-\_turnitin.pdf (921.13K)

**Word count:** 3052

**Character count:** 15369



## Journal of Advanced Research in Biofuel and Bioenergy

Journal homepage: [www.akademiabaru.com/arbb.html](http://www.akademiabaru.com/arbb.html)  
ISSN: 2600-8459



### Effect of Rushton Impeller Speed on Biogas Production in Anaerobic Digestion of Continuous Stirred Bioreactor

Open  
Access

Nazaruddin Sinaga<sup>1,\*</sup>, Kurnia Hatta<sup>1</sup>, Nurjehan Ezzatul Ahmad<sup>2</sup>, Maizirwan Mel<sup>2</sup>

#### 1. Introduction

The anaerobic digestion process is the process of forming biogas from organic mineral compounds involving many types of microorganisms and takes place in conditions without air. This widely applied digestion is a complex biochemical process because it consists of several stages of formation to finally produce biogas. These stages are hydrolysis, acidogenesis, acetogenesis, and methanogenesis [1,2]. These processes break organic mineral compounds such as proteins, carbohydrates, and fats into acidic compounds and so on to form methane gas. At each stage of anaerobic digestion also requires different bacteria such as acetogen bacteria (degrade propionate and butyrate) and methanogen (degrade acetate).

\* Corresponding author.

E-mail address: [nsinaga.ccfed@yahoo.com](mailto:nsinaga.ccfed@yahoo.com) (Nazaruddin Sinaga)

In this fermentation process, there are special stages where some organic compounds that have been broken down must go through that stage, while some other organic compounds do not need to go through it. This particular process is known as syntrophic interactions [3]. Syntrophic reactions are reactions that have a dependence on the results of previous reactions. This process occurs in the acetogenesis stage towards methanogenesis. Propionate and butyrate results from the acidogenesis process cannot be oxidized directly into methane so it must go through the process of acetogenesis to form acetate [4]. This research on the anaerobic syntrophic digestion process has not been much encouraged theoretically. Most research is carried out experimentally in a stirred bioreactor. Studies like this are quite complicated because they have to separate the results of propionate and butyrate first, then stir it together with the bacteria obtained from different reactors. The experimental method indeed requires much equipment at a much cost too.

As is well known, one of the methods currently used to solve the problem of kinetics reactions is numerical methods. At present, there are several computational fluid dynamics (CFD) application programs that facilitate solving problems of mass transfer, momentum, energy, chemical reactions, phase changes, and so on. All of this is done by solving various mathematical equations that are appropriate for modeling processes related to mass transfer, momentum, energy, species, and phase [5,6]. Also, by using CFD simulations, the research costs become cheaper.

Anaerobic digestion simulation using CFD has been performed for many problems [7,8], but there was only a few research that studies about numerical calculation of biogas production in complete syntrophic reactions. Most numerical modeling is carried out for two phases in two dimensions field. From the literature review, it is also known that stirring can accelerate the process of anaerobic digestion. Some literature shows that the rate of biogas production in a stirred digester is higher than without a stirrer [9,10].

This research will simulate a three-phase and three-dimensional syntrophic anaerobic digestion process in a continuous stirred anaerobic bioreactor numerically. The primary objective of this study is to understand deeply about the mixing process and the effect of mixer rotational speed on the biogas production rate. To find out the accuracy of the calculation results, a validity test with the results of experiments obtained from the literature will be conducted [11].

The simulation process is performed by modeling the actual conditions in the form of chemical reactions occurs at the syntrophic stage. The reaction was calculated under mesophile conditions by modeling the liquid-gas-solid phase. The variations in the rotational speed of the impellers observed were 50, 70, 100, 150, 200, and 300 rpm.

## 2. Methodology

### 2.1 Experimental Tests

The result from Amani [12] experimental was used as a reference for this study where the anaerobic syntrophic digestion process, which using acetogen and methanogen bacteria from pure milk waste have been investigated. The microorganisms were obtained by electrolyzing waste milk in an up-flow anaerobic sludge bed (UASB) reactor. The bacteria produced were used to break propionate acid (1500 mg / L), butyric acid (2000 mg / L) and acetic acid (2500 mg / L), which are volatile fatty acids (VFA). The process takes at temperature of 27°C in a small bioreactor with a diameter of 125 mm and a height of 165 mm, and with a substrate volume of 2000 ml. The Rushton impeller type mixer is chosen to accelerate the digestion process. Stirring is carried out continuously at an impeller speed of 100 rpm. The results of this process are propionate, butyrate, and degraded acetate and biogas.

## 2.2 Numerical Modeling

### 2.2.1 Eulerian multi phase modeling

In multi-phase flow, a phase is defined as a material that has an inertial response and interacts with the flow and potential field. For example, the same solid particles which have different sizes can be treated as different phases, because a group of particles of the same size has the same dynamic response to the flow field [13]. The multi-phase Eulerian model works by solving momentum and continuity equations for each phase. Solving these equations depends on the type of mixture phase used, whether the flow is granular (fluid-solid) or non-granular flow (fluids). Both types are very different. For granular flow, the properties of the flow can be obtained by the kinetic theory. The multi-phase Eulerian model allows separate multi-phase modeling but still have inter-phase interaction. Phases can involve liquids, gases, solids, or combinations between phases. Euler treatment is used for each stage. The multi-phase Eulerian equation is completed sequentially; then the non-linear equation is linearized to produce the dependent variable equation in each calculation. The resulting linear system is then broken down to produce a flow-field solution.

An implicit linear point (Gauss-Seidel) as a solver equation is used in the relationship of multi-grid methods to solve scalar equations resulting from the dependent variable equations in each cell. The depiction of the continuous multi-phase flow includes the volume fraction represented by  $\alpha_j$ . The volume fraction represents the space occupied by each phase, and the conservation equation of mass and momentum is fulfilled by each phase freely [11]. The continuity equation for phase-j is:

$$\frac{\partial}{\partial t} (\alpha_i \rho_i) + \nabla \cdot (\alpha_i \rho_i \vec{v}_i) = 0 \quad (1)$$

where  $\vec{v}_j$  is the phase-j velocity. General momentum equation for phase-j is:

$$\frac{\partial}{\partial t} (\alpha_i \rho_i \vec{v}_i) + \nabla \cdot (\alpha_i \rho_i \vec{v}_i \vec{v}_i) = -\alpha_i \nabla p + \nabla \cdot \bar{\tau}_i + \alpha_i \rho_i \vec{g} + \sum_{i=1}^n \vec{R}_{ji} + \alpha_i \rho_i (\vec{F}_i) \quad (2)$$

Where  $\bar{\tau}_i$  is the shear stress for phase-j.

$$\bar{\tau}_i = \alpha_i \mu_i (\nabla \vec{v}_i + \vec{v}_i^T) + \alpha_i \left( \lambda_i - \frac{2}{3} \mu_i \right) \nabla \cdot \vec{v}_i \vec{I} \quad (3)$$

### 2.2.2 Inter-phase momentum transfer

The theory of momentum transfer between phases only applies to non-homogeneous multi-phase flows. Because, when using a homogeneous model, the momentum transfer between each phase would be very high [14]. In this study a simple momentum transfer is modeled with the equation [11]:

$$\sum_{j=1}^n \vec{R}_{ji} = \sum_{i=1}^n K_{ji} (\vec{v}_i - \vec{v}_j) \quad (4)$$

The the inter-phase momentum transfer coefficient might be written as follows:

$$K_{ji} = \frac{\alpha_i \alpha_j \rho_j f}{\tau_j} \quad (5)$$

Where  $f$  is a drag function and  $\tau_i$  is the particulate relaxation time which can be determined from:

$$\tau_j = \frac{\rho_j d_j^2}{18\mu_i} \quad (6)$$

### 2.2.3 Turbulence model $k$ - $\varepsilon$ RNG

In this study, the  $k$ - $\varepsilon$  RNG turbulence model was chosen. This model is more accurate than the standard  $k$ -epsilon but requires more time for iteration. Also, this model is also more suitable for low Reynold numbers. There are two turbulent model equations used to calculate the kinetic and dissipation energy, which are as follows

$$\frac{\partial}{\partial t} (\rho_m k) + \nabla \cdot (\rho_m \vec{v}_m k) = \nabla \cdot \left( \frac{\mu_{t,m}}{\sigma_k} \nabla k \right) + G_{k,m} - \rho_m \varepsilon \quad (7)$$

$$\frac{\partial}{\partial t} (\rho_m \varepsilon) + \nabla \cdot (\rho_m \vec{v}_m \varepsilon) = \nabla \cdot \left( \frac{\mu_{t,m}}{\sigma_\varepsilon} \nabla \varepsilon \right) + c_{1\varepsilon} G_{k,m} - c_{2\varepsilon} \rho_m \varepsilon \quad (8)$$

With the standard constant numbers:

$$c_\mu = 0.0845, c_{1\varepsilon} = 1.42, c_{2\varepsilon} = 1.68, \sigma_k = 1.0, \sigma_\varepsilon = 1.3$$

### 2.2.4 Equations of species transport

Species transport equation is used to solve the conservation equations of chemical species. ANSYS Fluent can predict the local mass fraction of each species of convection-diffusion equation for each species. This conservation equation takes the following general form [14] of:

$$\frac{\partial}{\partial t} (\rho Y_i) + \nabla \cdot (\rho \vec{v} Y_i) = -\nabla \cdot \vec{J}_i + R_i + S_i \quad (9)$$

This equation solves each species from the total liquid species that enter the system. Therefore, the mass fraction of the species must be one, and the mass fraction that has not been known can be determined from the fraction obtained from the calculated mass fraction. To minimize numerical errors, the species should be selected as a species that has the highest mass fraction [14].

## 2.3 Simulation Procedure

### 2.3.1 Geometry and mesh generation

The bioreactor used is designed to be in a closed vessel, with geometry and dimensions as shown in Figure 1. Components of the bioreactor are set to have one inlet, two outlets, and walls. For the initial model, the geometry was meshing with around 100,000 cell number with a tetrahedron topology. In this simulation, the impeller moves rotationally in a multiple reference frame (MRF).

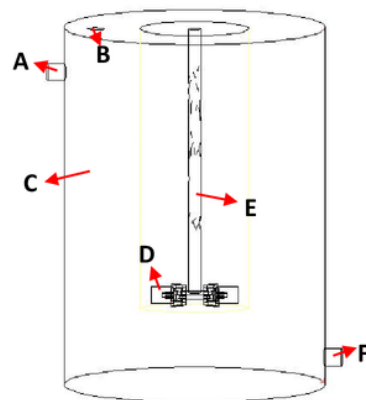

Fig. 1. Geometry of bioreactor

**Table 1**  
Bioreactor dimensions

Codes	Bioreactor parts	Dimensions
A	Inlet	D:8 mm; L:8 mm ; h:150 mm
B	Outlet biogas	D:8 mm; L:8 mm ;
C	Bioreactor tank	D:120 mm; h:165 mm
D	Rushton Turbine	D <sub>i</sub> :40 mm; D <sub>o</sub> :30 mm, h:10 mm; h:8 mm; t:2 mm
E	Shaft	D:6 mm; h:120 mm
F	Outlet	D:8 mm; L:8 mm ; t:8 mm

### 2.3.2 CFD simulations

There are so many variables and models that have to be set when running the simulation process. One necessary setting is to establish material characteristics as shown in Table 2. For validation purposes, these material properties are the same as used in the literature [11].

**Table 2**  
Material properties

Species	Density (kg/m)	Heat capacity (j/kg)	Molecular weight (g/mol)	Standard state enthalpy (kj/kmol)	Standard state enthalpy (kj/kmol/k)
Acetic acid	1049	2016	60.05	-483,880	158,00
Butyric acid	959.5	2020	88.11	-533,900	226.30
Carbon dioxide	1.98	480	44.01	-393,532	213.72
Hydrogen	0.09	14,283	2.02	0	130.58
Methane	0.66	2222	16.04	-74,895	186.04
Propionic acid	990	2038	74.08	510,000	191.00
Water	998	4182	18.01	-285,841	69.90
Sludge	1250	-	-	-	-

In the simulation, the input material must be in the form of a mixture. Acetate, butyrate, propionate, and water are mixed with the name of wastewater, whose composition is more than others. Likewise for biogas, which is a mixture of methane, hydrogen and carbon dioxide. All the mixtures are simulated with the rules of mixing law. In the Eulerian multiphase section, each material is regulated following the reaction as shown in Table 3.

**Table 3**  
 Reaction of Volatile Fatty Acid

Process	Reaction
Acidogenic reaction	$\text{CH}_3\text{CH}_2\text{COOH} + 2\text{H}_2\text{O} \rightarrow \text{CH}_3\text{COOH} + \text{CO}_2 + 3\text{H}_2$
Acetogenic reaction	$\text{CH}_3\text{CH}_2\text{CH}_2\text{COOH} + 2\text{H}_2\text{O} \rightarrow 2\text{CH}_3\text{COOH} + 2\text{H}_2$
Methanogenesis reaction	$\text{CH}_3\text{COOH} \rightarrow \text{CO}_2 + \text{H}_2$

In this study, each reaction is governed by the kinetic parameters of each process. These parameters are summarized as shown in Table 4 [11]. The mass fraction, at the velocity inlet and pressure outlet of the liquid phase (wastewater), for propionate, butyrate, and acetate are 0.0015, 0.0020 and 0.0025, respectively. The volume fraction is given to the sludge is 0.0200.

**Table 4**  
 Kinetical parameters

Degradation factor	Reaction rates ((kmol/m <sup>3</sup> ) <sup>1-n</sup> /s)	Activation energy (J/kmol)
Propionic acid	2,60417E-07	4323
Butyric acid	2,08333E-07	7199,9
Acetic acid	4,62963E-07	5696,1

Following the actual digestion process, the simulation is carried out in a transient mode, with a time step of 0.01 second. The operating conditions applied in this simulation are at a pressure of 101,325 Pa and temperature of 37 °C, while the gravity effect is activated with a value of 9.81 m/s<sup>2</sup>. In the cell-zone condition section, the MRF method is activated by inputting the mixer speed as 50, 70, 100, 150, 200 and 300 rpm. The phase coupled SIMPLE is applied for the pressure-velocity-coupling scheme, with the least-square-cell-based is chosen as spatial-discretization gradient. The value of under-relaxation factors used to control the course of the simulation is shown in Table 5. The convergence criteria for all iterated variables is 1E-3, with consideration that the simulations take not so long time, but the results are still quite accurate.

**Table 5**  
 Under relaxation factors

Under Relaxation Factors	Values
Pressure	0.6
Density	1
Body force	1
Momentum	0.7
Volume fraction	0.6
Turbulent kinetic energy	0.6
Turbulent dissipation rate	0.6

### 3 Results and Discussion

#### 3.1 Grid independence test and validation

Table 6 shows the grid independence test based on the calculation of biogas concentration. Tests are carried out from cell numbers of 100,000 to 300,000. It can be seen that for cell number larger than 250,000, the changes in the calculation result is not significant. Therefore for this study, all simulations are carried out with 250,000 cell number.

**Table 6**  
Grid independence test

Number of Cell	Velocity Magnitude (m/s)	Error (%)
100000	0,0059	0,87
150000	0,00596	9,83
200000	0,00661	1,93
250000	0,00674	0,75
300000	0,00669	-

Before calculating the effect of mixer speed variations, this section shows the validation of the calculated propionate concentration degradation to measurement results [11]. Table 7 shows the validation results for several intervals of digestion time. It is clear that the calculation results of propionate degradation are in good agreement with the measurement.

**Table 7**  
Validation results

Time (s)	Propionate concentration		Error
	Experiment (mg/L)	Simulation (mg/L)	
100	150,008,462	149,734,148	0,18%
120	150,010,154	149,733,889	0,18%
140	150,011,846	1,497,339,926	0,18%
160	150,013,539	149,733,585	0,18%

#### 3.2. Discussion

##### 3.2.1. Volume Fraction

The volume fraction shows the area of the position of each phase, namely solid liquid and gas. As shown in Figure 2, it can be seen that the solid phase (sludge) is in the lowest area, because the density of sludge is higher than that of wastewater. The liquid phase (wastewater) shown in Figure 3 is in the middle area or between sludge and biogas because the density of wastewater is higher than that of biogas. The biogas, as shown in Figure 4, is in the top area because it has a lower density compared to wastewater.

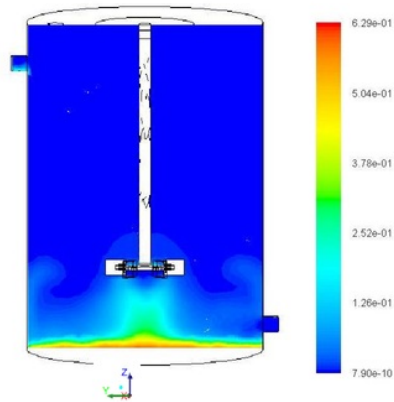

**Fig. 2.** Volume fraction of sludge

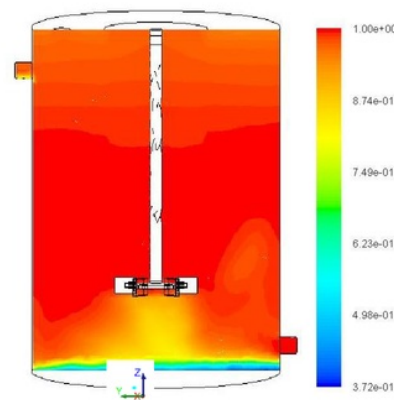

**Fig. 3.** Volume fraction of wastewater

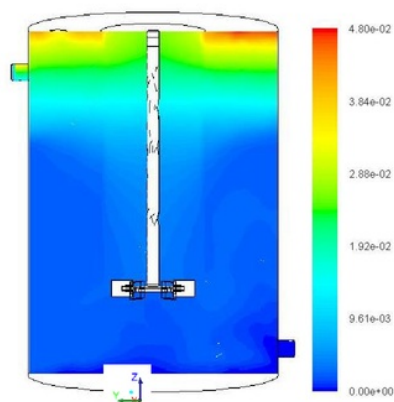

**Fig. 4.** Volume fraction of biogas

### 3.2.2. Biogas production

Biogas is the most essential product of anaerobic digestion. In this simulation, biogas is separated into methane, carbon dioxide, and hydrogen. From the simulation, it was found that the effect of rotation speed on methane production turned out to be different. As shown in Figure 5a, the large impeller rotational speed, which is 300 rpm, does not necessarily increase biogas production but decreases its production rate. At a rotation that is too low, which is 50 rpm, it turns out the production rate is much lower than the speed of 200 rpm.

The effect of mixer rotational speed on carbon dioxide production is not much different from that experienced by methane, as shown in Figure 5b. The higher rotational speed does not necessarily increase the production of carbon dioxide. It can be seen that the highest carbon dioxide production rate is achieved at 200 rpm.

When compared with hydrogen production, the longer the digestion time, the lower the production rate. This is because hydrogen is not the primary product of the methanogenesis, but is in the acetogenesis stage. If there is less hydrogen in the mixture then the quality of the biogas produced is better. If seen from Figure 5c, the fastest decrease in hydrogen production occurs at a speed of 200 rpm, while a late decline occurs at a speed of 300 rpm. From these results, it can be concluded that high rotational speed does not necessarily accelerate biogas production, but there is an optimum speed where the reaction can run more productively.

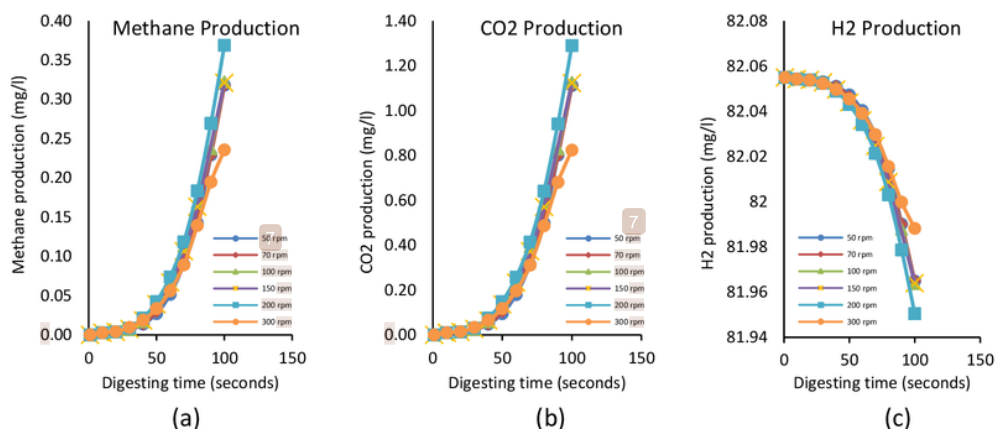

Fig. 5. Production rate of: (a) methane, (b) CO<sub>2</sub> and (c) H<sub>2</sub>

## 4. Conclusions

Based on this study, it can be concluded that the computational solution of the syntrophic anaerobic digestion process provides excellent results. This result is proven by comparing the calculation with the measurement results of propionate degradation, where the difference is only about 0.18%. Another conclusion is that the mixer rotational speed has a significant effect on the biogas production rate. It also concludes that there is an optimum rotational speed value which gives the highest biogas production rate. From all calculated speed variations, the highest rate of biogas production is reached at a speed of 200 rpm, which produce the highest rate of both methane and carbon dioxide production but with low of hydrogen.



# Effect of Rushton Impeller Speed on Biogas Production in Anaerobic Digestion of Continuous Stirred Bioreactor

## ORIGINALITY REPORT

7%

SIMILARITY INDEX

4%

INTERNET SOURCES

4%

PUBLICATIONS

5%

STUDENT PAPERS

## PRIMARY SOURCES

- |   |                                                                                                                                                                                                          |    |
|---|----------------------------------------------------------------------------------------------------------------------------------------------------------------------------------------------------------|----|
| 1 | <a href="http://www.scribd.com">www.scribd.com</a><br>Internet Source                                                                                                                                    | 1% |
| 2 | Submitted to Cranfield University<br>Student Paper                                                                                                                                                       | 1% |
| 3 | <a href="http://ethesis.nitrkl.ac.in">ethesis.nitrkl.ac.in</a><br>Internet Source                                                                                                                        | 1% |
| 4 | Submitted to University of Sheffield<br>Student Paper                                                                                                                                                    | 1% |
| 5 | Yuzhen Jin, Jingyu Cui, Xiangdong Li, Hongli Chen. "An investigation on the distribution of massive fiber granules in rotor spinning units", <i>Textile Research Journal</i> , 2016<br>Publication       | 1% |
| 6 | Latha Shanmugam, Velraj Ramalingam, Shanmugam Palaniyandi, Sivanesan Subramanian. "Comparison of different mixing phenomena in anaerobic digestion using food waste and sewage treatment plant for green | 1% |

biofuel through simulations of velocity contours",  
Energy Sources, Part A: Recovery, Utilization,  
and Environmental Effects, 2018

Publication

---

**7** Hashem Alkhalidi, Peter Eberhard. "Particle screening phenomena in an oblique multi-level tumbling reservoir: a numerical study using discrete element simulation", Granular Matter, 2007

Publication

---

**8** Submitted to Pennsylvania State System of Higher Education

Student Paper

---

**9** [www.tandfonline.com](http://www.tandfonline.com)

Internet Source

---

Exclude quotes Off

Exclude matches < 1%

Exclude bibliography Off

# Effect of Rushton Impeller Speed on Biogas Production in Anaerobic Digestion of Continuous Stirred Bioreactor

---

GRADEMARK REPORT

---

FINAL GRADE

**/0**

GENERAL COMMENTS

**Instructor**

---

PAGE 1

---

PAGE 2

---

PAGE 3

---

PAGE 4

---

PAGE 5

---

PAGE 6

---

PAGE 7

---

PAGE 8

---

PAGE 9

---

PAGE 10

---