

Ijaer

by Aulia Windyandari

Submission date: 30-Jan-2019 07:04AM (UTC+0700)

Submission ID: 1070310047

File name: ijaerv13n6_123.pdf (1.08M)

Word count: 3475

Character count: 17346

Comparative Analysis of B-Series, Au-Outline Gawn Series and Kaplan Series Propeller on Trimaran Ship using Computational Fluid Dynamics Method

Berlian Arswendo Adietya¹

¹Naval Architecture Department, Engineering Faculty, Diponegoro University, Semarang, Indonesia.

Hartono²

²Industrial Engineering Department, School of Vocation, Diponegoro University, Semarang, Indonesia.

Adry Zakki³

¹Naval Architecture Department, Engineering Faculty, Diponegoro University, Semarang, Indonesia.

Aulia Windyandari²

²Industrial Engineering Department, School of Vocation, Diponegoro University, Semarang, Indonesia.

Author for correspondence: Aulia Windyandari, ST. MT.,

Abstract

The propeller on a trimaran vessel requires some special criteria such as large thrust value, low-pressure value, and a smooth flow of propellers. This study has focused on the comparison of three types of propellers namely B-series, Au-Outline Gawn Series, and Kaplan series by considering some aspects of propeller diameter, number of blades, skew angle, and pitch. The numerical analysis was made by using Computational Fluid Dynamics (CFD) program to evaluate the performance of the propeller configurations. The result shows that Kaplan Series have the thrust value of 455628 N, the torque value of 96456.6 Nm, the pressure average value of 18608.92 Pa. According to the numerical results, it can be concluded that Kaplan series have a better performance compares with AU-Outline Gawn Series and B-Series for the Trimaran Ship.

Keywords: B-series propeller, AU Outline Gawn series propeller, Kaplan Series Propeller

INTRODUCTION

Indonesia is an archipelagic country which has a wide water area and potential as one of supporting economic growth. One of the most important means of transportation in supporting the economy in the field of transportation is the ship.

The Trimaran is a Multihull ship. Multihull ship is a type of ship that has a hull more than one hull, therefore, Trimaran means to have 3 pieces of the hull. Such a design can raise the Center of Gravity and the Center of Buoyancy so as to have high stability, [1]. In addition to the Center of Gravity and the Center of Buoyancy, speed is also greatly noted in multihull ship design. Therefore, the type of propeller that can produce a good ship speed but with a small vibration is preferred.

The types of propellers will be analyzed using the CFD method to find out whether the experimental test and the CFD are not much different and also know the most effective and efficient type of propeller in its use on a trimaran vessel.

The types of propellers used in the comparison are Au-Outline gawn series, B-Series, and Kaplan series. This comparison is aimed to determine the level of matching on ship KRI Klewang I.

Considering the subject matter of the background, several problem formulations can be taken as follows.

- Determination of the magnitude of the resulting thrust, on the propeller blade and the turbulent flow form of each trimaran ship propeller design
- Comparison of thrust, pressure and torque performance from B-Series propeller variations, Au-Outline Gawn Series, and Kaplan.
- Determination of the most effective type of propeller in its use on trimaran vessels with variations available.
- Based on the above background then the purpose of this study are:
- To know the value of thrust, streamline, and pressure that occurs on each type of trimaran ship propeller.
- To find out the comparison of the variation of B-Series propeller, Au-Outline Gawn Series, and Kaplan on a trimaran ship.
- To obtain optimum propeller type to improve trimaran ship efficiency

LITERATURE REVIEW

Trimaran Ship Propeller

In the development of the propeller undergoes some form of modification in order to get the most appropriate model as a ship propulsion tool. The most important requirement for a trimaran ship propeller is the high speed required but with a fairly small vibration since trimaran is usually used as a speedboat. Therefore, it is feared that cavitation causes vibration and performance reduction.

Propeller B-Series

Propeller B-Series or better known as Wageningen is a propeller that is often used primarily for ship merchant ship type. The shape of the B-Series propeller is very simple. This propeller has a modern section and good performance characteristics. Generally, B-Series propellers have variations [2]:

- H/D 0,5 - 1,4
- Z 2 - 7
- AE/Ao 0,3 - 1,05

Propeller Au-Outline

This Au-outline type propeller is the result of the development of "AU type Aerofill" by conducting testing with the systematic series test method. This type of propeller has a better performance than the previous type, both in terms of efficiency, cavitation, and vibration of the propeller. The diagram design of the experimental results of this series has been used for the planning of modern ship propellers.

Kaplan Propeller

Kaplan's propeller is a propeller using axial flow reaction. This type of Kaplan is arranged like a propeller on a boat. The propeller usually has 3 to 7 blades.

In a similar way to a power generator turbine, the Francine turbine, the Kaplan of which works by reaction principle. This Kaplan propeller has a road wheel similar to an airplane propeller.

Hydrodynamics of Propeller.

Hydrodynamics is an event where the velocity between the top and bottom of the hydrofoil occurs differently. The fluid passing through the top of Hydrofoil travels faster than the fluid passing through the bottom. This is due to the difference in pressure between the upper fluid flow and the lower fluid flow. As we know that the amount of pressure is inversely proportional to the magnitude of the speed.

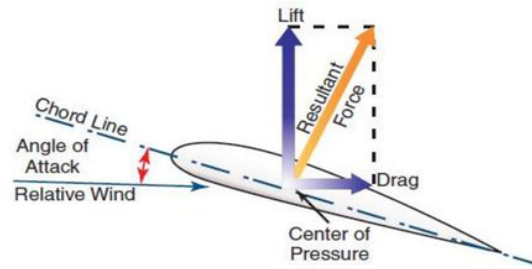

Figure 1. Forces of propeller foil

Geometry of Propeller

The surface of the rear-facing vane is called the side of the face, or face, (face) or high-pressure side, while the opposite side is called the back or the back side, or the low-pressure side, [3].

The simplest form of high side pressure is a helical surface. This surface can be defined as a surface formed by a straight line, called a generator or generator line (generatrix, or line generator) that revolves around an axis passing through one end and simultaneously moving along the axis. The axial distance traveled in each range is called the step or the spacing distance of P (pitch). If the screwing step is fixed then it means that P for all radius in the vane is thus the same, [4].

The Characteristics of Propeller

The propeller load characteristics can be presented with a graph of several coefficients in the form of sizes. In general, the characteristics of the ship's propeller under open water test conditions are represented in the KT diagram (Thrust coefficient) - KQ (Torque coefficient) - J (Advanced coefficient). The equation model of ship propeller performance is as follows:

$$KQ = \frac{Q}{\rho n^2 D^4} \quad (1)$$

$$J = \frac{Va}{nxD} \quad (2)$$

$$KT = \frac{T}{\rho n^2 D^4} \quad (3)$$

Where:

KT = Thrust coefficient

KQ = Torque coefficient

J = Advanced coefficient

Va = Advanced velocity

D = Diameter of propeller

n = Propeller revolution

- 10
 T = Thrust of propeller
 Q = Torque of propeller
 ρ = Density of fluids

For the value of propeller efficiency in open water is given the formula:

$$\eta_0 = \frac{TxVa}{2\pi\rho n x Q} \quad (4)$$

$$\eta_0 = \frac{JKT}{2\pi KQ} \quad (5)$$

Skew Angle Propeller

The propeller develops several modifications of the slash, the skew propeller, in which the shape of the propeller is somewhat tapered on its part, the skew angle propeller itself has the sense that the angle between propeller shaft center line to blade tip. The blade tip itself is the encounter of the trailing edge and leading edge on the surface propeller and is the maximum distance of the propeller radius. Skew on propeller can serve to reduce load and propeller pressure when fluid flows break, [5].

Skew on the propeller itself is divided into two types: biased skew (skew bias) and balanced skew (balanced slope).

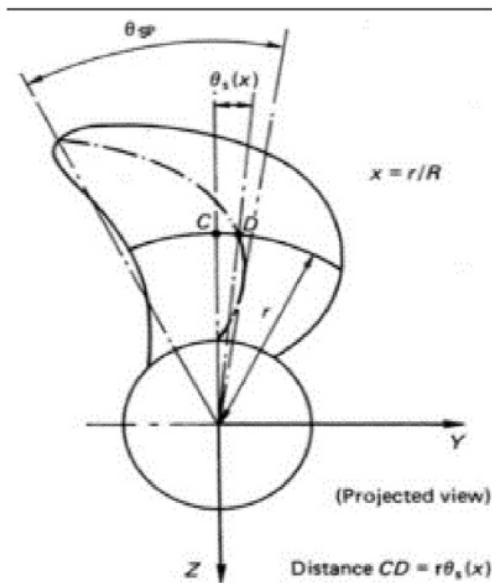

Figure 2. Skew Angle propeller

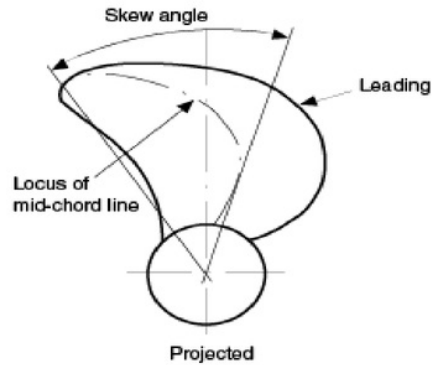

Figure 3. Balanced skew

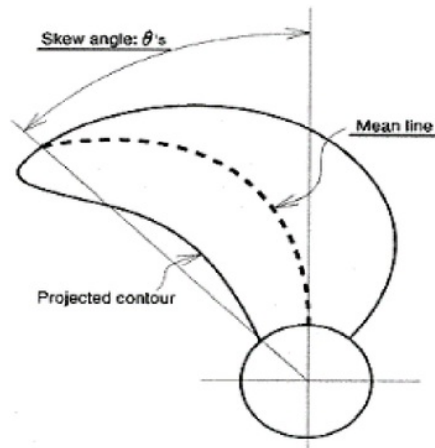

Figure 4. Biased skew

Blade Area Ratio

Blade Area Ratio or BAR is the ratio of the vane leaf area to the full blade tip rotation area or commonly referred to as A0. In reality, there are 3 BAR types, namely: Projected Area, Developed Area, and Expanded area

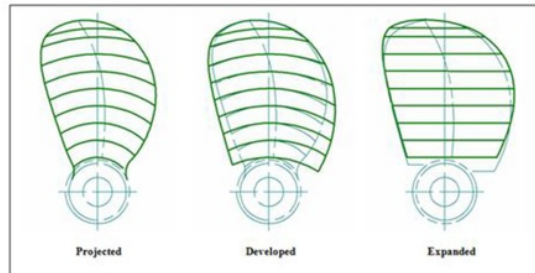

Figure 5. Type Blade Area Ratio.

To some extent the propeller area has the following equation:

$$A_0 = \frac{\pi D^2}{4} \quad (6)$$

$$\frac{A_p}{A_0} = \frac{4A_p}{\pi D^2}$$

$$\frac{A_D}{A_0} = \frac{4A_D}{\pi D^2}$$

$$\frac{A_E}{A_0} = \frac{4A_D}{\pi D^2} \quad (7)$$

Computational Fluid Dynamics (CFD)

Computational Fluid Dynamics (CFD), is one of the branches of fluid mechanics that uses numerical methods and algorithms to solve and analyze problems related to fluid flow.

The purpose of the CFD is to predict accurately the flow of fluids, heat transfer, and chemical reactions in complex systems, involving one or all of the above phenomena. This technique is very useful and can be applied in industrial and non-industrial fields. There are several advantages of CFD based on an experimental approach to fluid system design, among others:

- Minimize the cost and time of designing a product, if the design process is done with an experimental test with high accuracy.
- Has the ability of a study system that can control experiments that are difficult or impossible through experimentation.
- Have the ability to study systems under hazardous conditions at or beyond critical tipping points (including safety studies and accident scenarios).

In the design work, the existing problems need to be described into the CFD software by describing the model and also the determination of boundary conditions. Furthermore, in the solver, the problem will be calculated by Navier Stroke equation approach. From the calculation results than obtained the output of the running program CFD. Computational Fluid Dynamics consists of three main elements, [7]:

• Pre Processor

The pre-processor includes input from flow problems to a CFD program and the transformation of the input to a form suitable for use by the solver.

• Solver Manager

The solver can be divided into three types, namely finite difference, finite element, and spectral method.

• Post Processor

Post-processor is the stage of visualization of the previous stage. Postprocessors are growing with the advancement of engineering workstations that have great graphics and visualization capabilities.

PROPELLER MODELING

The main data size of the propeller is processed using propeller modeling software which is propeller coordinate processing software.

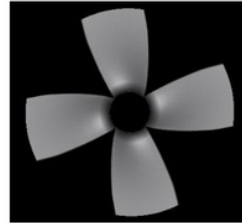

Figure 6. Propeller modeling Software

Primary size data propeller processed using propeller modeling software Furthermore, made a 3D model to be processed into solid objects before putting to the analysis, 3D modeling using the 3d solid work software.

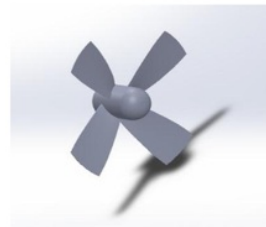

Figure 7. 3D Modeling Software

The next stage is the geometry where the model is checked whether the model is solid. Then the boundary is formed on the x-axis z plane and the definition of each boundary section such as inlet, outlet, and wall settings.

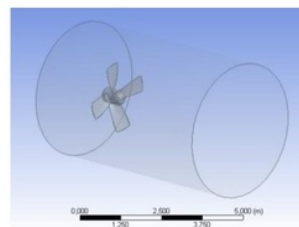

Figure 8. Geometry Stage

Next is the meshing stage to determine the size of each element and set the detail through the size of the elements we use.

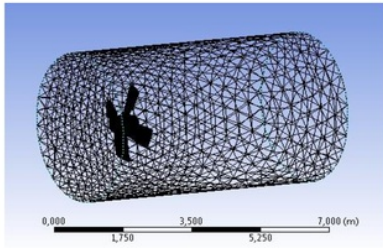

Figure 9. Mesh Stage

Next, we set each criterion we use by setting the Set-up. The set-up used is a criterion that has been in the previous validation so get results that have errors not far from the results of research that has been done. The following Domains Physics are used.

Table 1. Domain Default

Domain - Default Domain	
Type	Fluid
Location	B342
<i>Materials</i>	
Water	
Fluid Definition	Material Library
Morphology	Continuous Fluid
<i>Settings</i>	
Buoyancy Model	Non Buoyant
Domain Motion	Rotating
Angular Velocity	[rev min ⁻¹]
Axis Definition	Coordinate Axis
Rotation Axis	Coord 0.1
Reference Pressure	1.0000e+00 [atm]
Heat Transfer Model	Isothermal
Fluid Temperature	2.5000e+01 [C]
Turbulence Model	k epsilon
Turbulent Wall Functions	Scalable

Here is a picture of the set-up settings in the boundary that have been created in the previous stage.

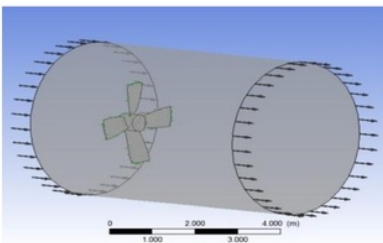

Figure 10. Boundary Set-up

The solution stage is the stage where the boundary that has been given the criterion is done an iteration to get the convergence result.

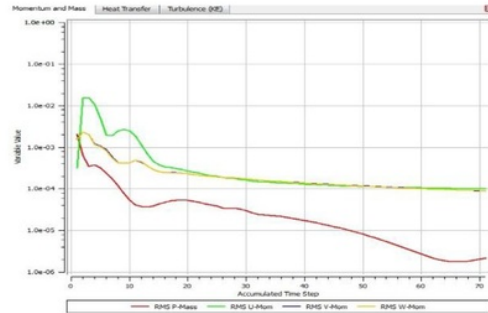

Figure 11. Convergence model

The final stage is the post-stage where we get the results that can be simulated either 3D or 2D.

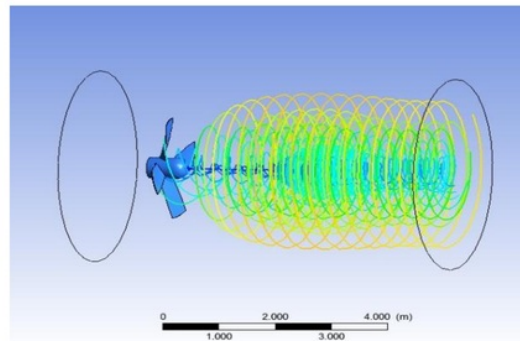

Figure 12. Result model

Table 2. Comparison of test results with CFD simulation

Rotation Speed (rpm)	Experiment (KT) (AU,B,Kaplan)	Result CFD (KT) (AU,B,Kaplan)	Results Error (%)
750	25,81	26,92	4,1 %
750	28,37	29,58	4,0 %
750	32,21	33,523	4,2 %
750	4,4908	4,6208	2,8 %
750	4,3508	4,4762	3,1 %
750	6,8981	7,0968	2,7 %

MODEL VALIDATION

Validation is used to determine the right boundary condition to analyze 3 propeller models. The model reference for validation is taken from the trimaran ship propeller testing, ie the propellers used type B-series, Au-outline, and Kaplan slope angle hub 0°, following the propeller data for validation:

- Propeller diameter: 2.21 m
- Number of blades: 4
- Pitch / diameter: 0.80
- Skew, Degree: 29,7°

In this study, rpm is taken close to rpm used in the journal. The results of calculations with CFDs on CFD based software are as follows:

RESULTS AND DISCUSSIONS

Comparisons of Thrust and Torque

From the analysis result, the highest thrust at 750 rpm is Kaplan Series propeller with the slope of propeller hub 0° with value 455628 N, whereas in B series 402139 N and Au-Outline 365929 N that is with the angle of slope propeller hub 0°.

From the analysis, the highest torque at 750 rpm is Kaplan Series propeller with the slope of the hub propeller 0° with the value of 96456,6 N, whereas in B series 60842.6 N and Au-Outline 62819.2N i.e. with the angle of the hub propeller 0° (Table 3) below:

Table 3. Thrust and Torque Propeller

MODEL	AU-OUTLINE	B-SERIES	KAPLAN
Thrust (N)	365929	402139	455628
Torque (N.m)	62819,2	60842,6	96456,6

From thrust analysis result, the comparison of thrust value between angle 0° with another model as shown in (Fig. 13) below:

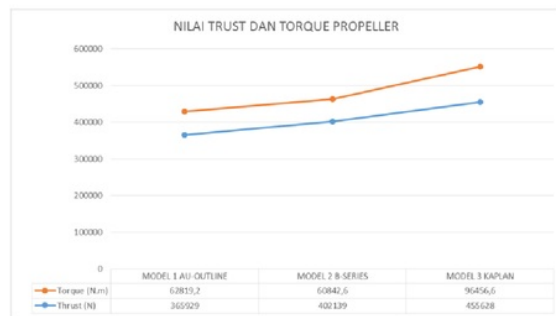

Figure 13. Thrust and Torque Comparison

Pressure comparison on model

Here are the coordinates of each point and line used to determine the pressure on the analysis.

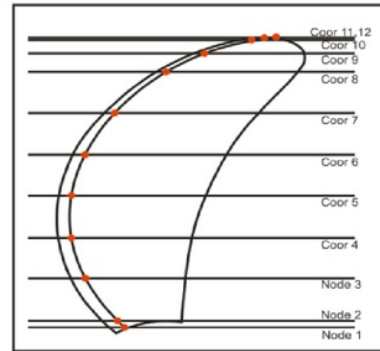

Figure 14. Pressure Coordinates

From the analysis of B-series propellers, Au-Outline and Kaplan with the slope of the 0° hub propeller having the highest pressure are 24597,875 Pa, the B-Seris propeller type and the lowest in Kaplan 13978.68 Pa As shown in the following graph:

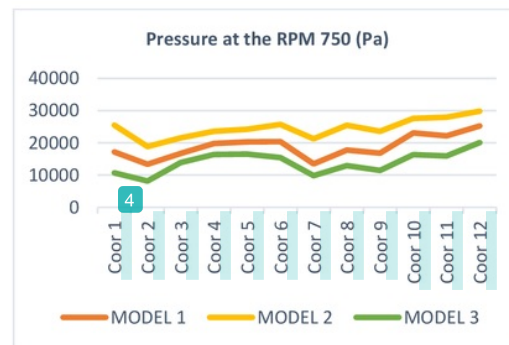

Figure 15. Pressure on Model.

In the contour simulation, Kaplan propellers obtained with a slope angle of 0° hub propeller have a low-pressure value and B-4 series has the highest pressure value.

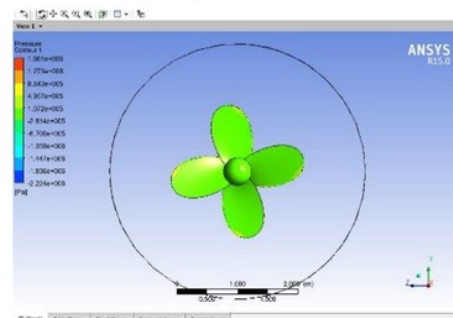

Figure 16. Contour of B-series

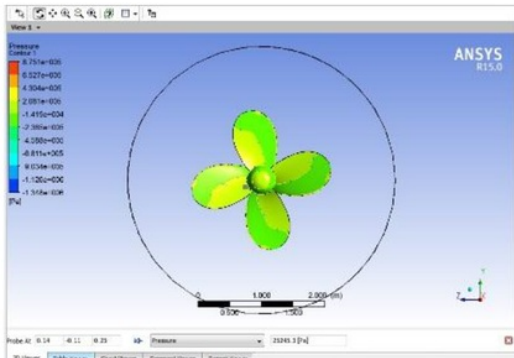

Figure 17. Contour of Au-outline

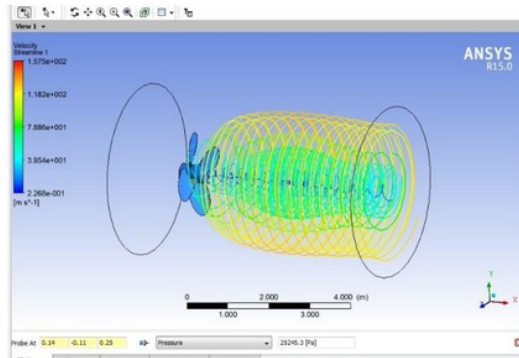

Figure 20. Velocity Coordinates

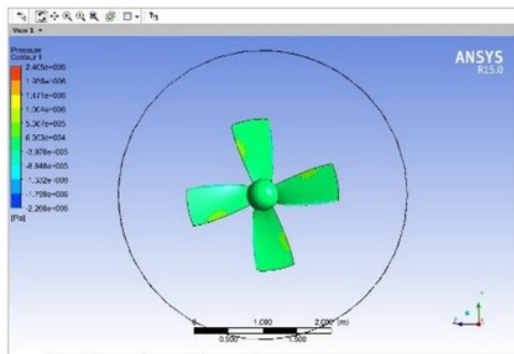

Figure 18. Contour of Kaplan

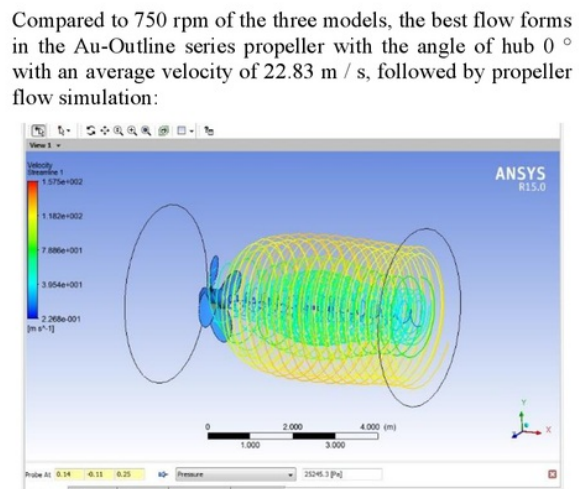

Figure 21. Fluid flows on Au-Outline at 750 RPM

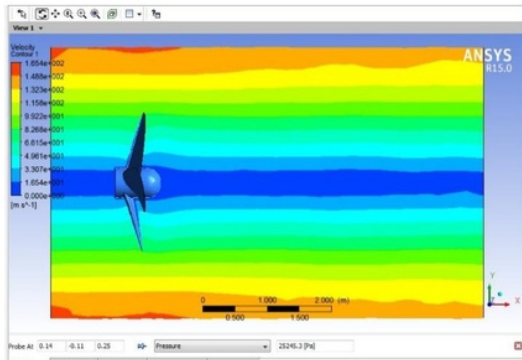

Figure 19. Pressure on the back side at 750RPM

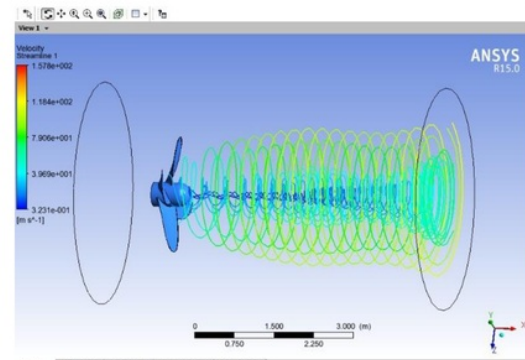

Figure 22. Fluid flows on B-series at 750 RPM

Turbulence Comparison at 450 RPM

Here are the coordinates to determine the average velocity during the analysis:

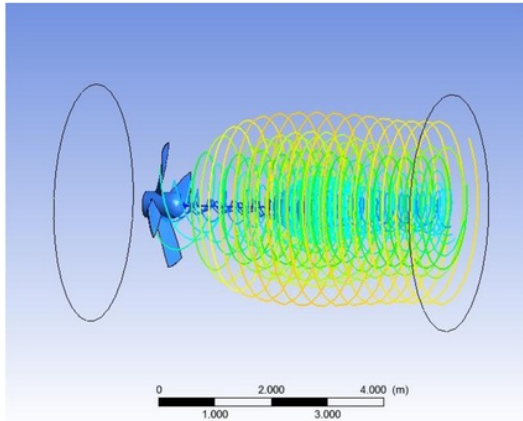

Figure 23. Fluid flows on Kaplan at 750 RPM

Seen from the picture of the turbulent flow, the Au-outline propeller flow has the fastest turbulence value. Below is a table showing the comparison of velocity values on the three propeller models.

Table 8. Magnitude of Velocity

VELOCITY 750 RPM				
MODEL 1 AU OUTLINE SERIES				
4	X	Y	Z	Velocity (m/s)
Coor 1	0,80	0,86	0,009	22,48
Coor 2	0,90	0,86	0,009	22,66
Coor 3	1,00	0,86	0,009	22,75
Coor 4	1,20	0,86	0,009	22,89
Coor 5	1,40	0,86	0,009	23,05
Coor 6	1,60	0,86	0,009	23,15
Jumlah				136,98
Rata-Rata				22,83

VELOCITY 750 RPM				
MODEL 2 B-SERIES				
	X	Y	Z	Velocity (m/s)
Coor 1	0,80	0,86	0,009	22,72
Coor 2	0,90	0,86	0,009	22,68
Coor 3	1,00	0,86	0,009	22,70
Coor 4	1,20	0,86	0,009	22,75
Coor 5	1,40	0,86	0,009	22,80
Coor 6	1,60	0,86	0,009	22,84
Jumlah				136,49
Rata-Rata				22,75

VELOCITY 750 RPM				
MODEL 3 KAPLAN SERIES				
11	X	Y	Z	Velocity (m/s)
Coor 1	0,80	0,86	0,009	21,80
Coor 2	0,90	0,86	0,009	22,23
Coor 3	1,00	0,86	0,009	22,59
Coor 4	1,20	0,86	0,009	22,96
Coor 5	1,40	0,86	0,009	23,19
Coor 6	1,60	0,86	0,009	23,37
Jumlah				136,14
Rata-Rata				22,69

Comparison of Propeller Efficiency.

Looking for the efficiency value of the propeller using the formula

Table 10. Propellers Efficiency

	AU-outline	B-series	Kaplan
Pressure (Pa)	18863,59	24597,87	13978,68
Thrust (N)	365929	402139	455628
Torque (N.m)	62819,2	60842,6	96456,6
V (m/s)	22,83	22,75	22,69
D (m)	2,21	2,21	2,21
n (RPM)	750	750	750
Va (knot)	18,6	18,6	18,6
J	0,011	0,011	0,011
KT	26,92	29,58	33,523
KQ	4,62	4,476	7,0968
η_0 (efisiensi)	26352,19	21432,9	67569,3

CONCLUSIONS

Based on experiments and simulations that have been done then it can be concluded as follows:

- 1) After analyzing the B-Series propeller model, Au-Outline and Kaplan series with the slope angle of the propeller hub with Rpm model that is 750 Rpm obtained the following results, the B-series model has thrust of 402139 N, the torque of 60842.6 Nm, pressure of 24597,875 Pa and velocity of 22.75 m / s. Analysis of the Au-Outline Series propeller model, with 750 Rpm, obtained the following results, the Au-Outline Series model has 365929 N thrust, the torque of 62819.2 Nm, the pressure of 18863.6 Pa and velocity of 22.83 m / s. Kaplan Series propeller model analysis, with 750 Rpm obtained the following results, the Kaplan Series model has a thrust of 455628 N, torque of 96456.6 N.m, the pressure of 13978.68 Pa and velocity of 22.69 m / s.
- 2) The ratio of each thrust, torque, pressure value, the largest at 750 RPM, with the slope of the 0 °

propeller hub is the type of series Kaplan propeller. This type of propeller Au-Outline is a type of propeller that has the best turbulence speed and flow at RPM 750 on a Trimaran ship.

- 3) The optimum propeller used on the KRI Klewang I vessel is Propeller B-series with the angle of the hub propeller 0° with 750 RPM with an efficiency value of 0.01183.

3

ACKNOWLEDGEMENT

The works is funded by Research and Community Service Institution Fund (DPA SUKPA LPPM-2017), Diponegoro University on the project of "the Development of FRP Glass Bottom Boat Trimaran Prototype to Support Underwater Tourism in Karimunjawa Islands", under the scheme of applied and development research - (Riset Pengembangan dan Penerapan) RPP program.

REFERENCES

- [1] Anonymous, 1993, "The New Shorter Oxford English Dictionary," Clarendon Press, UK. Vol. 2.
- [2] Joubert, P., 2004, "Some aspects of submarine design part 1. Hydrodynamics," Approved for Public Release Distribution Unlimited (20041130), DSTO-TR-1622. Fishermans Bend, VIC, Australia: DSTO Platforms Sciences Laboratory, Commonwealth of Australia.
- [3] Andersen, P., Kappel, J.J., Spangenberg, E., 2009, "Aspects of propeller developments for a submarine," First International Symposium on Marine Propulsors, smp'09, Norway.
- [4] Harvald, Sv, Aa, 1992, Resistance and Propulsion of Ships, Wiley Interscience, USA.
- [5] Carlton, J., 2007, Marine Propellers and Propulsion, 2nd Edition, Butterworth-Heinemann, USA.

ORIGINALITY REPORT

15%

SIMILARITY INDEX

11%

INTERNET SOURCES

7%

PUBLICATIONS

12%

STUDENT PAPERS

PRIMARY SOURCES

- 1 Submitted to Universidad Nacional de Colombia
Student Paper 6%
- 2 ejournal.undip.ac.id
Internet Source 2%
- 3 Submitted to Universitas Diponegoro
Student Paper 2%
- 4 Submitted to Lake Park High School
Student Paper 1%
- 5 hasanpurluhari.blogspot.com
Internet Source 1%
- 6 Berlian Arswendo Adietya, Aulia Windyandari, Ahmad Fauzan Zakki. "The Study on Stability and Seakeeping Characteristics of the Glass Bottom Boat Trimaran in Karimunjawa Island", IOP Conference Series: Earth and Environmental Science, 2018
Publication 1%
- 7 Ekeberg, √ñrjan. "Modeling of Interactions

Between Neural Networks and Musculoskeletal Systems", *Frontiers in Neuroscience*, 2000.

Publication

<1%

8

Yadav, Anil Singh, and J.L. Bhagoria. "Heat transfer and fluid flow analysis of solar air heater: A review of CFD approach", *Renewable and Sustainable Energy Reviews*, 2013.

Publication

<1%

9

Submitted to De Montfort University

Student Paper

<1%

10

Liu, Y B, Y M Su, L Ju, and S L Huang. "The steady performance prediction of propeller-rudder-bulb system based on potential iterative method", *IOP Conference Series Earth and Environmental Science*, 2012.

Publication

<1%

11

www.benhavenarchives.org

Internet Source

<1%

12

irjet.net

Internet Source

<1%

13

azojete.com.ng

Internet Source

<1%

14

Wencai Zhu, Hongtao Gao, Yuchao Song. "Numerical Investigation of Propeller Noise From Tip Vortex Cavitation", Volume 7B: *Ocean Engineering*, 2017

<1%

15 www.citizendia.org
Internet Source

<1%

16 ejournal-s1.undip.ac.id
Internet Source

<1%

Exclude quotes Off

Exclude matches Off

Exclude bibliography On