

# Measurement Design of Sensor Node for Landslide Disaster Early Warning System

Aghus Sofwan  
Department of Electrical Engineering  
Diponegoro University  
Semarang, Indonesia  
asofwan@elektro.undip.ac.id

Sumardi  
Department of Electrical Engineering  
Diponegoro University  
Semarang, Indonesia  
sumardi.undip@gmail.com

Muhammad Irsyad R  
Department of Electrical Engineering  
Diponegoro University  
Semarang, Indonesia  
irsyadreyn@gmail.com

Najib  
Department of Geological Engineering  
Diponegoro University  
Semarang, Indonesia  
najib@ft.undip.ac.id

**Abstract**—Landslide is one of the most frequent disaster happened in Indonesia. It can occur due to some major factors, e.g.; high rainfall and soil moisture. In order to predict the occurrence of landslide disaster, data sensing system of these factors are acquired. A prototype of data acquisition is proposed. The prototype provides sensors for sensing of four parameters, which are MPU 6050 sensor, tipping bucket with reed switch, two of FC-28 humidity sensors, and 801s sensor, to measure slope, rainfall, moisture, and ground vibration, respectively. This system is also equipped with the process of data retrieval or log data in real-time with SD Card in the process directly and delivery via the server via SIM900. From the sensor test results, which are obtained from reading value of each sensor, the system shows low error values of 0.165, 0, 0.39, and 0.71, for MPU6050, tipping bucket, 801S, and the two of FC-28 sensors, respectively.

**Keywords**— *Sensor node, landslide, early warning system*

## I. INTRODUCTION

Indonesia is a country with a high level of natural disasters. One of the most common disasters in Indonesia is a landslide, which is a movement sliding of the soil, rocks, and organic materials found in the cliffs caused by gravity and soil structure that can affect the movement of the soil [1]. Indonesian National Board for Disaster Management (BNPB) releases data disaster that there have been 3996 incidents of disasters covering natural disasters and non-natural disasters, in 2017 to 2018. In addition, 1116 landslides have occurred in Indonesia during that period [2][3].

Landslide occurs due to unstable slope conditions, so that the material / rocks above the slope move down. Slope instability can be caused by several factors; the main being is the saturation of the material by water (rain). Two main factors can influence the occurrence of landslide, which are natural and human activity factors. The natural factor that can trigger the occurrence of landslides are water content, seismic activity, and volcanic activity. The influence of these factors can vary depending on the slope factor of the cliff, the morphology of the soil, the type of soil, the geologic conditions of the soil, and the presence or absence of the building [4][5]. These causal and trigger factors are the basic parameters for analyzing a landslide event.

Landslide is a disaster that occurs suddenly so that raises many victims. The lack of a warning system resulted into the emergence of high casualties. Therefore, we need a landslide detection tool that can identify various parameters that causes landslide disaster in real time. Thus, it can be an early warning of landslides.

In previous research, an early warning system for landslide has been developed using data from satellite and geospatial condition database. In addition, there is research to analyze data obtained from satellites in the form of rainfall monitoring which then will produce a prediction of landslide [6][7][8]. In addition there are studies that connect landslide monitoring using smartphones via bluetooth[9].

In this research, we designed three pieces of sensor nodes, which are interconnected through wireless sensor network (WSN). The designed sensor network provides advantages in the measurement of data in the field and make the landslide warning system more effective. The main reasons of using WSN are the flexibility of delivery and real time remote communication.

The main contribution to this paper is providing a system design of the node, which measures physical parameters that cause landslide disaster. The sensor node performs measurement of four main parameters, namely the detection of rainfall, soil moisture content, slope, and vibration of the soil.

The rest of this paper is organized as follows. In the next section, system architecture of the designed system is described in detail. In Section III, the results of designed system and discussions are provided. And in the Section IV, conclusion is provided.

## II. HARDWARE DESIGN

### A. Microcontroller Circuit Sensor Node

In this section, we describe the architecture of the designed system in detail, as shown in Fig. 1. The system consists of three main parts, which are node, data communication, and server parts. The focus of this paper is in designing of a node for measurement of physical parameters, which are rainfall, humidity, slope, and ground vibration. The node uses sensors as follows. The MPU 6050

sensor is used as a tilt detector, the FC-28 sensor is used as a humidity sensor, tipping bucket with reed switches is employed to detect rainfall in the 801s instrument environment, and sensor as a ground vibration reader. Then the sensed data from the sensors will be stored in the data logger pad SD Card. We apply SIM900 GPRS-based to transmit data to the database, and will be displayed in web-based form. The figure of the deployed node is shown in Fig. 1.

Fig. 3 exposes the design of microcontroller circuit sensor node. The designed node consists of Arduino Mega2560 microcontroller, power supply from solar panel, MPU6050 sensor, soil moisture sensor, tipping bucket rain sensor, XL4005 regulator, and SIM900A module.

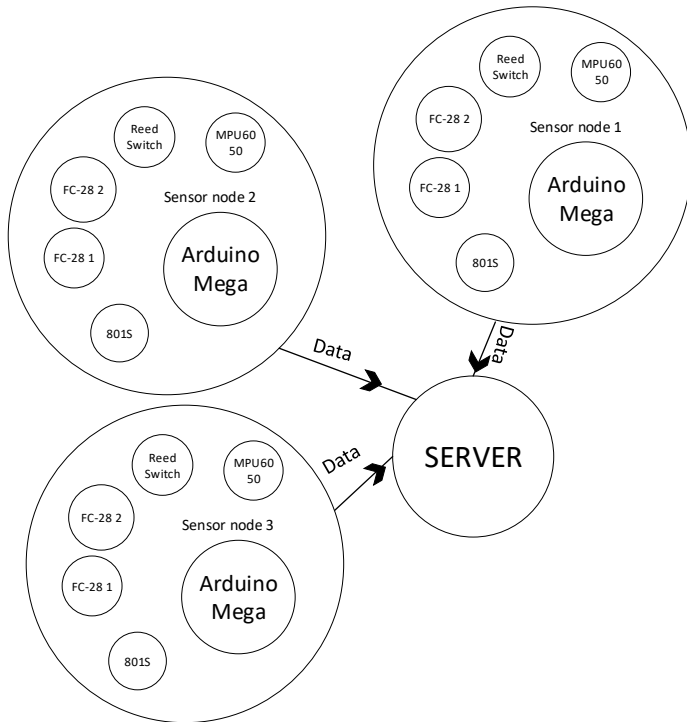

Fig. 1. Overall WSN architecture of design system, which consists of three Sensors Node to Server



Fig. 2. Node for landslide detector

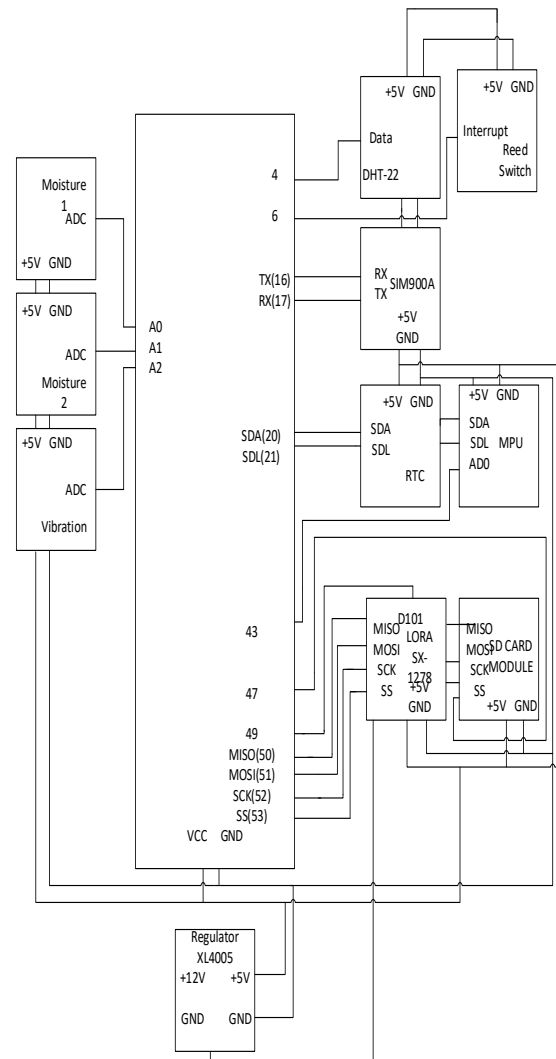

Fig. 3. Microcontroller Circuit Sensor Node

The functions of the components are described as follows. The Arduino Mega has a role as a central control and data processing on this sensor node. It can be programmed with Arduino IDE. The MPU6050 sensor serves to measure slope change utilizing I2C communication (SCL & SDA). The sensors connect to the microcontroller use pin 20 (SDA), 21 (SCL) and 43 (AD0) to adjust the MPU address. The soil moisture serves to measure the moisture content in the soil. The output of this sensor in the form of calibrated analog, with the unit in value of percentage. Tipping bucket rainfall sensor serves to measure rainfall using external interrupt function on microcontroller. The interrupt pin used is pin 5. The DHT-22 sensor serves as a detector of humidity and temperature in the system. This sensor is used to prevent overheating. Pin used is a digital pin 4. Sensor Vibration 801S using analog A3 pin to measure the magnitude of ground vibration. SIM900A module is GSM module function to send sensor data to website using serial communication. The Arduino Mega has three serial communication facilities. The GSM module is connected to serial2, The RX pin module is connected to pin 17 (TX) microcontroller and pin TX module is connected with pin 16 (RX) microcontroller. The LORA SX-1278 module is a radio communication module that uses 410-510 MHz frequencies

with remote range capabilities using SPI communications on pin 50 (MISO), 51 (MOSI), 52 (SCK), and SS (53). An SD card module serves as a storage and read data logger from the system. This module uses SPI communication at 50 (MISO), 51 (MOSI), 52 (SCK), and SS (47). RTC (Real Time Clock) module The DS-1307 is a module that functions as an electronic clock that calculates system time and keeps the time in real time. power supply comes from solar panels is connected to the battery and the solar power controller.

### B. Power Supply Circuits Design

The design of power supply circuit, as shown in Fig. 4, consists of solar panels, solar power controller, dry battery, and XL4005 voltage regulator. The solar panels serve as the main energy source with a capacity of 20 wp. The solar panel output voltage ranges between 12-20V, which is connected to the solar power controller. Solar power controller has three connections. The first connection of a solar panel receives power from a solar panel. The second connection is connected to a 12.7V 7.2AH dry battery. And the last connection is linked to the load, which is a sensor node system that requires a working voltage of 5V. While the solar power controller has an output of about 12V. So, it needs voltage deminers with XL4005 regulator that has the ability in the range 4V-38V. The use of a battery with a voltage of 12.8 V can be used for 2 days non-stop in the absence of a power supply source. For field testing, it has been tested for 1 month non-stop with the equipment running continuously.

### C. Software Design

The design of software in the design system applies Arduino IDE software. Fig. 5 exposes the flowchart of software design.

The design of the tool starts with the creation of software on the Arduino IDE as a container for loading the programs needed in this tool. The initiation was carried out by entering the library of each component consisting of sensors 801S, DHT-22, 2 FC-28, MPU6050, and reed switches. For communication of module components initiated by Lora SX1278, and SIM900. Other components consist of RTC, relay and Fan. After initiation on void (Setup), the command is repeated repeatedly on Arduino in void (loop). Where at the time of loading this sensor reading is then changed in the form of the parameters of each sensor. After that it was done to find out the sensor values for landslide security parameters through ANN. Then the device will send an alarm to the receiver. At each reading the storage of the server and SD Card is carried out.

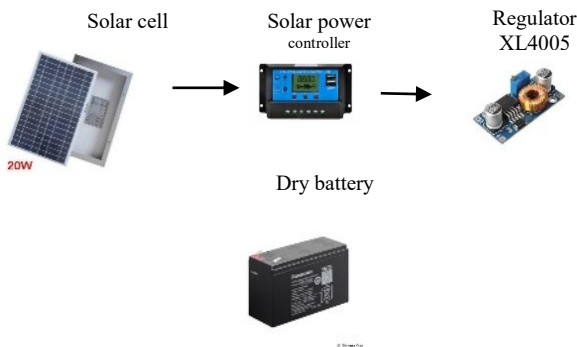

Fig. 4. Power Supply Circuits

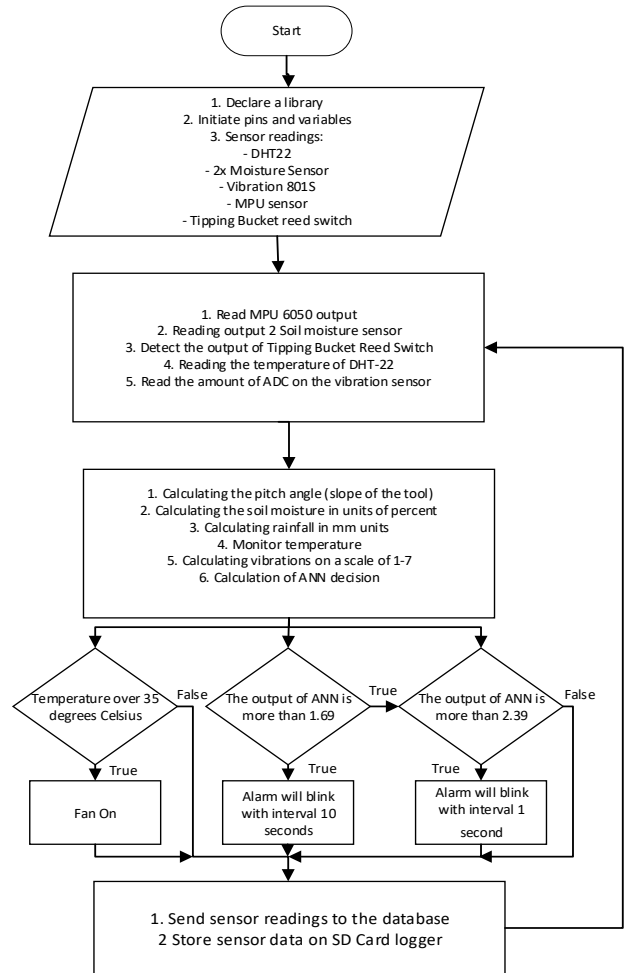

Fig. 5. Flowchart of software design

## III. RESULT AND ANALYSIS

In this section, we exhibit several performed testing of parts of the designed system, which are tilt parameter test, groundwater level, rainfall parameters, vibration sensors, GSM SIM900 module, and LORA SX 1278.

### A. Tilt Parameter Test

Testing slope angle has a range of 0-45 degree. This is in accordance with the slope requirements in which the units used are percent. The 100% value in the slope represents a 45o angle. In this test the variation of data collection from angle 0%, 20%, 60%, 80%, and 100%. The measuring tool used as the reference value is the android app "inclinometer" which can measure the slope in percentage value. Data retrieval is taken for 10 minutes and for 5 minutes retrieve data to be included in reporting, due to slow MPU response. Data retrieval has a delay of 10 seconds.

Table I exhibits the average error of each test at a predetermined time. The mean error rates on the slope variations 0%, 25%, 50%, 75%, and 100% are 0.17, 0.33, 0.07, 0.49, and 0.70, respectively. The highest average error rate is found in the 100% slope testing and the lowest average error rate is on the 50% slope test. For testing this sensor has an error value of 0.165833. Errors occur because of the lack of responsiveness of the device in data readings and less precision reading conditions. But , the error still within tolerance range under 1%.

TABLE I. SLOPE TEST RESULTS

No	Angle Reference (degree)	Object angle (%)	Error (%)
1	0	0.192	0.192
2	20	19.990	0.001
3	40	39.980	0.002
4	60	59.800	0.200
5	80	80.230	0.230
6	100	99.630	0.370

*B. Testing of Parameters of Groundwater Levels*

Testing of soil moisture sensor output value is done by using 2 FC-28 sensor with variation value from 0% - 90%. Data retrieval is taken for five minutes length. The result of data taken are shown in Table II and Table III.

Table II shows the average error of the humidity sensor 1 of each test based on the calibration tool and the quantity of water. The average error rate on soil moisture variation value of 0%, 10%, 20%, 30%, 40%, 50%, 60%, 70%, 80%, and 90% respectively are 0.648, 0.1787, 0.244, 0.204, 0.036, 0.444, 0.387, 0.214, 0.195, and 1.432. The greatest error value is seen in soil moisture 90% of 1,432 and the smallest average at 40% .of 0.026. The greatest error in sensor 1 can occur at 90 percent due to the inability of the tool in reading when the water to soil ratio is above 80%, and when the movement occurs on the sensor the value shows movement .

Table III exposes the average error of the second humidity sensor. It can be seen that the average error rate on soil moisture with variation value of 0%, 10%, 20%, 30%, 40%, 50%, 60%, 70 & 80% and 90%, respectively 0.657, 0.5765, 0.56, 0.522, 1.368, 1.053, 0.681, 0.1222, 0.414, and 1.152. The greatest error value occurs in soil moisture 40% with value of 1,368 and the smallest average at 70% with value of 0.1222. The greatest error in sensor 2 with a 40% reference number can occur due to inaccuracy of the sensor readings on the device caused by the factor of reading the data value.

TABLE II. SOIL HUMIDITY SENSOR TEST RESULTS

No	Soil Mass	M.Soil+ M.Water	Percent age	Calibra tion	% Sensor	Error
1	150	150	0%	0%	0.648	0.648
2	150	165	10%	10%	9.831	0.179
3	150	180	20%	20%	19.766	0.244
4	150	195	30%	30%	29.796	0.204
5	150	210	40%	40%	40.026	0.026
6	150	225	50%	50%	49.556	0.444
7	150	240	60%	60%	59.663	0.387
8	150	255	70%	70%	70.214	0.214
9	150	270	80%	80%	80.195	0.195
10	150	285	90%	90%	88.568	1.432
					Mean error	0.390

TABLE III. SOIL HUMIDITY SENSOR TEST RESULTS

No	Soil Mass	M.Soil+ M.Water	Percent age	Calibra tion	% Sensor	Error
1	150	150	0%	0%	0.657	0.657
2	150	165	10%	10%	9.434	0.576
3	150	180	20%	20%	19.446	0.560
4	150	195	30%	30%	29.478	0.522
5	150	210	40%	40%	41.368	1.368
6	150	225	50%	50%	48.947	1,053
7	150	240	60%	60%	59.319	0.681
8	150	255	70%	70%	68.880	0.1222
9	150	270	80%	80%	80.414	0.414
10	150	285	90%	90%	88.948	1.152
					Mean error	0.710

*C. Testing of Rainfall Parameters*

The testing of tipping bucket rainfall sensor is conducted by inserting some water volume variations into the sensor container. In this case, variations were performed 8 times from volume 15 ml up to 120 ml with addition of 15 ml each experiment. From Table IV and Table V, it can be seen that the number of ticks on the sensor is in accordance with the theory and observation. So that the error reading is equal to zero. For the calculation of the amount of water equal to the results read. The error value reading is zero. This sensor works properly.

*D. Testing of Vibration Sensors*

Testing of 801S vibration sensor with 10 bits analog base is compared with variation of vibration compared with tool calibration through android application "Vibrometer". Variations performed begin with a scale of 0 to 7. Vibration simulation is carried out by vibration and application using "Vibrinometer", which is normalized with an analog sensor value of 801S.

TABLE IV. TICKING BUCKET TEST RESULTS

No.	Water Volume (ml)	Tick Count (theory)	Tick Count (Observation)	Error
1	60	4	4	0
2	120	8	8	0
3	150	10	10	0
4	225	15	15	0

TABLE V. TEST RESULT OF TIPPING BUCKET AMOUNT

No.	Legible (ml)	Calculation (ml)	Error (ml)
1	60	60	0
2	120	120	0
3	150	150	0
4	225	225	0

### E. Testing of Vibration Sensors

Testing of 801S vibration sensor with 10 bits analog base is compared with variation of vibration compared with tool calibration through android application "Vibrometer". Variations performed begin with a scale of 0 to 7. Vibration simulation is carried out by vibration and application using "Vibrinometer", which is normalized with an analog sensor value of 801S.

Table VI shows that the vibrational magnitude of the sensor is in accordance with the theory and the calibration tool so that the error reading is equal to zero. This sensor 801S works properly because every scale is normalized.

### F. GSM SIM900 Testing

The testing of SIM900 of node sensor device is performed by sending data through Telkomsel Indonesia cellular network. Data transmission uses Arduino IDE program via serial TX RX. Fig. 6 shows the corresponding result where the data was successfully received on the server.

### G. Testing of LORA SX1278

The Lora SX1278 test is performed on the receiving and sending devices. The receiver is performed on the device node while the receiver is in the alarm indicator. The radio frequency used is 433 MHz. Data view of the sender and receiver are shown in Figs. 7 and 8.

TABLE VI. VIBRATION SENSOR 801S TEST RESULTS

No.	Vibration (Scale)	Calibration	Vibration Scale	Error
1	1	1	1	0
2	2	2	2	0
3	3	3	3	0
4	4	4	4	0
5	5	5	5	0
6	6	6	6	0
7	7	7	7	0

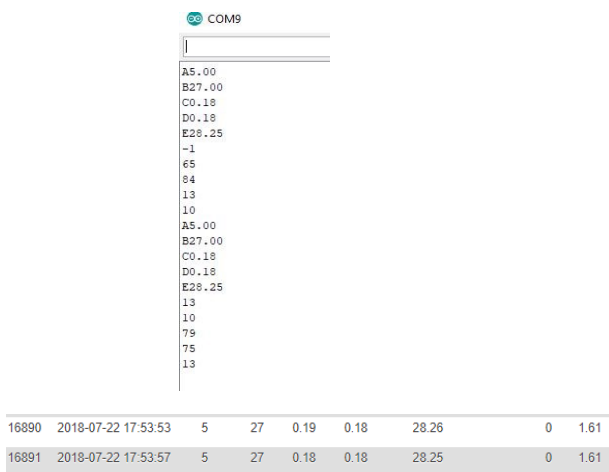

Fig. 6. Test results of data transmission via SIM900

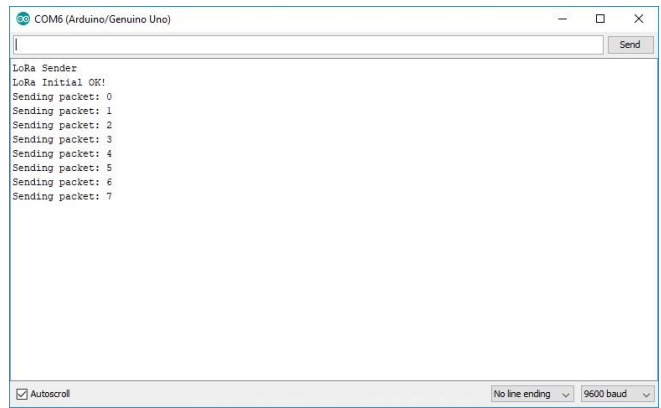

Fig. 7. Lora SX1278 test result on the sending device

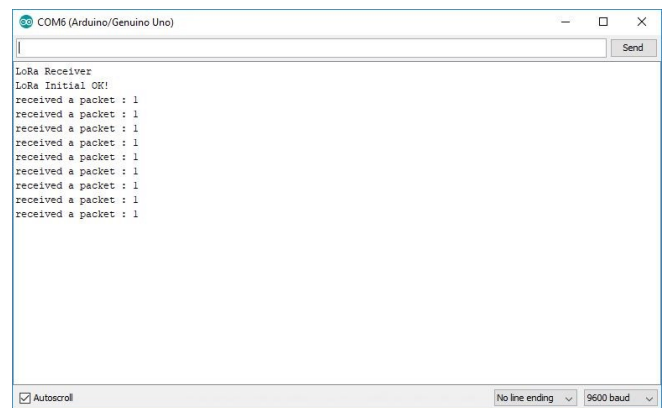

Fig. 8. Lora SX1278 test result on the receiver device

On Lora SX1278 test receiver and device successfully send and receive data. For testing on the sender, the tool sends the "1" command to activate the alarm.

## IV. CONCLUSION

The three sensor nodes on the wireless sensor network for 4 parameters causing landslides have been designed according to specifications. For testing in this study only tested on 1 tool and the other two tools have been verified the results in accordance with the reference In the parameters parameters of slope with MPU6050 sensor at the pitch orientation angle obtained error average when testing slope 0%, 20%, 40% 60%, 80%, and 100% are 0.192, 0.001, 0.002, 0.2, 0.23 and 0.37 respectively. For the overall error value on the MPU6050 test of 0.165. 3. In testing the parameters of moisture content in soil with soil moisture sensor obtained the results of humidity sensor 1 has the highest average error at 90% soil moisture percentage with an average error of 1432 and the smallest percentage of soil moisture 40% with average error of 0.026. At the humidity sensor 2 has the largest average error at 90% of soil moisture percentage with an average error of 1,152 and the smallest at 70% with the largest mean error of 0.122. For an average error average 1 humidity sensor has a value of 0.39 and a humidity sensor of 0.710. To test the rainfall parameters using rain sensor tipping bucket obtained error value equal to 0. For communication SIM900 has managed to send data from sensor node to server with delay time 4 second. Then Lora SX1278 has successfully sent alarm indication from sensor node to receiver tool.

## ACKNOWLEDGMENT

This work was supported by Superior Research of Higher Education (*PUPT*) – Diponegoro University grant in the fiscal year 2018

## REFERENCES

- [1] J. Cepeda, H. Smebye, B. Vangelsten, F. Nadim, and D. Muslim, "Landslide risk in Indonesia," October, p. 20, 2010.
- [2] BNPB, "Data dan Informasi Bencana Indonesia - BNPB."
- [3] S. Anwar, "Land Degradation and Desertification Assessment in Indonesia," vol. 23 December, 2011.
- [4] C. Margottini, P. Canuti, and K. Sassa, *Landslide Science and Practice*, vol. 6. 2013.
- [5] P. Highland, L.M., and Bobrowsky, *The Landslide Handbook — A Guide to Understanding Landslides*. Reston, Virginia, U.S.: Geological Survey Circular, 2008.
- [6] A. Sofwan, Sumardi, M. Ridho, A. Goni, and Najib, "Wireless sensor network design for landslide warning system in IoT architecture," *2017 4th Int. Conf. Inf. Technol. Comput. Electr. Eng.*, pp. 280–283, 2017.
- [7] M. V. Ramesh, "Real-time wireless sensor network for landslide detection," *Proc. - 2009 3rd Int. Conf. Sens. Technol. Appl. SENSORCOMM 2009*, pp. 405–409, 2009.
- [8] G. Qiao, P. Lu, M. Scaioni, S. Xu, X. Tong, T. Feng, H. Wu, W. Chen, Y. Tian, W. Wang, and R. Li, "Landslide investigation with remote sensing and sensor network: From susceptibility mapping and scaled-down simulation towards in situ sensor network design," *Remote Sens.*, vol. 5, no. 9, pp. 4319–4346, 2013.
- [9] M. El Moulat, O. Debauche, S. Mahmoudi, L. A. Brahim, P. Manneback, and F. Lebeau, "Monitoring System Using Internet of Things for Potential Landslides," *Procedia Comput. Sci.*, vol. 134, pp. 26–34, 2018.