

# SEDIMENTATION EFFECTS IN RESERVOIR TOWARD THE DECLINING FUNCTION OF FLOOD CONTROL

Pranoto Samto Atmojo<sup>1\*</sup>, Kirno<sup>2</sup>, Bertha Silvia Pratiwi<sup>3</sup>

<sup>1</sup>Civil Engineering Department Diponegoro University

<sup>2</sup>Balai Sungai Surakarta

<sup>3</sup>Engineering Faculty Darul Ulum Islamic Center University (Undaris)

[\\*pranotosa2001@yahoo.com](mailto:*pranotosa2001@yahoo.com) ; Phone: +62-8164246190

## Abstract

One of the reservoir function is as a flood control, with the principle of flood damming. The reservoir ability to reduce flood depends on the amount of its storage capacity. A river flowing into reservoir velocity will decrease, then consequently the sediment that is carried over by the river will settle. The reduction of the reservoir capacity due to sedimentation will decrease the reservoir capability as a flood control, because the ability to reduce the flood also declines. This research will analyze the magnitude of sediment effect in the reservoir toward the decrease of reservoir function as a flood control. The case study will use data from Wonogiri Dam.

Analysis includes comparison magnitude of spill out flood hydrograph on initial condition before the sedimentation, and later condition after sedimentation in reservoir, that is, by comparing the analysis of flood routing hydrograph. The result of data analysis, showed sedimentation that has occurred since 1980 to 2005 around 41.10% settled in the dead storage, 13.40% in the operational space, and 0.90% in the flood control space. The analysis result showed that the capability to reduce the reservoir's peak flood due to sedimentation decreases 570 m<sup>3</sup>/sec, in which originally the reservoir was able to reduce the flood as much as 2575 m<sup>3</sup>/sec on initial condition, and the reduction capability decreases to only about 2005 m<sup>3</sup>/sec after sedimentation. I hope the results of this analysis could be used as a reference reservoir management and in particular the management of sediment in the reservoir.

**Keywords :** flood control, reduce the flood, reservoir, sedimentation

## INTRODUCTION

### General Background

Flood is a natural phenomenon which is harmful and even worse it can threaten the life of the people. One of the ways to control or avoid the flood is by making a dam (Gosschalk, 2002). The dam with its storage (reservoir) can reduce the water discharge of the flood, in its peak, which the size of the reduction depends on the size of storage volume and elevation and also its spillway capacity. The river which is dammed would have the lower velocity of its water which makes the sediment carried off the water flow, thus it will settle as a sedimentation in reservoir and reduce its storage's volume. The reduction of the volume in the storage, caused by sedimentation, can decrease the reservoir's ability in reducing the flood. This case study or research takes place on

Wonogiri Reservoir, which began impounding on December 1980. The reduction of Wonogiri reservoir's capacity as a consequence of sedimentation was about 2.70% per year, and based on the survey in 2005 its sediment settled at Dead Storage 41.10% at operational location 13.40% , and at flood control 0.90% (JICA, Nippon Koei Co., Ltd, 2007).

This research analyzes the reduction level of the reservoir capacity and the magnitude of the reduction function of the flood control as a consequence of sedimentation.

The level of flood control reduction on the reservoir caused by sedimentation needs to be observed as a consideration to keep back its function or manage the sediment in reservoir for the further rescuing.

## Literature Study

### Correlation of Water Surface Elevation and Storage Volume

The correlation between the Water Surface Elevation and Storage Volume is a graph which explains the relation between the Elevation and the Storage Volume. With this graph it would be easier to know the particular elevation and how much the volume in the reservoir. If there is any change of water surface elevation, the change of its volume would also be known. Using this graph, the reduction of the storage capacity could be known if there is any sedimentation occurs in such volume. This graph will be used in the analysis the water discharge through the spillway. If the data are not available yet, the widespread of inundation in every meter of elevation is measured by a theodolite measuring instrument in the ground or with planimeter on the map. Whereas the sediment volume can be measured by echo sounding using grid system to facilitate the representation and computation.

The calculation of the relation between elevation and the reservoir volume can be conducted using Modified Prism Method (Vanoni, 1975) with the formula:

$$V = (E/3) x ( A + \sqrt{A \cdot B} + B ) \dots\dots\dots (1)$$

Where :

- V = storage volume (m<sup>3</sup>)
- A = contour width A (m<sup>2</sup>)
- B = contour width B (m<sup>2</sup>)
- E = difference of elevation between contour A and B (m)

The formula above can be illustrated as in figure 1 :

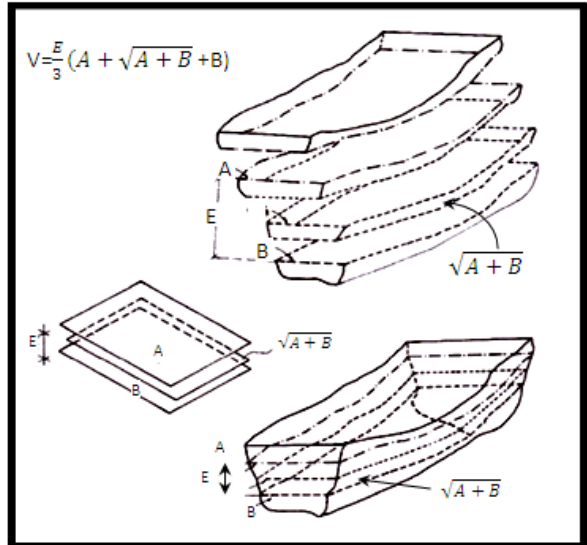

Figure 1. *Modified Prism Method* (Vanoni, 1975)

Then the graph relation between the elevation and the volume is made.

### Flood Routing

The base of the calculation uses the continuity principle and storage equation (Chadwick and Morffet, 1994):

$$I - O = \frac{ds}{dt} \dots \dots \dots (2)$$

Where :

I : *inflow* ; O : *out flow*, and  $\frac{ds}{dt}$  : the change of storage toward the time

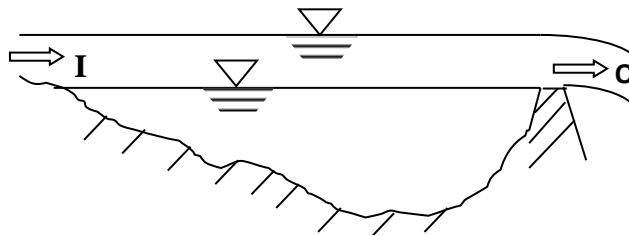

Figure 2. Long section of storage

The averaged of O values between  $t = t_0$  and  $t = t_1$  can be determined from the Unit Hydrograph curve. Out flow (O), which discharge over flow spillway, is calculated by  $O = m b H_d^{3/2}$ , or  $O = m A \sqrt{2gH_d}$  for the discharge passing under the gate. Therefore , the equation (2) can be changed into:

$$\frac{I_1 + I_2}{2} - \frac{O_1 + O_2}{2} = \frac{S_2 - S_1}{\Delta t} \dots \dots \dots (3)$$

The elements known are collected:

$$\frac{S_2}{\Delta t} + \frac{O_2}{2} = \frac{S_1}{\Delta t} - \frac{O_1}{2} + \left(\frac{I_1+I_2}{2}\right) \dots\dots\dots (4)$$

$$\frac{S_2}{\Delta t} + \frac{O_2}{2} = \frac{S_1}{\Delta t} + \frac{O_1}{2} - O_1 + \left(\frac{I_1+I_2}{2}\right) \dots\dots\dots (5)$$

$$N_1 = \frac{S_1}{\Delta t} + \frac{O_1}{2}$$

$$N_2 = \frac{S_2}{\Delta t} + \frac{O_2}{2}$$

The equation (5), can be simplified into :

$$N_2 = N_1 + \bar{I} - O_1 \dots\dots\dots (6)$$

$$\Delta N = \bar{I} - O_1$$

After the relation of N and O is obtained , the hydrograph flood routing can be calculated.

**Methodology of Study**

This research is a case study about the comparison analysis of flood routing before and after the sedimentation in the reservoir. The sequence of conducting this research begins from collecting the Study report, which has been conducted and related, literature study, collecting data and so on until the analysis of the reduction function of flood control, as in the flow chart on Figure.3.

**Data**

The data are taken from JICA, Nippon Koei Co., Ltd, 2007. The sediment distribution that occurs and hydraulic dimension spillway are as in Figure 4. The sedimentation which settles is measured based on DEM on 1980, 1993, 2005. The sediment distribution spreading in dead storage is 41.10%, in the operational space is 13.40% and in the flood controlling space is 0.90%. The sedimentation volume under the elevation is +138,30 m which is 16% from the total volume. The peak of the elevation spillway is +131.00 m, and the width of the *spillway* is 4x7.50 m, as in Figure 5. The flood hydrograph taken for the analysis is only on the large discharge duration, which is for 32 hours. The flood hydrograph on the river before there is a reservoir, is as in Table 1 and Figure 6. The relation of the elevation and the reservoir volume in 1980, 1993, 2005 (after it was built and there had been a sediment) is as in Figure 7. Based on the analysis, the reduction of the reservoir capacity caused by sedimentation in 1980-2005 is quite real, that is on the elevation of +132 and +133 m respectively, is 20 and 15 million m<sup>3</sup> (look at Figure 7, Table 2 and Table 4 in column 4).

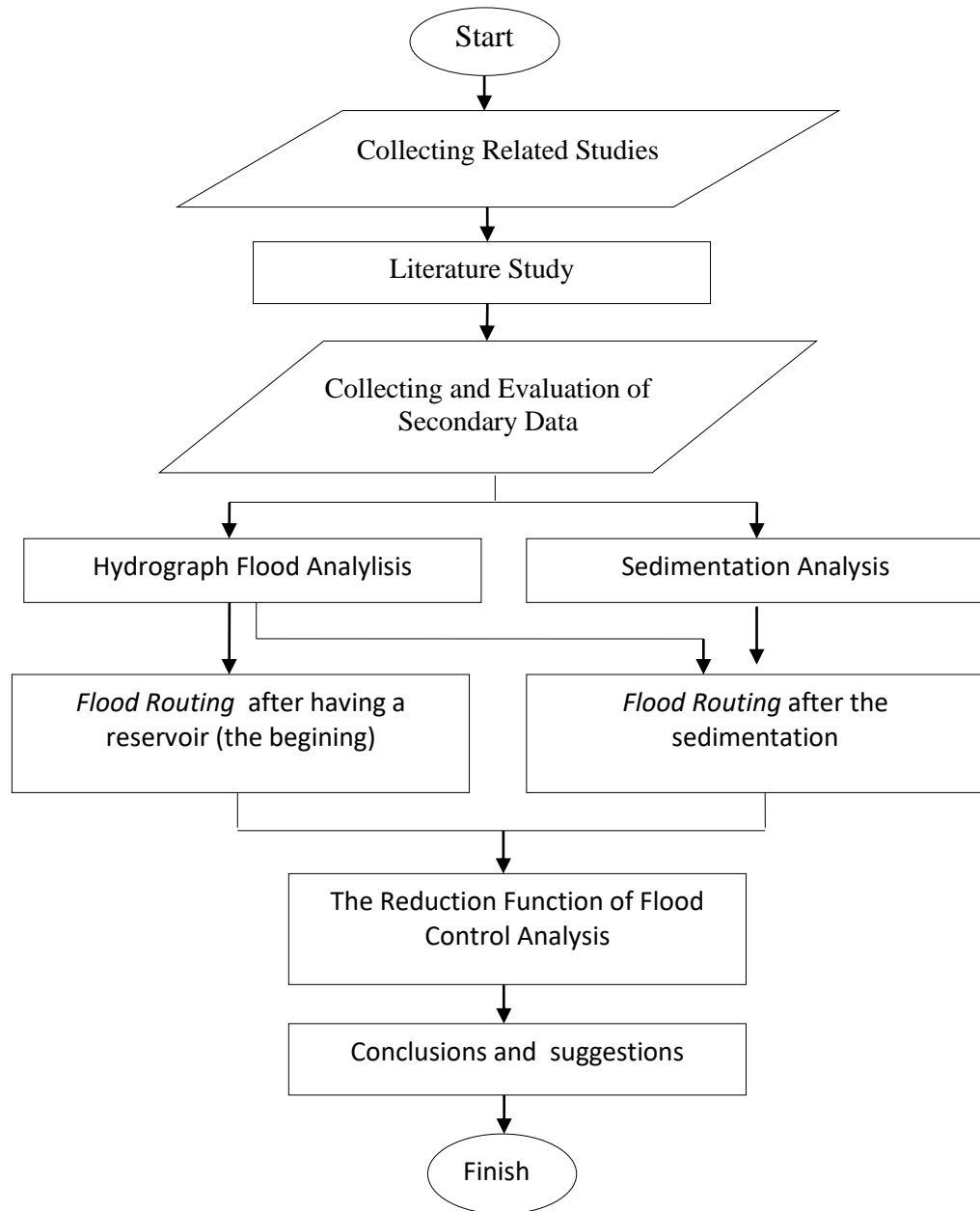

Figure.3 The Research Flow Chart

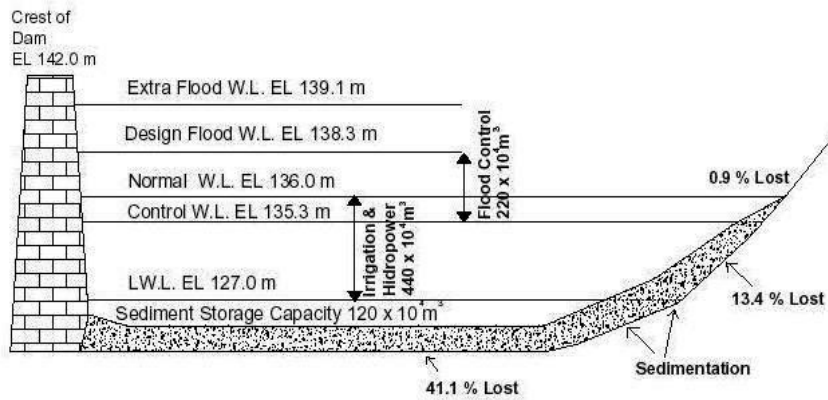

Figure .4 Volume and Storage of sedimentation Allocation (JICA, Nippon Koei Co.,Ltd, 2007)

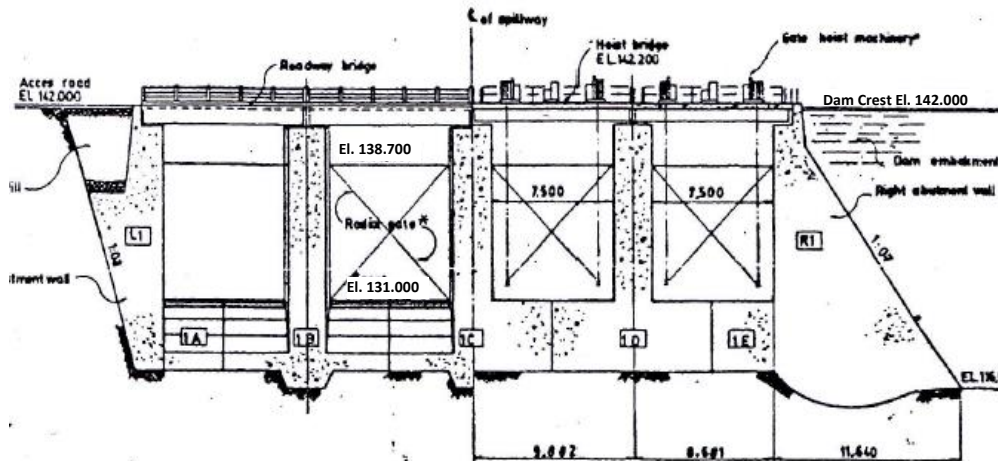

Figure.5 Spillway (Nippon Koei Co.,Ltd, 2009)

Table 1. Discharge and Time Relation

Time order (hour)	Q (m <sup>3</sup> /sec)	Time order (hour)	Q (m <sup>3</sup> /sec)
0	350	14	2800
2	450	16	2100
4	1000	18	1600
6	1800	22	800
7	2200	24	600
8	2550	32	400
11,8	4000		

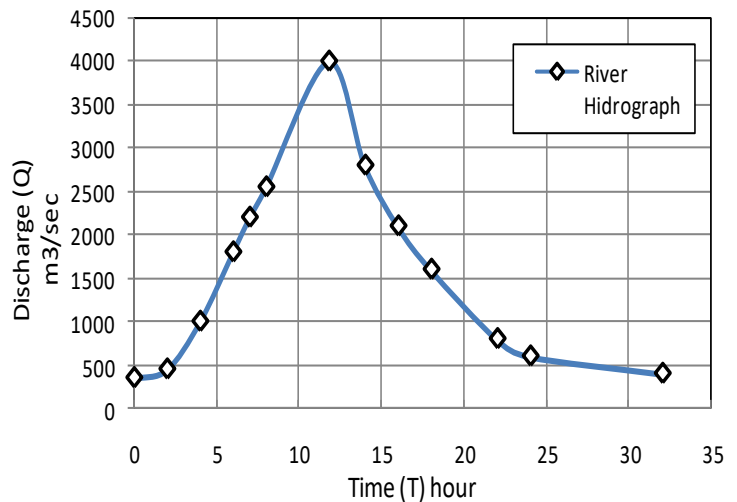

Figure.6 River Flood Hydrograph (Nippon Koei Co.,Ltd, 2009)

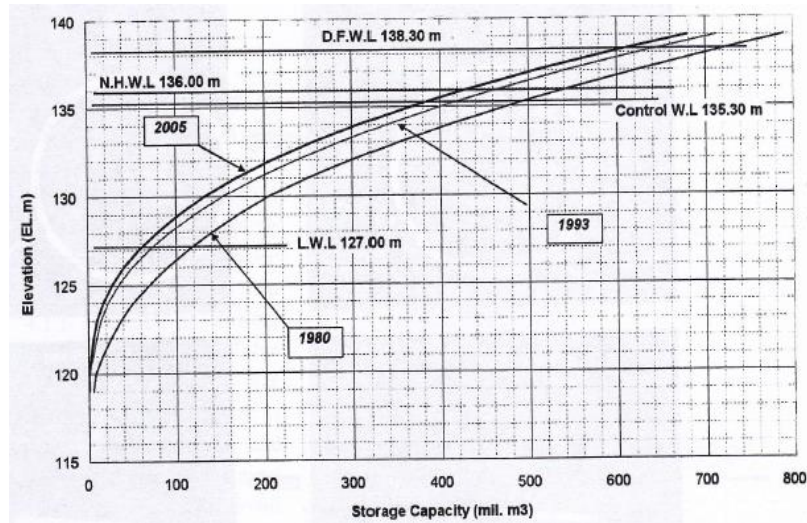

Figure .7 Elevation – Condition of the Volume in 1980,1993, 2005 (Nippon Koei Co.,Ltd, 2007)

## RESULT AND DISCUSSION

### Analysis of the Flood Hydrograph Before Sedimentation

The discharge calculation which overflows the spillway O and N, and also the flood hydrograph based on the formula on the sub chapter before, are listed in the following table:

Table.2 Relation between N and O

Elevation	Hd	Out flow	Volume	Vol/s	O/2	$N=(V/s)+(o/2)$
1	2	3	4	5	6	7
131	0	0	0	0	0	0
132	1	63	60,000,000	16667	32	16698
133	2	178	65,000,000	18056	121	18176
134	3	327	70,000,000	19444	253	19697
135	4	504	75,000,000	20833	416	21249
136	5	704	81,000,000	22500	604	23104
137	6	926	85,000,000	23611	815	24426
138	7	1167	90,000,000	25000	1046	26046
139	8	1426	110,000,000	30556	1296	31852
140	9	1701	140,000,000	38889	1563	40452
141	10	1992	200,000,000	55556	1847	57402

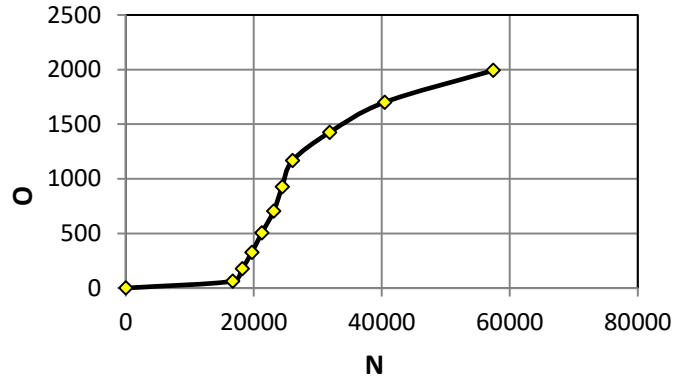

Figure 8. Relation of N-O graph

Table.3 Flood Hydrograph Analysis

Time	Inflow	Average Inflow	dN	N2=N1+dN	O	Time	Inflow	Average Inflow	dN	N2=N1+dN	O
0	350	175	175	175	0	17	2750	2425	1087	30967	1387
1	400	375	375	550	2	18	1600	2175	788	31755	1422
2	450	425	423	973	4	19	1400	1500	78	31833	1425
3	600	525	522	1495	6	20	1200	1300	-125	31708	1419
4	1000	800	794	2289	9	21	950	1075	-344	31364	1404
5	1400	1200	1191	3480	13	22	800	875	-529	30835	1381
6	1800	1600	1587	5067	19	23	650	725	-656	30179	1351
7	2200	2000	1981	7049	26	24	600	625	-726	29453	1319
8	2550	2375	2349	9397	35	25	575	588	-732	28721	1286
9	3000	2775	2740	12137	45	26	550	563	-724	27998	1254
10	3500	3250	3205	15342	57	27	530	540	-714	27284	1222
11	3800	3650	3593	18935	237	28	500	515	-707	26577	1190
12	3900	3850	3613	22548	644	29	490	495	-695	25882	1142
13	3400	3650	3006	25554	1094	30	475	483	-660	25222	1045
14	2800	3100	2006	27560	1235	31	460	468	-578	24645	959
15	2400	2600	1365	28925	1295	32	400	430	-529	24116	874
16	2100	2250	955	29880	1338						

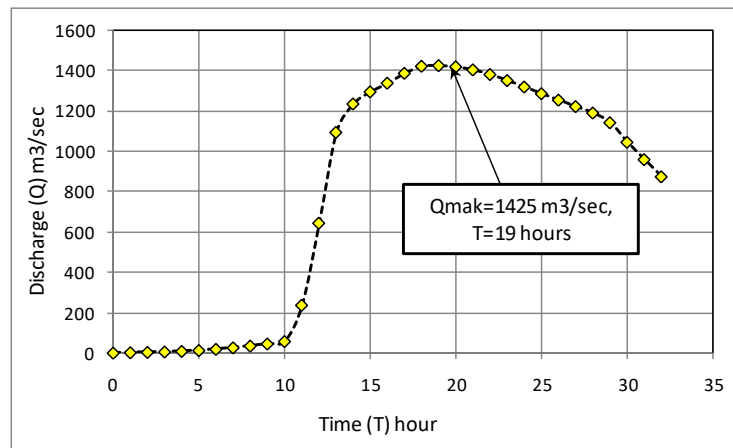

Figure.9 Flood Hydrograph after having the Reservoir



## The Flood Hydrograph Analysis After Sedimentation

Table.4 Relation between N and O

Elevation	Hd	Out flow	Volume	Vol/s	O/2	$N=(V/s)+(O/2)$
1	2	3	4	5	6	7
131	0	0	0	0	0	0
132	1	63	40,000,000	11111	32	11143
133	2	178	50,000,000	13889	121	14009
134	3	327	60,000,000	16667	253	16919
135	4	504	62,000,000	17222	416	17638
136	5	704	65,000,000	18056	604	18660
137	6	926	70,000,000	19444	815	20260
138	7	1167	80,000,000	22222	1046	23269
139	8	1426	85,000,000	23611	1296	24907
140	9	1701	90,000,000	25000	1563	26563
141	10	1992	100,000,000	27778	1847	29624

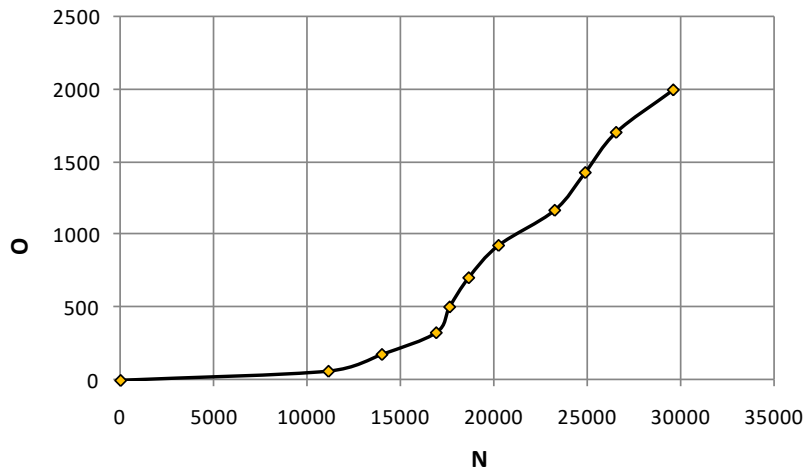

Figure.10 Relation N-O Graph

Table.5 Flood Hydrograph Analysis

Time	Inflow	Average Inflow	dN	N2=N1+dN	O	Time	Inflow	Average Inflow	dN	N2=N1+dN	O
0	350	175	175	175	1	17	2750	2425	616,6	28478	1912
1	400	375	374	549	3	18	1600	2175	263,3	28741	1987
2	450	425	422	971	5	19	1400	1500	-486,6	28255	1994
3	600	525	520	1490	8	20	1200	1300	-693,6	27561	1982
4	1000	800	792	2282	13	21	950	1075	-907,2	26654	1950
5	1400	1200	1187	3469	20	22	800	875	-1074,5	25579	1899
6	1800	1600	1580	5049	29	23	650	725	-1174,2	24405	1837
7	2200	2000	1971	7021	40	24	600	625	-1211,8	23193	1768
8	2550	2375	2335	9356	53	25	575	588	-1180	22013	1696
9	3000	2775	2722	12078	100	26	550	563	-1134	20879	1575
10	3500	3250	3150	15228	240	27	530	540	-1035	19844	1458
11	3800	3650	3410	18638	701	28	500	515	-942,5	18902	1344
12	3900	3850	3149	21787	1048	29	490	495	-849,2	18053	1234
13	3400	3650	2602	24389	1257	30	475	483	-752	17301	1148
14	2800	3100	1843	26232	1503	31	460	468	-681	16620	1102
15	2400	2600	1097	27329	1718	32	400	430	-672	15948	1060
16	2100	2250	532,4	27861	1808						

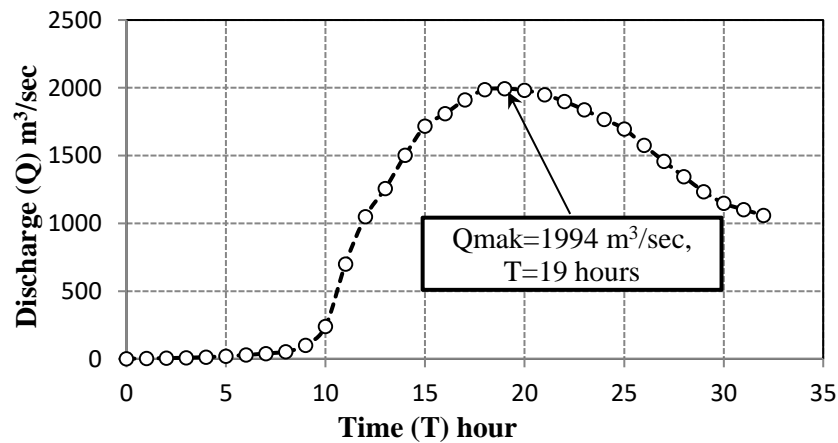

Figure.11 Flood Hydrograph After Sedimentation

**Discussion**

The peak hydrograph of the river flood before the reservoir is built is 4000 m<sup>3</sup>/s after 11.8 hours (Fig.6), and after the reservoir building (before sedimentation), the peak discharge reduces to 1425 m<sup>3</sup>/sec after 19 hours (Fig.9). The Reservoir that used to control the flood reduces the flood by 2575 m<sup>3</sup>/sec.

After the time passes, the sedimentation in the reservoir which is distributed in the death storage is 41.10%, in the operational space is 13.40%, and in the the flood control space is 0.90%. The sedimentation reduces the reservoir capacity and consequently, it reduces the reservoir capability to reduce the flood. The hydrograph of the peak flood after the sedimentation is 1994 m<sup>3</sup>/sec after 19 hours (Fig.11), which means that the ability to reduce the flood decreases by 570 m<sup>3</sup>/s compared to the reservoir ability before the sedimentation ( look at the Figure.12).

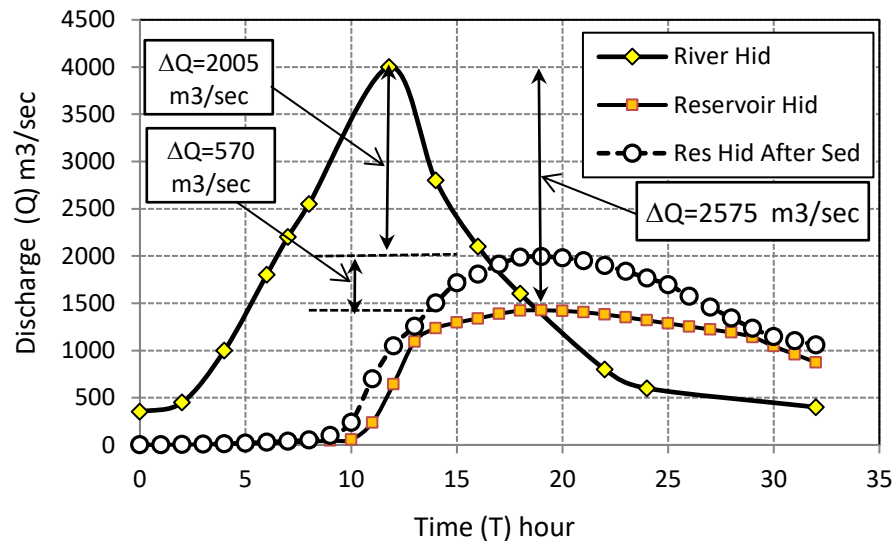

Figure.12 The Hydrographh of the River Flood – After Reservoir building and After Sedimentation occurs

The sedimentation will affect the reservoir ability to reduce the flood significantly when it has been around the spillway elevation and/or on it. It happened because the alleviation of the volume on its elevation will affect the discharge damping. From the data of the sedimentation distribution, 13.40% is in the operational space (between elevation of 127-136 m), whereas in the elevation of spillway mercu is +131m. The reduction volume cause of sedimentation on the operational space (13.40 %) is equivalent with 58 million m<sup>3</sup>, so that it significantly has an effect toward the ability to reduce the flood. That occurs because it reduces capability of the reservoir damping.

## CONCLUSION AND RECOMMENDATION

### Conclusion

The reservoir functions as the flood control because it can reduce the magnitude of the peak flood discharge . From the previous analysis, the reservoir had the sedimentation by 16% at 1980

until 2005 (settled under the elevation +138,30m). Initially the reservoir can reduce the discharge of the flood peak by 2575 m<sup>3</sup>/sec, that is from 4000 m<sup>3</sup>/sec into 1425 m<sup>3</sup>/sec.

On the subsequent analysis, after the reservoir has the sedimentation, it can only reduce the peak discharge by 2575 m<sup>3</sup>/sec, that is from 4000 m<sup>3</sup>/dt into 1995 m<sup>3</sup>/sec. Therefore, it can be concluded that the reservoir ability to decrease the peak discharge declines, which is caused by the sedimentation (reduced by 570m<sup>3</sup>/dt), or in other words, the sedimentation will have an effect toward the reservoir function as the flood control.

### **Recommendation**

The research is conducted based on the condition of the reservoir storage in 1980 and 2005. It merely compares two conditions at one reservoir. The conclusion is taken only by comparing those two conditions. To get the better image and to draw a sharper conclusion of the correlation of the flood control ability as a consequent of sedimentation, further research needs to be conducted by having an analysis with the longer data and several variations of the reservoir conditions.

### **REFERENCES**

- Chadwick.A, and Morffet.J, 1994. *Hydraulics in Civil and Environmental Engineering*, page 317-322, E&FN Spon, London.
- Gosschalk.E.M, 2002. *Reservoir Engineering, Guidelines For Practice*, page 15-21, Thomas Telford, London.
- JICA, Nippon koei Co.,Ltd, 2007 b, *The Study on Counter Measure for Sedimentation in The Wonogiri Multipurpose Dam Reservoir The Republic of Indonesia,Final Report Volume-III*
- Morris G.L, Fan J, 1998, *Reservoir Sedimentation Handbook Design and Management of Dam,Reservoir, and Watersheds for Sustainable Use*, McGraw-Hill Companies,Inc., New York.
- Nippon Koei Co.,Ltd, 2009. *Destail Design of Structural Countermeasures for Sedimentation on Wonogiri Reservoir, Volume III*
- Vanoni, V,1975, *Sedimentation Engineering*. ASCE Task Committee for the Preparation of the Manual on Sedimentation of the Sedimentation Divison.