

## BAB II

### PERHITUNGAN RENCANA GARIS (*LINES PLAN*)

#### A. PERHITUNGAN DIMENSI KAPAL

##### A.1 Panjang Garis Air Muat ( $L_{wl}$ ) \*<sup>1</sup>

$$\begin{aligned} L_{wl} &= L_{pp} + 2 \% \times L_{pp} \\ &= 27,50 \text{ m} + (2 \% \times 27,50 \text{ m}) \\ &= 28,05 \text{ m} \end{aligned}$$

##### A.2 Panjang *Displacement* ( $L_{Displ}$ ) \*<sup>2</sup>

$$\begin{aligned} L_{Displ} &= 0,5 \times (L_{wl} + L_{pp}) \\ &= 0,5 \times (28,05 \text{ m} + 27,50 \text{ m}) \\ &= 27,775 \text{ m} \end{aligned}$$

##### A.3 Panjang Keseluruhan Kapal (LOA)

$$\begin{aligned} LOA &= \frac{100}{94} \times 27,50 \\ &= 29,25 \end{aligned}$$

##### A.4 Koefisien Block ( $C_b$ ) menurut AYRE.

$$\begin{aligned} C_b &= 1,045 - \frac{V}{2\sqrt{L}} \\ &= 1,045 - \frac{5,144}{2\sqrt{27,50}} \\ &= 1,045 - \frac{5,144}{10,488} \\ &= 1,045 - 0,490 \\ &= 0,56 \quad \text{Memenuhi syarat} \quad (0,50 - 0,60) \end{aligned}$$

##### A.5 Coefisien *Midship* ( $C_m$ ) *Formula Arkent Bont Shocker*. \*<sup>3</sup>

$$\begin{aligned} C_m &= 0,90 - (0,1 \times \sqrt{C_b}) \\ &= 0,90 - (0,1 \times \sqrt{0,56}) \\ &= 0,83 \quad \text{Memenuhi Syarat} \quad (0,73 - 0,88) \end{aligned}$$

##### A.6 Coefisien *Prismatik* ( $C_p$ ) \*<sup>4</sup>

$$\begin{aligned} C_p &= C_b / C_m \\ &= 0,56 / 0,83 \\ &= 0,68 \quad \text{Memenuhi Syarat} \quad (0,61 - 0,70) \end{aligned}$$

<sup>1</sup> *Length Water Line Formula*. 2012. Buku Ajar Perkuliahan: Rencana Garis. Program Studi Diploma III Teknik Perkapalan: Universitas Diponegoro.

<sup>2</sup> *Length Displacement Formula*. 2012. Buku Ajar Perkuliahan: Rencana Garis. Program Studi Diploma III Teknik Perkapalan: Universitas Diponegoro.

<sup>3</sup> *Arkent Bont Shocker Formula for Midship Coefficient*. 2012. Buku Ajar Perkuliahan: Rencana Garis. Program Studi Diploma III Teknik Perkapalan: Universitas Diponegoro.

<sup>4</sup> *Troast Formula for Prismatic Coefficient*. 2012. Buku Ajar Perkuliahan: Rencana Garis. Program Studi Diploma III Teknik Perkapalan: Universitas Diponegoro.

#### A.7 Coefisien Garis Air ( $C_w$ ) \*<sup>5</sup> *Formula Troast*

$$\begin{aligned}C_w &= 0,743 \times C_b + 0,297 \\ &= 0,743 \times C_b + 0,297 \\ &= 0,73 \quad \text{Memenuhi Syarat } (0,73 - 0,81)\end{aligned}$$

#### A.8 Luas Garis Air ( $A_{wl}$ ) \*<sup>6</sup>

$$\begin{aligned}A_{wl} &= L_{wl} \times B \times C_w \\ &= 28,05 \text{ m} \times 5,70 \text{ m} \times 0,73 \\ &= 116,72 \text{ m}^2\end{aligned}$$

#### A.9 Luas *Midship* ( $A_m$ ) \*<sup>7</sup>

$$\begin{aligned}A_m &= B \times T \times C_m \\ &= 5,70 \text{ m} \times 2,30 \text{ m} \times 0,83 \\ &= 10,82 \text{ m}^2\end{aligned}$$

#### A.10 Volume *Displacement* ( $C_{Displ}$ ) \*<sup>8</sup>

$$\begin{aligned}V_{Displ} &= L_{pp} \times B \times T \times C_b \\ &= 27,50 \text{ m} \times 5,70 \text{ m} \times 2,30 \text{ m} \times 0,56 \\ &= 201,89 \text{ m}^3\end{aligned}$$

#### A.11 Coefisien *Prismatic Displacement* ( $C_p$ $Displ$ )

$$\begin{aligned}C_p \text{ Displ} &= L_{pp} / L_{Displ} \times C_p \\ &= 27,50 \text{ m} / 27,775 \text{ m} \times 0,68 \\ &= 0,67\end{aligned}$$

#### A.12 *Displacement* ( $D$ ) \*<sup>9</sup>

$$\begin{aligned}D &= Vol_{Displ} \times \gamma \times C \\ &= 201,894 \text{ m}^3 \times 1,025 \times 1,004 \\ &= 207,77 \text{ Ton}\end{aligned}$$

$\gamma$  = berat jenis air laut = 1,025 ton/m

$C$  = *coefisien* berat las = 1,004

---

<sup>5</sup> *Troast Formula for Water Line Coefficient*. 2012. Buku Ajar Perkuliahan: Rencana Garis. Program Studi Diploma III Teknik Perkapalan: Universitas Diponegoro.

<sup>6</sup> Kusna Djaya, Indra dan Moch. Sof'i. 2008. Teknik Konstruksi Kapal Jilid 1 hal: 19. Direktorat Pembinaan Sekolah Menengah Kejuruan: Departemen Pendidikan Nasional.

<sup>7</sup> Kusna Djaya, Indra dan Moch. Sof'i. 2008. Teknik Konstruksi Kapal Jilid 1 hal: 20. Direktorat Pembinaan Sekolah Menengah Kejuruan: Departemen Pendidikan Nasional.

<sup>8</sup> Kusna Djaya, Indra dan Moch. Sof'i. 2008. Teknik Konstruksi Kapal Jilid 1 hal: 27. Direktorat Pembinaan Sekolah Menengah Kejuruan: Departemen Pendidikan Nasional.

<sup>9</sup> Kusna Djaya, Indra dan Moch. Sof'i. 2008. Teknik Konstruksi Kapal Jilid 1 hal: 27. Direktorat Pembinaan Sekolah Menengah Kejuruan: Departemen Pendidikan Nasional

## B. MENENTUKAN LETAK LCB

B.1. Dengan menggunakan  $C_p$  Displacement pada grafik NSP pada  $C_p$  Displacement = 0,67. Didapat letak titik LCB (*Longitudinal Centre Bouyancy*) = 0,25 % x L Displ, dimana L Displ = 27,775 m

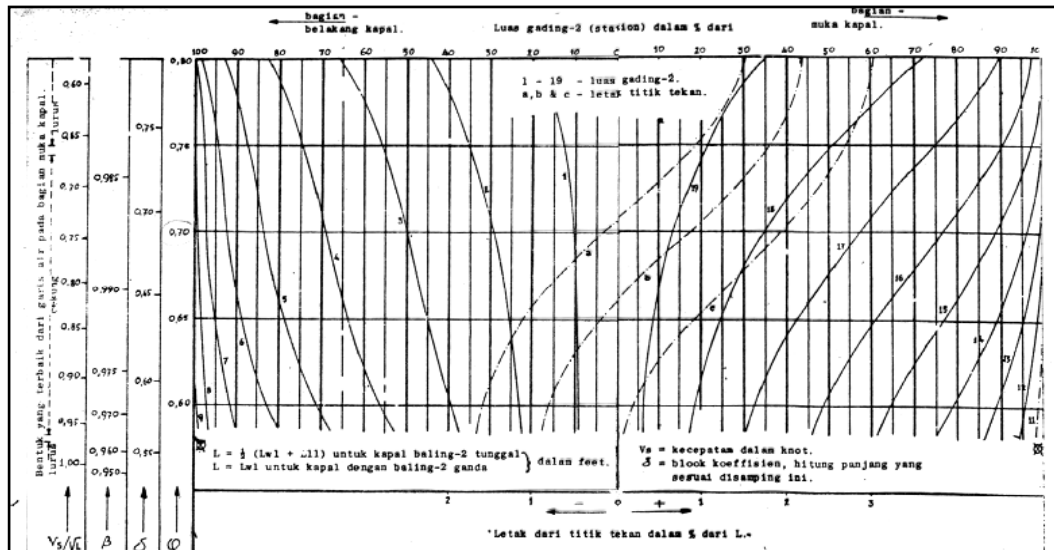

Gambar 2.1 . Grafik NSP

Gambar 2.2 Letak LCB dan Luas Station pd Grafik NSP

B.1.1. Letak LCB Displ menurut grafik NSP\*<sup>10</sup>

$$\begin{aligned} \text{LCB Displ ( b )} &= 0,25\% \times \text{L Displ} \\ &= 0,0005 \times 27,775 \text{ m} \\ &= 0,069 \text{ m ( Di depan } \textit{midship} \text{ L Displ)} \end{aligned}$$

B.1.2. Jarak *midship* (  $\phi$  ) L Displ ke FP

$$\begin{aligned} \phi \text{ Displ} &= 0,5 \times \text{L Displ} \\ &= 0,5 \times 27,775 \text{ m} \\ &= 13,88 \text{ m} \end{aligned}$$

B.1.3. Jarak *midship* (  $\phi$  ) Lpp ke FP

$$\begin{aligned} \phi \text{ Lpp} &= 0,5 \times \text{Lpp} \\ &= 0,5 \times 27,50 \text{ m} \\ &= 13,75 \text{ m} \end{aligned}$$

B.1.4. Jarak antara *midship* (  $\phi$  ) L Displ dengan *midship* (  $\phi$  ) Lpp

$$\begin{aligned} \text{a} &= \phi \text{ Displ} - \phi \text{ Lpp} \\ &= 13,88 \text{ m} - 13,75 \text{ m} \\ &= 0,137 \text{ m} \end{aligned}$$

B.1.5. Jarak antara LCB terhadap *midship* (  $\phi$  ) Lpp

$$\begin{aligned} \text{c} &= \text{b} - \text{a} \\ &= 0,14 - 0,069 \\ &= 0,068 \text{ m ( Di depan } \phi \text{ Lpp)} \end{aligned}$$

B.2. Menurut diagram NSP dengan luas tiap section ( $A_m$ ) = 10,82 m<sup>2</sup>

No. Ord	%	% Terhadap $A_m$	Fs	Hasil	Fm	Hasil
AP	0,060	0,649	1	0,649	-10	-6,491
1	0,098	1,060	4	4,241	-9	-38,166
2	0,272	2,942	2	5,885	-8	-47,080
3	0,474	5,128	4	20,511	-7	-143,576
4	0,665	7,194	2	14,388	-6	-86,327
5	0,815	8,817	4	35,266	-5	-176,332
6	0,914	9,888	2	19,775	-4	-79,101
7	0,973	10,526	4	42,103	-3	-126,310

<sup>10</sup>

Kusna Djaya, Indra dan Moch. Soffi'i. 2008. Teknik Konstruksi Kapal Jilid 1 hal: 27. Direktorat Pembinaan Sekolah Menengah Kejuruan: Departemen Pendidikan Nasional.

8	0,992	10,731	2	21,463	-2	-42,926
9	1,000	10,818	4	43,272	-1	-43,272
					S <sub>2</sub>	-789,580
10	1,000	10,818	2	21,636	0	0,000
11	1,000	10,818	4	43,272	1	43,272
12	0,976	10,558	2	21,117	2	42,233
13	0,965	10,439	4	41,757	3	125,272
14	0,915	9,898	2	19,797	4	79,187
15	0,823	8,903	4	35,613	5	178,063
16	0,682	7,378	2	14,756	6	88,534
17	0,485	5,247	4	20,987	7	146,908
18	0,291	3,148	2	6,296	8	50,368
19	0,113	1,222	4	4,890	9	44,007
FP	0,050	0,541	1	0,541	10	5,409
			S <sub>1</sub>	438,213	S <sub>3</sub>	803,253

Tabel 2.1 Diagram NSP

$$B.2.1. h = L \text{ Displ} / 20$$

$$= 27,775 \text{ m} / 20$$

$$= 1,388 \text{ m}$$

#### B.2.2. Volume Displacement

$$V \text{ Displ} = 1/3 \times h \times \Sigma_1$$

$$= 1/3 \times 1,388 \text{ m} \times 438,213 \text{ m}^2$$

$$= 202,856 \text{ m}^3$$

#### B.2.3. Letak LCB NSP

$$\begin{aligned} \text{LCB NSP} &= \frac{\Sigma_2 + \Sigma_3}{\Sigma_1} \times \frac{L_{pp}}{20} \\ &= \frac{(-789,58 + 803,25)}{438,21} \times \frac{27,775 \text{ m}}{20} \\ &= 0,043 \text{ m} \end{aligned}$$

#### B.2.4. Koreksi prosentase penyimpangan LCB\*<sup>11</sup>

$$= \frac{\text{LCB NSP} - \text{LCB displ}}{L \text{ Displ}} \times 100 \%$$

$$= \frac{0,069 - 0,043}{27,775} \times 100 \%$$

$$= 0,00094 \times 100 \%$$

$$= 0,094 \% < 0,1 \% \quad (\text{Memenuhi})$$

#### B.2.5. Koreksi prosentase penyimpangan untuk volume *Displacement*\*<sup>12</sup>

<sup>11</sup>

Koreksi Letak LCB. Tugas Rencana Garis & Buka Kulit Hal : 17. 2009. Fakultas Teknologi Kelautan : ITS..

$$\begin{aligned}
&= \frac{\text{Vol Displ Awal} - \text{Vol Displ NSP}}{\text{Vol Displ Awal}} \times 100 \% \\
&= \frac{201,894 - 202,856}{201,894} \times 100 \% \\
&= 0,004765 \times 100 \% \\
&= 0,48\% < 0,5\% \quad (\text{Memenuhi})
\end{aligned}$$

B.3. Perhitungan prismatic depan ( $Q_f$ ) dan *coefisient prismatic* belakang ( $Q_a$ ) berdasarkan tabel “*Van Lammerent*”.

Dimana :

$$\begin{aligned}
Q_f &= \textit{coefisient prismatic} \text{ bagian depan } \textit{midship} \text{ Lpp} \\
Q_a &= \textit{coefisient prismatic} \text{ bagian belakang } \textit{midship} \text{ Lpp} \\
e &= \text{Perbandingan jarak LCB terhadap Lpp} \\
e &= (\text{LCB Lpp} / \text{Lpp}) \times 100 \% \\
&= (0,068 \text{ m} / 27,50 \text{ m}) \times 100 \% \\
&= 0,2475 \%
\end{aligned}$$

Dengan rumus tersebut diatas dapat dihitung harga  $Q_a$  dan  $Q_f$  dengan rumus berikut :

$$Q_a = Q_f = \pm (1,4 + Q) \times e$$

Dimana :

$$\begin{aligned}
Q_f &= C_p + (1,4 + C_p) \times e \\
&= 0,679 + (1,4 + 0,693) \times 0,0025 \\
&= 0,684 \\
Q_a &= C_p - (1,4 + C_p) \times e \\
&= 0,679 - (1,4 + 0,679) \times 0,0025 \\
&= 0,674
\end{aligned}$$

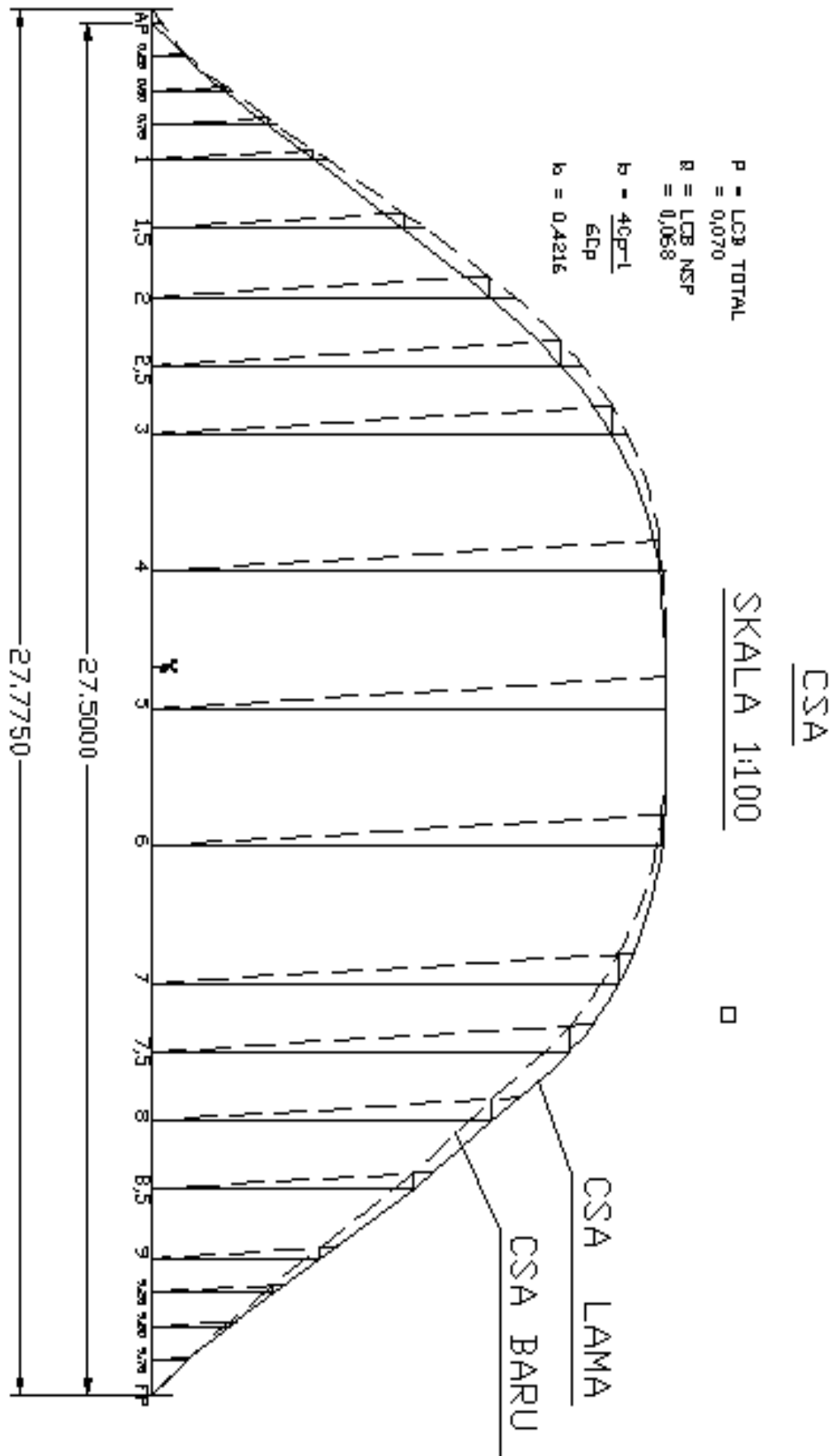

Gambar 2.3 Transformasi Titik P ke Titik Q

Tabel 2.2 Tabel *Van Lammerent*

Tabel CSA lama menurut *Van Lamerent*,  $A_m = 10,82 \text{ m}^2$

No	% luas	luas/stasion
AP	0	0,000
0,25	0,066	0,714
0,5	0,142	1,536
0,75	0,225	2,434
1	0,313	3,386
1,5	0,489	5,290
2	0,656	7,097
2,5	0,795	8,600
3	0,895	9,682
4	0,987	10,677
5	1	10,818
6	0,992	10,731
7	0,908	9,823
7,5	0,812	8,784
8	0,676	7,313
8,5	0,508	5,496
9	0,327	3,537
9,25	0,236	2,553
9,5	0,15	1,623
9,75	0,069	0,746
FP	0	0,000

110,841

Tabel 2.3 CSA lama menurut *Van Lamerent*

Perhitungan LCB dan *Volume displacement* dengan metode *van lammerent* diambil dari grafik CSA baru,  $A_m = 10,82 \text{ m}^2$

No ORD	% Luas Station	Luas Station terhadap $A_m$	FS	Hasil	Fm	Hasil
AP	0,010	0,108	0,25	0,027	-5	-0,135224218
0,25	0,045	0,487	1	0,487	-4,75	-2,312
0,5	0,125	1,352	0,5	0,676	-4,5	-3,043
0,75	0,224	2,423	1	2,423	-4,25	-10,299
1	0,324	3,505	0,75	2,629	-4	-10,515
1,5	0,514	5,560	2	11,121	-3,5	-38,923
2	0,674	7,291	1	7,291	-3	-21,874
2,5	0,812	8,784	2	17,568	-2,5	-43,921
3	0,908	9,823	1,5	14,734	-2	-29,468
4	0,971	10,504	4	42,017	-1	-42,017

5	1,000	10,818	2	21,636	0	0
					S 2	-202,506
6	0,975	10,547	4	42,190	1	42,190
7	0,910	9,844	1,5	14,766	2	29,533
7,5	0,828	8,957	2	17,915	2,5	44,786
8	0,700	7,573	1	7,573	3	22,718
8,5	0,538	5,820	2	11,640	3,5	40,740
9	0,349	3,775	0,75	2,832	4	11,326
9,25	0,250	2,704	1	2,704	4,25	11,494
9,5	0,140	1,515	0,5	0,757	4,5	3,408
9,75	0,050	0,541	1	0,541	4,75	2,569
FP	0,000	0,000	0,25	0	0	0
			S 1	221,527	S 3	208,765

Tabel 2.4 Perhitungan LCB dan volume displacement

$$\begin{aligned}
 1. \quad h &= L_{pp} / 10 \\
 &= 27,50 \text{ m} / 10 \\
 &= 2,75 \text{ m}
 \end{aligned}$$

2. *Volume Displacement* pada *Main part*

$$\begin{aligned}
 V_{\text{Displ}} &= 1/3 \times h \times \Sigma_1 \\
 &= 1/3 \times 27,50 \text{ m} \times 221,527 \\
 &= 201,036 \text{ m}^3
 \end{aligned}$$

3. Letak LCB pada *main part* :

$$\begin{aligned}
 \text{LCB}_{\text{mp}} &= \frac{\Sigma_2 + \Sigma_3}{\Sigma_1} \times \frac{L_{pp}}{10} \\
 &= \frac{-202,505 + 208,76}{221,527} \times \frac{27,50}{10} \\
 &= 0,078 \text{ m}
 \end{aligned}$$

Perhitungan pada *Cant Part*

No Ord	Luas Station	Fs	Hasil	Fm	Hasil
X	0,108	1	0,108	0	0
Y	0,054	4	0,216	1	0,216
A	0	1	0	2	0
		S <sub>1</sub>	0,325	S <sub>2</sub>	0,216

Tabel 2.5 Perhitungan *Cant Part*

$$\begin{aligned}
 e &= \frac{Lwl - Lpp}{2} \\
 &= \frac{28,05 - 27,50}{2} \\
 &= 0,275\text{m}
 \end{aligned}$$

4. *Volume displacement Cant Part*

$$\begin{aligned}
 &= 1/3 \times e \times \Sigma_1 \\
 &= 1/3 \times 0,28 \times 0,325 \\
 &= 0,03 \text{ m}^3
 \end{aligned}$$

5. LCB *Cant part* terhadap AP

$$\begin{aligned}
 &= \frac{\Sigma_2}{\Sigma_1} \times e \\
 &= \frac{0,216}{0,325} \times 0,275 \\
 &= 0,183 \text{ m}
 \end{aligned}$$

6. Jarak LCB *Cant part* terhadap  $\phi$  Lpp

$$\begin{aligned}
 &= 1/2 \times Lpp + \text{LCB } Cant \text{ part} \\
 &= 1/2 \times 27,50 \text{ m} + 0,183 \text{ m} \\
 &= 13,933 \text{ m}
 \end{aligned}$$

7. *Volume Displacement* total

$$\begin{aligned}
 V \text{ Displ Total} &= V \text{ Displ MP} + V \text{ Displ Cp} \\
 &= 201,036 \text{ m}^3 + 0,03 \text{ m}^3 \\
 &= 201,066 \text{ m}^3
 \end{aligned}$$

8. LCB total terhadap  $\phi$  Lpp

$$\begin{aligned}
 &= \frac{(\text{LCB Main Part} \times \text{Vol Main Part}) + (\text{LCB Cant Part} \times \text{Vol Cant Part})}{\text{Volume Displacement}} \\
 &= \frac{(0,0777 \times 201,036) + (13,933 \times 0,03)}{202,292} \\
 &= 0,080 \text{ m}
 \end{aligned}$$

#### B.4. Koreksi Hasil Perhitungan

a. Koreksi untuk *Volume Displacement*

$$= \frac{\text{Vol Displacement Perhitungan} - \text{Vol. Total}}{\text{Vol. Displacement Perhitungan}} \times 100 \%$$

$$= \frac{201,066 - 201,894}{201,894} \times 100 \%$$

$$= 0,0041 \times 100 \%$$

$$= 0,41 \% < 0,5 \% \quad (\text{Memenuhi})$$

b. Koreksi untuk prosentase penyimpangan LCB

$$= \frac{\text{LCB awal} - \text{LCB Total}}{\text{Lpp}} \times 100 \%$$

$$= \frac{0,080 - 0,068}{27,50 \text{ m}} \times 100 \%$$

$$= 0,00042 \times 100 \%$$

$$= 0,042 \% < 0,1 \% \quad (\text{Memenuhi})$$

## C. RENCANA BENTUK GARIS AIR

### C.1. Perhitungan Besarnya Sudut Masuk ( $\alpha$ )

Untuk menghitung besarnya sudut masuk garis air berdasarkan

*Coefisient Prismatic* Depan (Qf). Dimana :

Pada perhitungan penentuan letak LCB,  $C_p = 0,684$

Dari grafik *Latsiun* sudut masuk =  $13^\circ$

Penyimpangan =  $\pm 3^\circ$ , diambil  $-3^\circ$

Maka besarnya sudut masuk yang diperoleh =  $13^\circ + 3^\circ = 16^\circ$

Gambar 2.6 Grafik Lastlun

### C.2. Perhitungan Luas Bidang Garis Air

No. Ord.	Y=1/2 B	FS	Hasil
AP	0,8600	0,25	0,215
0,25	1,5400	1	1,540
0,5	1,9500	0,5	0,975
0,75	2,3100	1	2,310
1	2,4300	0,75	1,823
1,5	2,5590	2	5,118
2	2,6300	1	2,630
2,5	2,7100	2	5,420
3	2,7700	1,5	4,155
4	2,8400	4	11,360
5	2,8500	2	5,700
6	2,4600	4	9,840
7	2,0600	1,5	3,090
7,5	1,7600	2	3,520
8	1,4300	1	1,430
8,5	1,0900	2	2,180

9	0,7600	0,75	0,570
9,25	0,6000	1	0,600
9,5	0,4000	0,5	0,200
9,75	0,1700	1	0,170
FP	0,0000	0,25	0,000
		S	62,846

Tabel 2.7 Luas Bidang Garis Air

- a. Luas garis air pada *Main part*\*<sup>13</sup>

$$\begin{aligned}
 Awl \text{ mp} &= 2 \times \frac{1}{3} \times L_{pp}/10 \times \Sigma \\
 &= 2 \times \frac{1}{3} \times 27,50/10 \times 62,8455 \\
 &= 115,21 \text{ m}^2
 \end{aligned}$$

- b. Rencana bentuk garis air pada *Cant Part*

$$\text{Pada } \frac{1}{2} \text{ AP} = 0,86 / 2 = 0,43$$

No Ord	Tinggi Ord.	Fs	Hasil
AP	0,86	1	0,86
1/2 AP	0,43	4	1,72
0		1	0,00
		S	0,29

Tabel 2.7 Rencana Bentuk Garis Air

c. 
$$\begin{aligned}
 e &= \frac{L_{wl} - L_{pp}}{2} \\
 &= \frac{28,05 - 27,50}{2} \\
 &= 0,275 \text{ m}
 \end{aligned}$$

- d. Luas garis air pada *Cant part* ( $Awl \text{ Cp}$ )

$$\begin{aligned}
 Awl \text{ Cp} &= 2 \times \frac{1}{3} \times e \times \Sigma \\
 &= 2 \times \frac{1}{3} \times 0,275 \times 2,58 \\
 &= 1,419 \text{ m}^2
 \end{aligned}$$

- e. Luas total garis air ( $Awl \text{ Total}$ )

$$\begin{aligned}
 Awl \text{ Total} &= \text{Luas } Main \text{ part} + \text{Luas } Cant \text{ part} \\
 &= 115,21675 \text{ m}^2 + 1,419 \text{ m}^2 \\
 &= 116,636 \text{ m}^2
 \end{aligned}$$

<sup>13</sup> *Prohaska Formula*. Tugas Rencana Garis & Bukaakn Kulit Hal : 17. 2009. Fakultas Teknologi Kelautan: ITS.

f. Koreksi luas garis air

$$\begin{aligned} &= \frac{\text{Awl Perhitunga n} - \text{Awl Total}}{\text{Awl Perhitunga n}} \times 100 \% \\ &= \frac{116,716 - 116,636}{116,716} \times 100 \% \\ &= 0,00069 \quad \times \quad 100 \% \\ &= 0,069 \% \quad < \quad 0,5 \% \quad \text{(Memenuhi Syarat)} \end{aligned}$$

LUAS GARIS AIR  
SKALA 1:100

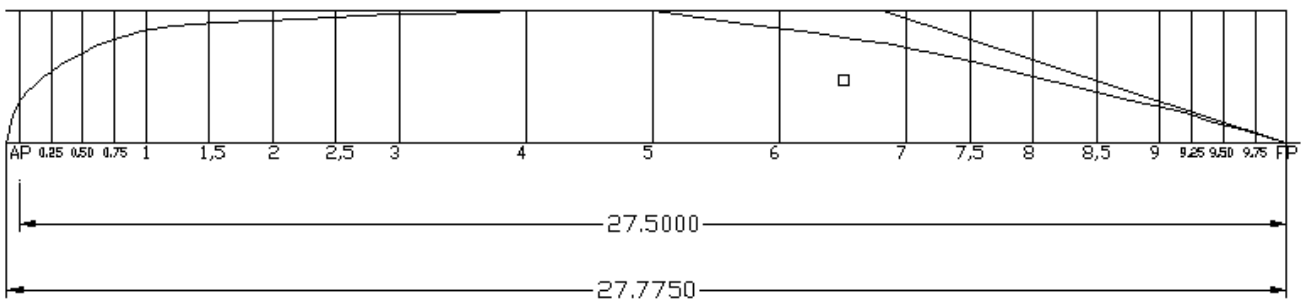

Gambar 2.4 Luas Garis Air

## D. PERHITUNGAN RADIUS BILGA

$$\text{Dimana : } B = 5,70 \text{ m}$$

$$H = 2,65 \text{ m}$$

$$T = 2,30 \text{ m}$$

$$a = \textit{Rise Of Floor}$$

$$= 0,07 \times B$$

$$= 0,07 \times 5,70$$

$$a = 0,399 \text{ m}$$

$$R = \text{Jari - jari Bilga}$$

$$M = \text{Titik pusat kelengkungan bilga}$$

### D.1. Dalam Segitiga ABC

$$\text{Tg } \alpha = \frac{AB}{BE}$$

$$= \frac{2,85}{0,399}$$

$$= 7,14$$

$$\alpha = 82,03^\circ$$

$$\beta = 180^\circ - 88,854^\circ$$

$$= 97,97^\circ$$

$$\gamma = 97,97/2$$

$$= 48,985^\circ$$

### D.2. Perhitungan

#### D.2.1. Luas Trapesium ABCD

$$= \frac{1}{2} B \times \frac{1}{2} \{ T + (T - a) \}$$

$$= 2,85 \times \frac{1}{2} \{ 2,30 + (2,30 - 0,399) \}$$

$$= 5,986 \text{ m}^2$$

#### D.2.2. Luas AFGHCDA

$$= \frac{1}{2} \text{ Luas } \textit{Midship}$$

$$= \frac{1}{2} \times B \times T \times \text{Cm} \text{ (m}^2\text{)}$$

$$= \frac{1}{2} \times 5,70 \text{ m} \times 2,30 \text{ m} \times 0,8252$$

$$= 5,409 \text{ m}^2$$



## E. PERHITUNGAN CHAMBER, SHEER DAN BANGUNAN ATAS

### E.1. Perhitungan *Chamber*

$$\begin{aligned}\text{Chamber} &= 1/50 \times B \\ &= 1/50 \times 5,70 \text{ m} \\ &= 0,114 \text{ m} \\ &= 114 \text{ mm}\end{aligned}$$

### E.2. Tinggi *Bulwark* = 1,0 m

### E.3. Perhitungan *Sheer*\*<sup>14</sup>

#### E.3.1. Bagian Buritan (Belakang)

$$\begin{aligned}\text{F.3.1.1. AP} &= 25 (L_{pp} / 3 + 10) \\ &= 25 (27,50 / 3 + 10) \\ &= 479,17 \text{ mm}\end{aligned}$$

$$\begin{aligned}\text{E.3.1.2. } 1/6 L_{pp} \text{ dari AP} &= 11,1 (L_{pp} / 3 + 10) \\ &= 11,1 (27,50 / 3 + 10) \\ &= 212,75 \text{ mm}\end{aligned}$$

$$\begin{aligned}\text{E.3.1.3. } 1/3 L_{pp} \text{ dari AP} &= 2,8 (L_{pp} / 3 + 10) \\ &= 2,8 (27,50\text{m} / 3 + 10) \\ &= 53,67 \text{ mm}\end{aligned}$$

#### E.3.2. Bagian *Midship* (Tengan) = 0 m

#### E.3.3. Bagian Haluan (Depan)

$$\begin{aligned}\text{E.3.3.1. FP} &= 50 (L_{pp} / 3 + 10) \\ &= 50 (27,50 / 3 + 10) \\ &= 958,33 \text{ mm}\end{aligned}$$

$$\begin{aligned}\text{E.3.3.2. } 1/6 L_{pp} \text{ dari FP} &= 22,2 (L_{pp} / 3 + 10) \\ &= 22,2 (27,50 / 3 + 10) \\ &= 425,50 \text{ mm}\end{aligned}$$

$$\begin{aligned}\text{E.3.3.3. } 1/3 L_{pp} \text{ dari FP} &= 5,6 (L_{pp} / 3 + 10) \\ &= 5,6 (27,50 / 3 + 10) \\ &= 107,33 \text{ mm}\end{aligned}$$

---

<sup>14</sup> *Camber Formula for Tug Boat & Fishing Vessel*. 2012. Buku Ajar Perkuliahan: Rencana Garis. Program Studi Diploma III Teknik Perkapalan: Universitas Diponegoro.

#### E.4. Bangunan Atas (Menurut *Method Varian*)

##### E.4.1. Perhitungan Jumlah Gading

Jarak gading (a)

$$\begin{aligned} a &= L_{pp} / 500 + 0,48 \\ &= 27,50 / 500 + 0,48 \\ &= 0,54 \text{ m diambil } 0,54 \end{aligned}$$

Maka :

$$\begin{aligned} 0,54 \times 50 \text{ gading} &= 27,00 \text{ m} \\ 0,50 \times 1 \text{ gading} &= \underline{0,50 \text{ m}} + \\ \text{Total} &= 27,50 \text{ m} \end{aligned}$$

##### E.4.2. *Poop deck* (Geladak Kimbul)

Panjang *Poop deck* (20 % - 30 %)  $L_{pp}$

$$\begin{aligned} \text{Panjang} &= 30 \% \times L_{pp} \\ &= 30 \% \times 27,50 \text{ m} \\ &= 8,25 \text{ m direncanakan } 8,00 \text{ m} \end{aligned}$$

Sedang tinggi *poop deck* 2,0 s/d 2,4 m diambil 2,2 m dari *main deck* bentuk disesuaikan dengan bentuk *buttock line*.

$$\begin{aligned} \text{Panjang } \textit{poop deck} &= 8,0 \text{ m} \\ \text{Direncanakan} &= (AP - 16) \\ &= 0,54 \times 6 \text{ gading} = 8,64 \text{ m} \end{aligned}$$

##### E.4.3. *Fore Castle Deck* (Deck Akil)

Panjang *Fore Castle Deck* (8 % - 15 %)  $L_{pp}$

$$\begin{aligned} \text{Panjang} &= 15 \% \times L_{pp} \\ &= 15 \% \times 27,50 \\ &= 4,13 \text{ direncanakan } 4,2 \text{ m} \end{aligned}$$

Tinggi *deck* akil (2,0 – 2,4) diambil dari 2,0 dari *main deck*

Jarak gading pada *fore castle* dengan panjang = 4,2 m

$$\begin{aligned} Fr 17 - 49 &= 0,54 \times 5 \text{ gading} = 2,7 \text{ m} \\ \underline{Fr 50 - FP} &= \underline{0,5 \times 3 \text{ gading}} = \underline{1,5 \text{ m}} \\ &= 4,2 \text{ m} \end{aligned}$$

##### E.4.4 Jarak gading pada Midship

$$0,54 \times 38 \text{ gading} = 20,52 \text{ m}$$

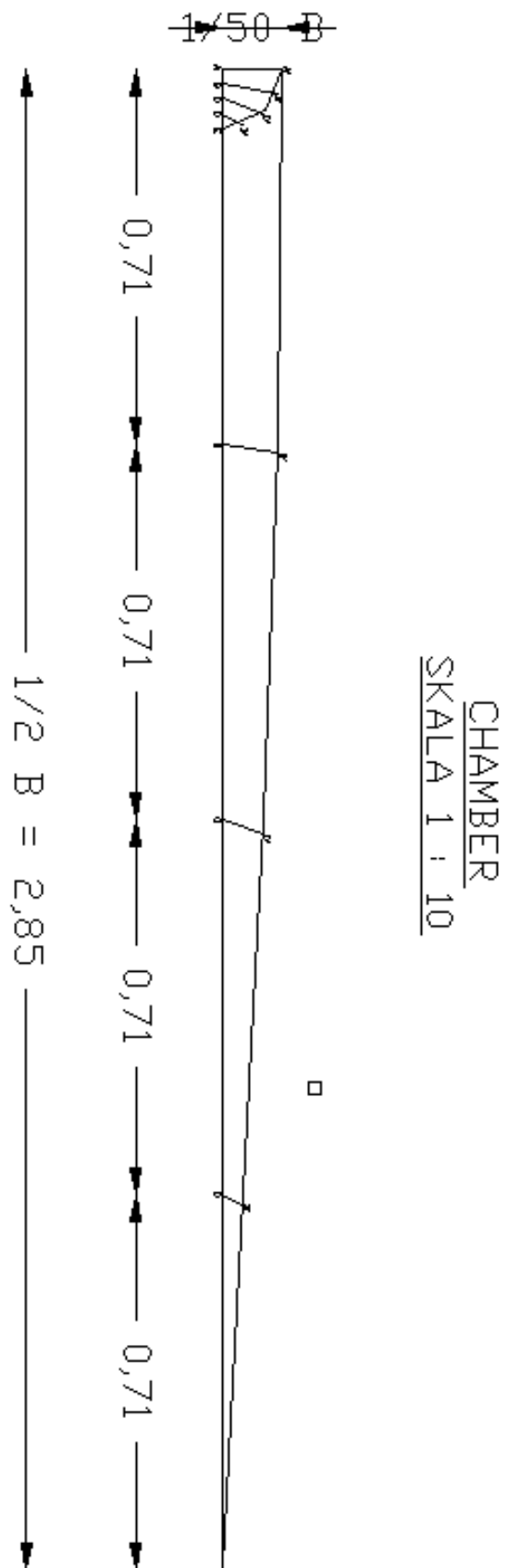

Gambar 2.6 Chamber

LPP : 27,50  
 H : 2,65  
 B : 5,70  
 T : 2,30

SHEER PLAN  
SKALA 1 : 100

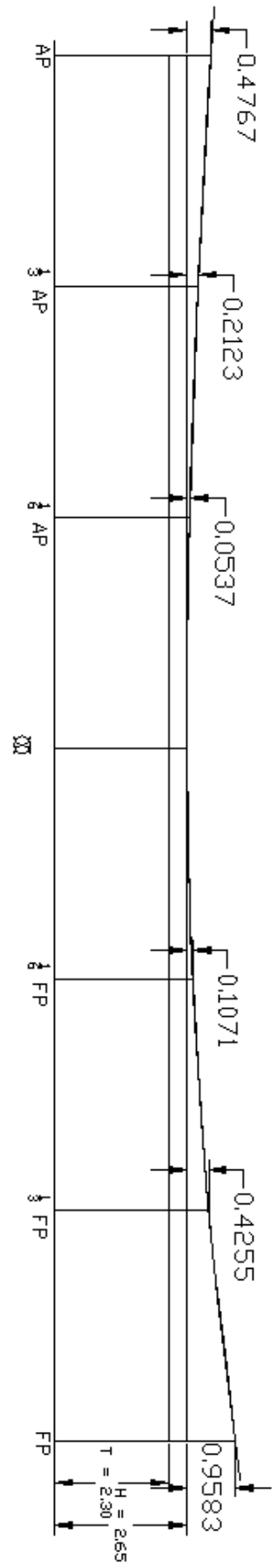

Gambar 2.7 Sheerplan

JARAK GADING  
GADING MAJOR  
GADING MINOR

: FRAME 0(A,P)-50 = 0.54  
: FRAME 50-S1(FP) = 0.5

## RENCANA JARAK GADING

SKALA 1 : 100

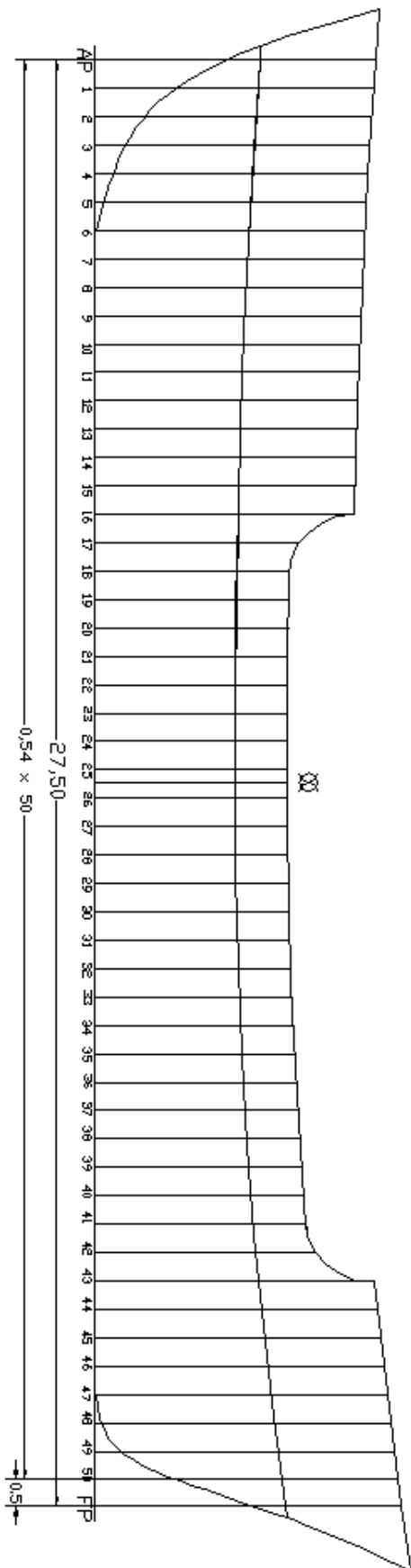

Gambar 2.8 Rencana Garis Air

## F. PERHITUNGAN UKURAN DAUN KEMUDI

Perhitungan kemudi menurut *BKI 2001 Vol II (hal 14 Sec. 14-1. A.3)*

$$A = C_1 \times C_2 \times C_3 \times C_4 \times \frac{1,75 \times L \times T}{100} \text{ (m}^2\text{)}$$

Dimana :

A = Luas daun kemudi dalam m<sup>2</sup>

L = Panjang kapal (LPP) = 27,50 m

T = Sarat kapal = 2,30 m

C<sub>1</sub> = Faktor untuk type kapal = 1

C<sub>2</sub> = Faktor untuk type kemudi = 1,0

C<sub>3</sub> = Faktor untuk profil kemudi = 0,8 (*hollow*)

C<sub>4</sub> = Faktor untuk rancangan type kemudi = 1 (Untuk Kemudi Dengan *Jet Propeller*).

$$\begin{aligned} \text{Jadi : } A &= 1 \times 1,0 \times 1 \times 1 \times \frac{1,75 \times 27,50 \times 2,30}{100} \text{ (m}^2\text{)} \\ &= 1,022 \text{ m}^2 \end{aligned}$$

### F.1. Ukuran Daun Kemudi

A = h x b      Dimana h = Tinggi daun kemudi

b = Lebar daun kemudi

Menurut ketentuan perlengkapan kapal ITS halaman 53, harga perbandingan h / b = 1,5 – 2,0

Diambil 1,5 sehingga 1,5 = h / b → h = 1,5 x b

$$A = h \times b$$

$$A = 1,5b \times b$$

$$1,33 = 1,5 \times b^2$$

$$b^2 = A / 1,5$$

$$b = \sqrt{\frac{1,33}{1,5}}$$

$$b = 0,941 \text{ m}$$

$$h = A/b$$

$$= 1,33 / 0,94$$

$$h = 1,41 \text{ m}$$

Luas bagian yang *dibalansir* dianjurkan < 23%, diambil 22 %

$$A' = 23 \% \times A$$

$$= 23 \% \times 1,33\text{m}^2$$

$$= 0,4 \text{ m}^2$$

Lebar bagian yang *dibalansir* pada potongan sembarang *horizontal*

$$b' = 33\% \times b$$

$$= 0,33 \times 0,724 \text{ m}$$

$$= 0,283 \text{ m}$$

Dari ukuran diatas dapat diambil ukuran daun kemudi :

- Luas daun kemudi (A) = 1,022 m<sup>2</sup>
- Luas bagian balansir (A') = 0,400 m<sup>2</sup>
- Tinggi daun kemudi (h) = 1,412 m
- Lebar daun kemudi (b) = 0,724 m
- Lebar bagian *balansir* (b') = 0,283 m

Koreksi luas daun kemudi (*Buku Perlengkapan kapal ITS hal 51*)

$$= \frac{0,023}{\sqrt[3]{\frac{L_{pp}}{C_b \times B} - 6,2}} < \frac{A}{L_{pp} \times T} < \frac{0,03}{\sqrt[3]{\frac{L_{pp}}{C_b \times B} - 7,2}}$$

$$= \frac{0,023}{\sqrt[3]{\frac{27,50}{0,56 \times 5,70} - 6,2}} < \frac{1,33}{27,50 \times 2,30} < \frac{0,03}{\sqrt[3]{\frac{42,20}{0,56 \times 5,70} - 7,2}}$$

$$= 0,0171429 < 0,021 < 0,0267202$$

DAUN KEMUDI  
SKALA 1 : 25

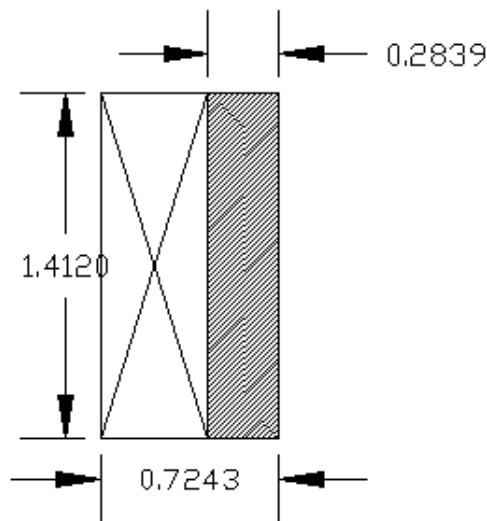

Gambar 2.9 Daun Kemudi

## G. PERHITUNGAN SEPATU KEMUDI

### G.1 Perhitungan Gaya Sepatu Kemudi

Menurut BKI 2006 Vol. II (hal. 14 - 3 Sec.B.1.1) tentang Gaya Kemudi

adalah :

$$C_R = 132 \times A \times V^2 \times k_1 \times k_2 \times k_3 \times k_t \text{ (N)}$$

Dimana :

$$A = \text{Aspek Ratio (h}^2 / A) \\ = 1,41^2 / 1,328 = 1,5$$

$$V = \text{Kecepatan dinas kapal} = 11,23 \text{ knot}$$

$$K_1 = \frac{\Delta + 2}{3} \\ = \frac{1,5 + 2}{3} \\ = 1,167 \text{ (nilainya tidak boleh lebih dari 2)}$$

$$k_2 = 1,1 \text{ (Coefisient tergantung dari rudder dan profil rudder)}$$

$$k_3 = 1,15 \text{ (untuk kemudi dibelakang propeller)}$$

$$k_t = 1,0 \text{ (normal)}$$

Jadi :

$$C_R = 132 \times 1,33 \times 126,11 \times 1,167 \times 1,1 \times 0,7 \times 1,0 \\ = 18058 \text{ N}$$

### G.2 Modulus penampang dari sepatu kemudi terhadap sumbu z, menurut BKI 2006

Vol II Hal 13.3

Dimana :

$$B_1 = \text{Gaya kemudi dalam resultan}$$

$$B_1 = C_R / 2$$

$$C_R = \text{Gaya Kemudi}$$

$$C_R = 18058 \text{ N}$$

$$B_1 = 18058 \text{ N} / 2$$

$$= 9029 \text{ N}$$

$x$  = Jarak masing-masing irisan penampang yang bersangkutan terhadap sumbu kemudi

$$x = 0,5 \times L_{50} \quad (x \text{ maximum})$$

$$x = L_{50} \quad (x \text{ maximum}), \text{ dimana :}$$

$$L_{50} = \frac{C_R}{Pr \times 10^3}$$

$$\text{Dimana } Pr = \frac{C_R}{L_{10} \times 10^3}; \quad L_{10} = \text{Tinggi daun kemudi } h = 1,41 \text{ m}$$

$$= \frac{18057,520}{1,41 \times 10^3}$$

$$= 12,79 \text{ N/m}$$

$$L_{50} = \frac{C_R}{Pr \times 10^3}$$

$$L_{50} = \frac{18057,520}{12,79 \times 10^3}$$

$$= 1,41 \text{ m diambil} = 1,62 \text{ (diambil 3 jarak gading)}$$

$$X_{\min} = 0,5 \times L_{50}$$

$$= 0,5 \times 1,62 \text{ m}$$

$$= 0,81 \text{ m (diambil 2 jarak gading} = 1,08 \text{ m)}$$

$$k = \text{Faktor bahan} = 1,0$$

$$W_Z = \frac{B1 \times X \times k}{80}$$

$$= \frac{9028,8 \times 1,10 \times 1,0}{80}$$

$$= 121,888 \text{ cm}^3$$

$$W_Y = \frac{1}{3} \times W_Z$$

$$= \frac{1}{3} \times 121,888 \text{ cm}^3$$

$$= 40,629 \text{ cm}^3$$

G.3 Perencanaan profil sepatu kemudi dengan plat dengan ukuran sebagai berikut :

$$\text{Tinggi (h)} = 100 \text{ mm}$$

$$\text{Tebal (s)} = 30 \text{ mm}$$

$$\text{Lebar} = 112 \text{ mm}$$

No	B	H	F = b x h	a	F x a <sup>2</sup>	Iz = 1/12 x b x h <sup>3</sup>		
I	11	3,00	33,6	0	0	25,2		
II	3	4,0	12	4,10	201,72	16,000		
III	3	4	12	0	0	16,000		
IV	3	4	12	4,10	201,72	16,000		
V	11,2	3	33,6	0	0	25,2		
					S <sub>1</sub>	403,44	S <sub>2</sub>	98,400

Tabel 2.8 Perencanaan Profil Sepatu Kemudi

$$\begin{aligned} I_z &= \Sigma_1 + \Sigma_2 \\ &= 403,44 + 98,4 \\ &= 501,84 \text{ cm}^4 \end{aligned}$$

$$\begin{aligned} W_z &= I_z / a \\ &= 501,84 / 4,1 \\ &= 122,400 \text{ cm}^3 \end{aligned}$$

Koreksi perhitungan Wz :

$$\begin{aligned} &= \frac{W_z' - W_z}{W_z} \times 100\% \\ &= \frac{122,400 - 121,888}{121,888} \times 100\% \\ &= 0,00042 \times 100\% \\ &= 0,42\% < 0,5\% \text{ (memenuhi)} \end{aligned}$$

SEPATU KEMUDI  
SKALA 1 : 2

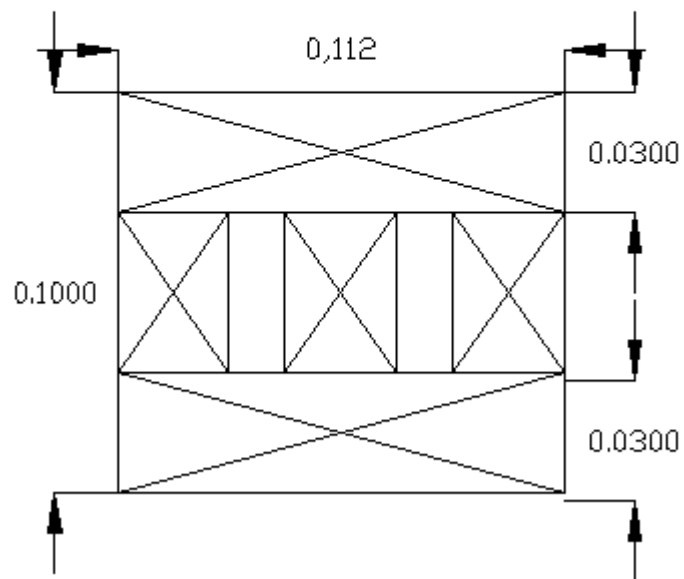

SEPATU KEMUDI  
SKALA 1 : 20

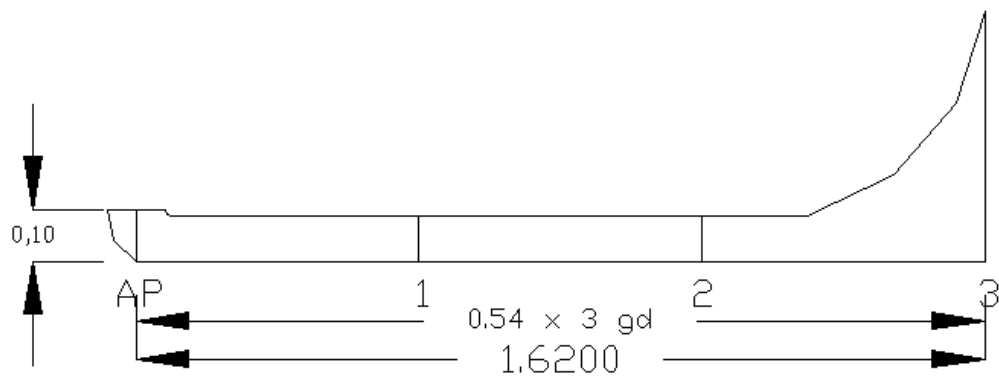

Gambar 2.10 Sepatu Kemudi

## H. PERHITUNGAN STERN CLEARANCE

Ukuran diameter *propeller* ideal adalah  $(0,6 - 0,7) T$

Dimana  $T =$  Sarat kapal

Diambil  $0,65 \times T$

$D$  *Propeller* Ideal adalah

$$= 0,6 \times T$$

$$= 0,6 \times 2,30$$

$$= 1,380 \text{ m}$$

$R$  (Jari – jari *Propeller*)

$$= 0,5 \times D \text{ *Propeller*}$$

$$= 0,5 \times 1,380$$

$$= 0,690 \text{ m}$$

Diameter Boss *Propeller*

$$= 1/6 \times D \text{ *Propeller*}$$

$$= 1/6 \times 1,380$$

$$= 0,230 \text{ m}$$

Menurut konstruksi lambung BKI, untuk kapal baling - baling tunggal jarak minimal antara baling – baling dengan linggi buritan menurut aturan konstruksi

BKI 2006 Vol II Sec 13 – 1 adalah sebagai berikut :

a.  $0,1 \times D = 0,138 \text{ m}$

b.  $0,09 \times D = 0,1242 \text{ m}$

c.  $0,17 \times D = 0,1255 \text{ m}$

d.  $0,15 \times D = 0,2070 \text{ m}$

e.  $0,18 \times D = 0,2484 \text{ m}$

f.  $0,04 \times D = 0,0552 \text{ m}$

g. 2” – 3” Diambil  $2 = 2 \times 0,0254 = 0,0508$

Jarak poros *propeller* dengan *Base Line* adalah :

$$\begin{aligned}
 &= R \text{ Propeller} + f + \text{Tinggi sepatu kemudi} \\
 &= 0,690 + 0,0552 + 0,1 \\
 &= 0,845 \text{ m}
 \end{aligned}$$

## STERN CLEARANCE SKALA 1:25

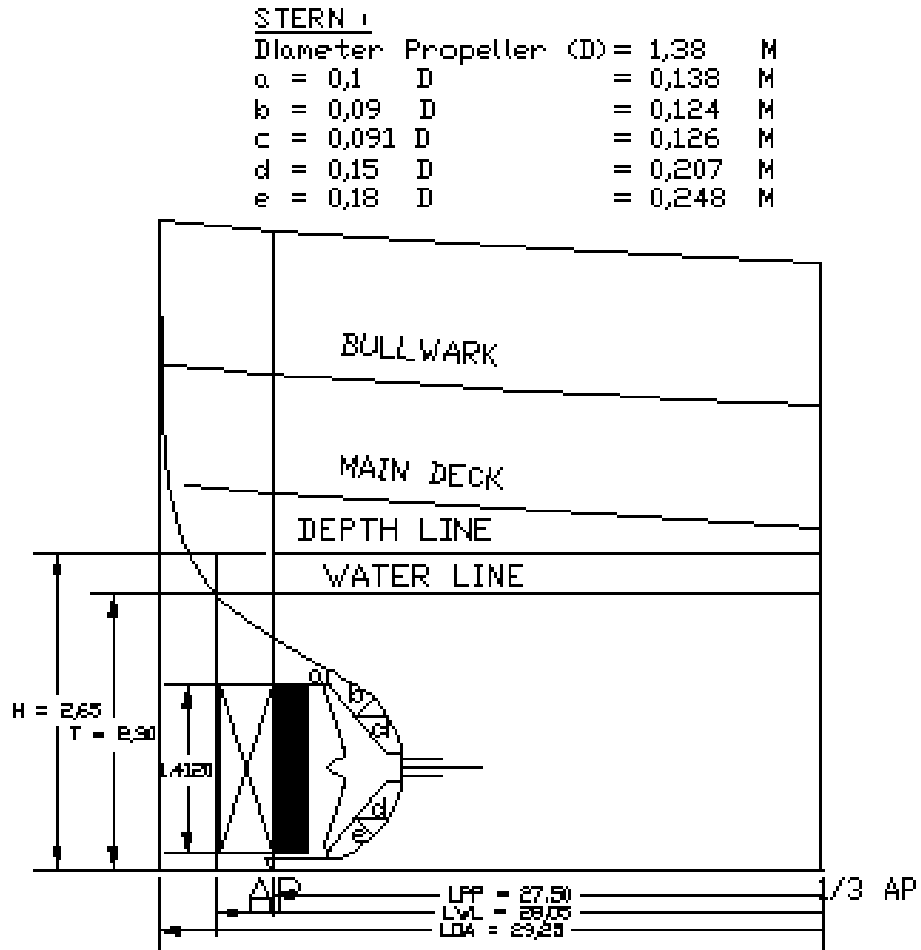

Gambar 2.11 Stern Clearance

## I. MERENCANAKAN BODY PLAN

### 1. Merencanakan bentuk *body plan* adalah

Merencanakan atau membuat bentuk garis air lengkung pada potongan ordinat.

### 2. Langkah – langkah

- Membuat empat persegi panjang dengan sisi  $\frac{1}{2} B = 3,21$  m dan  $T = 2,7$  m
- Pada garis air T diukurkan garis b yang besarnya =  $\frac{1}{2}$  luas *station* dibagi T.
- Dibuat persegi panjang ABCD
- Diukurkan pada garis air T garis air Y =  $\frac{1}{2}$  lebar garis air pada *station* yang bersangkutan.
- Dari titik E kita merencanakan bentuk *station* sedemikian sehingga luas ODE = luas OAB letak titik O dari *station – station* harus merupakan garis lengkung yang stream line.
- Setelah bentuk *station* selesai dibuat, dilakukan pengecekan *volume displacement* dari bentuk-bentuk *station*.
- Kebenaran dari lengkung – lengkung dapat dicek dengan menggunakan *Planimeter*.

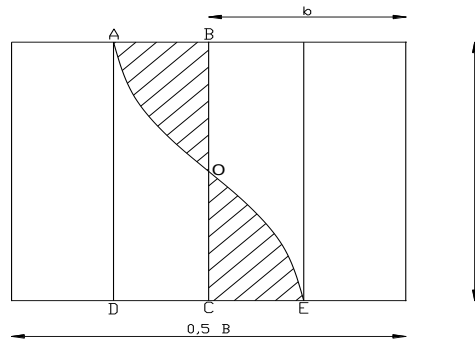

#### I.1. Rencana Bentuk *Body Plan*

$$T = 2,30 \text{ m}$$

$$2 T = 4,60 \text{ m}$$

No. Ord	Y = 1/2 B	Luas station	b = ls/2T
AP	0,86	0,108	0,024
0,25	1,54	0,487	0,106
0,5	1,95	1,352	0,294
0,75	2,31	2,423	0,527
1	2,43	3,505	0,762

1,5	2,56	5,560	1,209
2	2,63	7,291	1,585
2,5	2,71	8,784	1,910
3	2,77	9,823	2,135
4	2,84	10,504	2,284
5	2,85	10,818	2,352
6	2,46	10,547	2,293
7	2,06	9,844	2,140
7,5	1,76	8,957	1,947
8	1,43	7,573	1,646
8,5	1,09	5,820	1,265
9	0,76	3,775	0,821
9,25	0,60	2,704	0,588
9,5	0,40	1,515	0,329
9,75	0,17	0,541	0,118
FP	0,00	0	0

Tabel 2.9 Perhitungan Luas Station

I.2. Perhitungan Koreksi *Volume Displacement* Rencana *Body Plan*

No. Ord	Luas Station	FS	Hasil
AP	0,108	0,25	0,027
0,25	0,487	1	0,487
0,5	1,352	0,5	0,676
0,75	2,423	1	2,423
1	3,505	0,75	2,629
1,5	5,560	2	11,121
2	7,291	1	7,291
2,5	8,784	2	17,568
3	9,823	1,5	14,734
4	10,504	4	42,017
5	10,818	2	21,636
6	10,547	4	42,190
7	9,844	1,5	14,766
7,5	8,957	2	17,915
8	7,573	1	7,573

8,5	5,820	2	11,640
9	3,775	0,75	2,832
9,25	2,704	1	2,704
9,5	1,515	0,5	0,757
9,75	0,541	1	0,541
FP	0	0,25	0
		S	221,527

Tabel 2.10 Perhitungan Koreksi Luas Station

I.2.1. *Volume Displacement* perhitungan

$$\begin{aligned}
 V \text{ displ} &= Lpp \times B \times T \times Cb \\
 &= 27,50 \text{ m} \times 5,70 \text{ m} \times 2,30 \text{ m} \times 0,56 \\
 &= 201,894 \text{ m}^3
 \end{aligned}$$

I.2.2 *Volume displacement Cant part*

$$\begin{aligned}
 V \text{ disp Perencanaan} \\
 &= 1/3 \times LPP / 10 \times S1 \\
 &= 1/3 \times 27,50 / 10 \times 221,53
 \end{aligned}$$

I.2.3 Perhitungan pada Cant Part

No Ord	Luas Station	Fs	Hasil	Fm	Hasil
X	0,108	1	0,108	0	0
Y	0,054	4	0,216	1	0,22
A	0	1	0	2	0
		S <sub>1</sub>	0,325	S <sub>2</sub>	0,22

Tabel 2.11 Perhitungan Cant Part

$$\begin{aligned}
 e &= \frac{Lwl - Lpp}{2} \\
 &= \frac{28,05 \text{ m} - 27,50 \text{ m}}{2} \\
 &= 0,275 \text{ m}
 \end{aligned}$$

I.2.4 *Volume displacement Cant part*

$$\begin{aligned}
 V \text{ disp CP} &= 1/3 \times e \times \sum_1 \\
 &= 1/3 \times 0,275 \times 0,325 \\
 &= 0,03 \text{ m}^3
 \end{aligned}$$

#### I.2.5 *Volume Displacement* total

$$\begin{aligned}V_{\text{displ Tot}} &= V_{\text{disp MP}} + V_{\text{disp CP}} \\ &= 202,863 \text{ m}^3 + 0,03 \text{ m}^3 \\ &= 202,893 \text{ m}^3\end{aligned}$$

#### I.2.4. Koreksi penyimpangan *volume displacement body plan*

$$\begin{aligned}&= \frac{V_{\text{Vol Displ. Perhitunga n}} - V_{\text{Vol. Displ total}}}{V_{\text{Vol. Displ. perhitunga n}}} \times 100 \% \\ &= \frac{202,890 - 201,894}{201,894} \times 100 \% \\ &= 0,0049 \times 100 \% \\ &= 0,49\% < 0,5 \% \quad (\text{Memenuhi syarat})\end{aligned}$$

BODY PLAN  
1:50

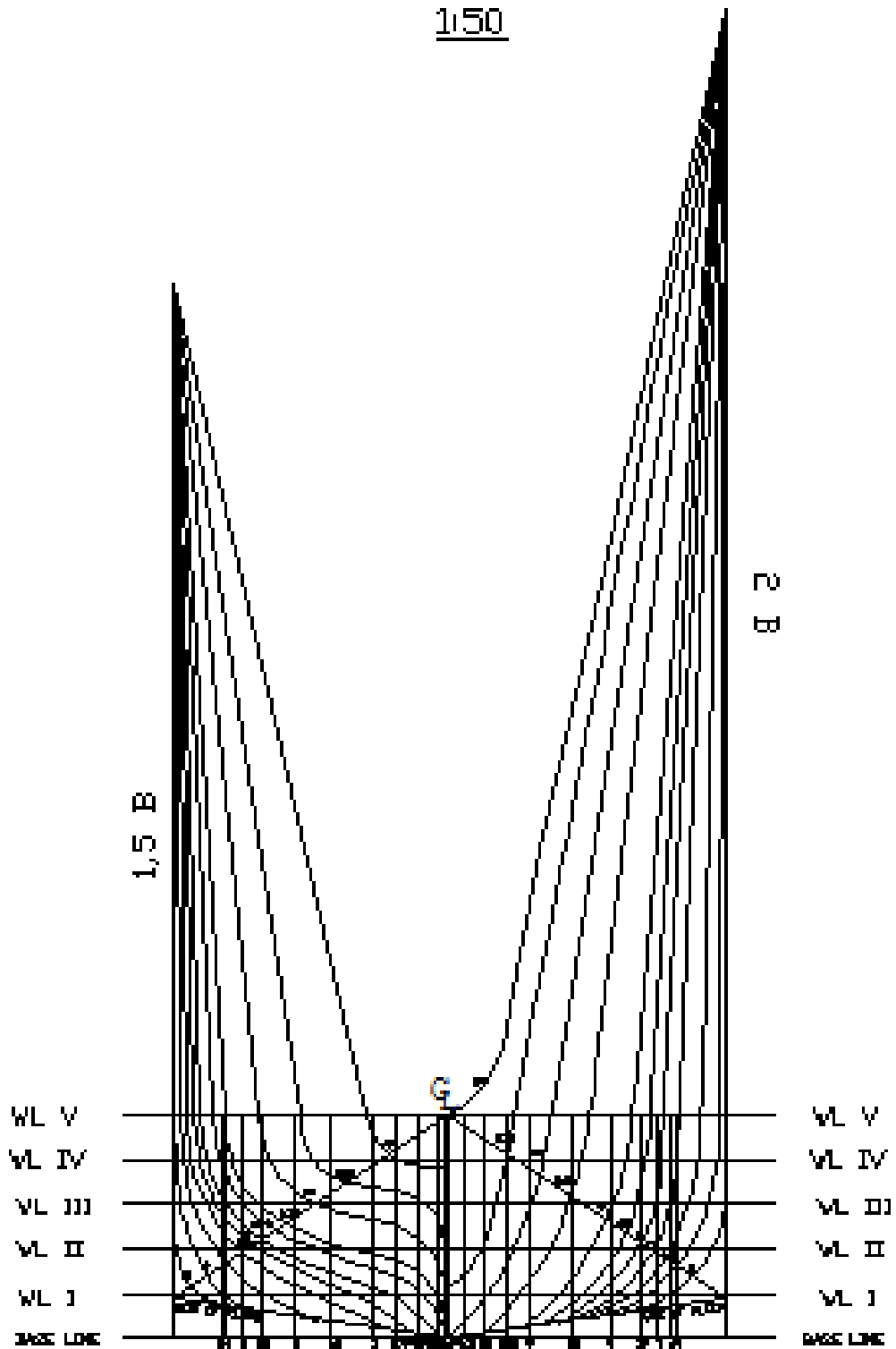

Gambar 2.12 Body Plan