

MANNAN PRECIPITATION FROM *ALOE VERA* LEAF PULP JUICE USING METHANOL AND ISOPROPYL ALCOHOL AS ANTI-SOLVENT: EXPERIMENTAL AND EMPIRICAL MODELLING APPROACH

Diah Susetyo Retnowati^{*)} and Andri Cahyo Kumoro

Department of Chemical Engineering, Faculty of Engineering, Diponegoro University,
Jl. Prof. H. Soedarto, SH, Tembalang, Semarang, 50275, Telp. (024) 7460058, Fax. (024) 76480675

^{*)}Corresponding author: diahsusetyo@gmail.com

Abstract

Precipitation of mannan from Aloe vera leaf pulp juice was investigated using anti-solvent precipitation process under room temperature condition. The aims of this work were to study the effects of types (methanol and isopropyl alcohol) and amount of anti-solvent on the precipitation phenomena and to propose a simple mathematics model for evaluating the precipitation rate of mannan (R_p). The experiments were carried out using a semi batch system; where continuous drop wise addition of anti-solvent to the Aloe vera leaf pulp juice was kept constant at 50.4 mL/min, while the speed of stirring was maintained at 675 rpm. At every run of the experiments, the time at which the precipitation began was recorded and the experiment was terminated when no further precipitation occurred. The samples were withdrawn from the system at every 25 min after the first precipitation for mannan analysis. The results of this work showed that isopropyl alcohol acted as a more effective anti-solvent to precipitate mannan from Aloe vera leaf pulp juice than methanol. The mathematics model represented the precipitation phenomena fairly well with average relative deviation only 11.73%, and finally suggested that the precipitation rate obeyed the zero order.

Keywords: *aloe vera; anti-solvent; isopropyl alcohol; mannan; methanol; rate of precipitation*

Abstrak

PENGENDAPAN MANNAN DARI JUS DAGING DAUN LIDAH BUAYA (*ALOE VERA*) MENGGUNAKAN METANOL DAN ISOPROPIL ALKOHOL SEBAGAI ANTI SOLVEN: PERCOBAAN DAN PEMODELAN DENGAN PENDEKATAN EMPIRIK. *Pengendapan mannan dari jus daun lidah buaya (*Aloe vera*) dengan teknik pengendapan menggunakan anti-pelarut dikaji pada suhu kamar. Tujuan dari penelitian ini adalah untuk mempelajari pengaruh jenis anti-pelarut (metanol dan isopropil alkohol) dan massa anti-pelarut terhadap fenomena pengendapan mannan, serta mengembangkan model matematik dengan pendekatan empiric untuk mengevaluasi laju pengendapan mannan (R_p). Percobaan dilakukan dalam sistem yang bekerja secara semi-batch, dengan anti-pelarut diumpankan secara terus menerus dalam bentuk tetesan-tetesan dengan laju 50,4 mL/menit dan pengadukan dijaga tetap pada 675 putaran per menit (rpm). Pada setiap percobaan, waktu yang diperlukan sejak pengumpanan anti-pelarut hingga saat endapan pertama kali terbentuk dicatat, dan percobaan dihentikan jika tidak ada lagi endapan yang terbentuk. Cuplikan cairan diambil setiap 25 menit sejak endapan pertama terbentuk dan dianalisis kandungan mannannya. Hasil penelitian menunjukkan bahwa isopropil alkohol merupakan anti-pelarut yang lebih efisien dibandingkan dengan metanol untuk mengendapkan mannan dari jus daun lidah buaya. Dari pemodelan matematik diketahui bahwa laju pengendapan mannan mengikuti order nol. Model matematik yang diusulkan dapat mewakili fenomena pengendapan mannan dengan baik yang ditunjukkan dengan ralat rata-rata sebesar 11,73%.*

Kata kunci: *aloe vera; anti-pelarut; isopropil alkohol; mannan; metanol; laju pengendapan*

INTRODUCTION

Precipitation is a common separation process found in the industrial processes. To date, there are

two methods extensively used for precipitation, namely evaporation and cooling crystallization. However, there is an alternative method to be worth

considered for precipitation of substance from a solution. The precipitation can be done by adding another specific substance, which is miscible with the solvent of the solution, but does not dissolve the solute (Mullin, 2001). As a result, the solution becomes saturated and precipitation begins. The added substance could be known as the precipitant, secondary solvent, anti-solvent or co-solvent (Mullin, 2001; Pina *et al.*, 2001). This process has various terms and one of them is called anti-solvent precipitation.

Although both crystallization and anti-solvent precipitation processes are conducted to produce sediments, the anti-solvent precipitation process has shown its superiorities over the former. First of all, anti-solvent precipitation can be done at room temperature, which is more convenient. This condition sometimes is needed if the precipitated substances are very sensitive to heat, especially for pharmaceutical products. This operation is a little bit of temperature function; therefore, the energy consumption for this technique is less than the evaporative crystallization (Nowee, 2008). In addition, the crystal obtained from this operation has reported to have higher purity (Tóth *et al.*, 2005) than crystallization process since the mixed solvent often retains the impurities better (Mullin, 2001; Takiyama *et al.*, 1998). Unfortunately, the anti-solvent precipitation also some disadvantages. It generates abundant mother liquor or used mixed solvent, which needs to be separated each other for further reuse (Hyung *et al.*, 2006). This process often produces variety of shape crystals as operating condition differ, i.e. precipitation of sodium chloride using aqueous ethanol as anti solvent produces rod and plate crystals (Takiyama *et al.*, 1998).

In this article, the anti-solvent precipitation is applied to produce mannan from *Aloe vera* leaf pulp juice, a heat sensitive polysaccharide with various pharmaceutical and food functional properties (Ni *et al.*, 2004). Mannan is mainly composed of glucose and mannose units (Hamman, 2008). In general, the repeating units of glucose and mannose present in a ratio of 1:3, but other ratios of 1:6, 1:15 and 1:22 have also been found in the literatures. The differences in glucose to mannose ratios have been explained by the differences between species/cultivars as well as due to differences in processing and treatment method (Eshun and He, 2004; Boudreau and Beland, 2006). Reviewed from its molecular structure, mannan is a very polar and a water soluble substance (Hamman, 2008). Therefore, Feminia *et al.* (1999) reported that addition of 80% aqueous ethanol, which is less polar than water to the solution of this polysaccharide promoted precipitation. Alcohol acted as an anti-solvent leading to the reduction of mannan solubility from which precipitation began. Based on the above mentioned facts, methanol and isopropyl alcohol were then employed as anti-solvent and the amount of the addition of those anti-solvents was also varied for the investigation of mannan precipitation rate and an

empirical model was then proposed. The result obtained in this work might be required as a basic data for the design of equipments for the anti-solvent precipitation of mannan for pharmaceutical and food industries.

MODELLING OF THE KINETICS OF ANTI-SOLVENT PRECIPITATION SYSTEM

As the anti-solvent precipitation system in this study was carried out isothermally, the precipitation phenomena was assumed to be dependent only on the composition of the mixed solvent (solvent + anti-solvent). In this case, the solute, solvent and the anti-solvents were mannan, water, and methanol or isopropyl alcohol, respectively. The condition, at which the first precipitation occurred, is named as β_0 . It was indicated by the first time mannan precipitated, t_1 . While, the conditions at which the precipitation occurred in the anti-solvent precipitation system for any time can be expressed as β .

Precipitation is a time-dependent process. Therefore, the rate of precipitation specifies the maximum supersaturation value that can be reached. The precipitation rate at a constant temperature can be expressed empirically in general form and applied to any system:

$$R_{\beta} = K_v \beta^n \quad (1)$$

Where $R_{\beta} = d\beta/dt$, K_v and n are precipitation rate constant and order, respectively.

Through integration process, with boundary condition at $t = t_1$, $\beta = \beta_0$ and at $t = t$, $\beta = \beta$, equation (1) becomes:

For $n = 1$

$$\beta = \beta_0 e^{K_v(t-t_1)} \quad (2.a)$$

For $n \neq 1$

$$\beta = [(\beta_0 \cdot (1-n)) + K_v \cdot (t-t_1)(1-n)]^{1/(1-n)} \quad (2.b)$$

where β_0 and t_1 are the weight and time of the first precipitation occurred.

The model was verified its accuracy by comparing the β values obtained from equation (2.a or 2.b) called as β_{calc} and β values obtained from the experiment (β_{exp}). The values of K_v and n were evaluated using multivariable optimization to obtain minimum value of SSE with the assistance of Matlab software.

$$\text{Min}(SSE) = \sum_1^m (\beta_{exp} - \beta_{calc})^2 \quad (3)$$

where m is the number of data. The average relative deviation (ARD) between β_{exp} and β_{calc} was then calculated by equation:

$$\text{ARD} = 1/m \sum_1^m \left| \frac{(\beta_{exp} - \beta_{calc})}{\beta_{exp}} \right| \quad (4)$$

MATERIAL AND METHODS

Material

Aloe vera fresh leaves were harvested from a botanical garden at the Chemical Engineering

Department, Faculty of Engineering Diponegoro University, Semarang-Indonesia. The deionized water was obtained from reverse osmosis equipment available in the same institution. Technical grade methanol (82% w/w purity) and isopropyl alcohol (70% w/w purity) were purchased from an authorized chemical distributor in Semarang. Alcohols impurities were considered as only water.

Apparatus

The equipment used in this study was depicted in Figure 1. It consisted of an isothermally agitated vessel and a drop-wise anti-solvent feeder.

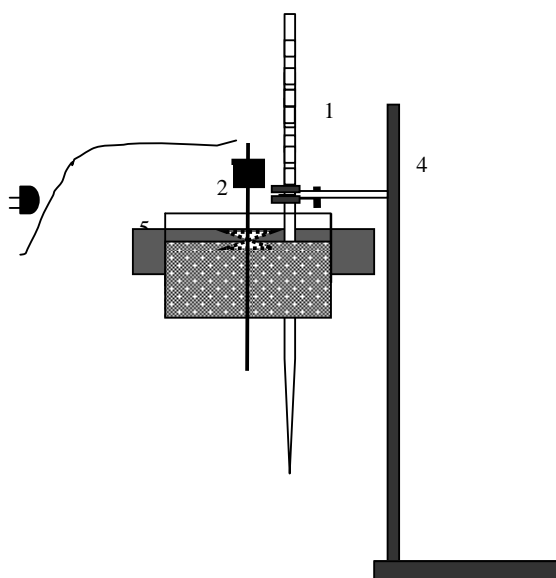

Figure 1. Experimental set-up for conducting precipitation study, (1) burette for adding alcohol, (2) electric agitator, (3) precipitation chamber, (4) stand and holder, (5) aloe vera leaf pulp juice

Procedure

Aloe vera leaves were peeled, drained off the yellow sap and washed with deionized water. Three hundreds grams of the clear pulp was juiced using laboratory scale juicer/juice extractor (Green Power Co. Model GP-E1503 Gold, Anaheim, CA, USA) for 15 menit. The extract was separated as supernatant I, and the pellet, as pellet I. Pellet I was then further extracted using water which it was 4 fold weight of the pellet at 45 minutes (from isolation process by Ni *et al.*, 2004, the pellet still have mannose content 30% than the supernatant I). After this extraction, the supernatant (supernatant II) was removed by centrifugation. Supernatant I and II were mixed for anti-solvent precipitation investigation.

The precipitation experiments were carried out using a semi batch system (Figure 1); where continuous drop wise addition of anti-solvent to the *Aloe vera* leaf pulp juice was kept constant at 50.4 mL/min, while the speed of stirring was maintained at

675 rpm. At every run of the experiments, the time at which the precipitation began was recorded and the experiment was terminated when no further precipitation occurred even with further addition of anti-solvent. The liquid samples were withdrawn from the system at every 5 min after the first precipitation for mannan analysis according to Schorger method (Schorger, 1917).

RESULTS AND DISCUSSION

Precipitation may occur, if a solution reaches supersaturated condition, which is generated by the difference of solubility's of the solute in the solvent and anti-solvent phase. In this study, supersaturated condition of mannan-water system was created by addition a certain amount of anti-solvent (methanol or isopropyl alcohol) to *Aloe vera* leaf pulp juice. Figure 2 shows the mannan precipitation in the mixtures of water + methanol and water + isopropyl alcohol, ranging from 0-65% w/w. It is clearly shown in Figure 2 that the amount of mannan precipitated raised with the increase amount of anti-solvent. Mannan as a polar solute of highly water-soluble is induced by the addition of methanol or isopropyl alcohol, which they are miscible in water. Methanol and isopropyl alcohols modify the structure, properties and behavior of the mannan-water electrolytic solution. The dielectric constant, ϵ , which is closely related to the molecular interactions of the solution, will change as a result of solvent + anti-solvents mixing. The interactions include the dipolar interaction as well as electron transfer bonding via hydrogen bonding and acid base interaction (Babu *et al.*, 2007).

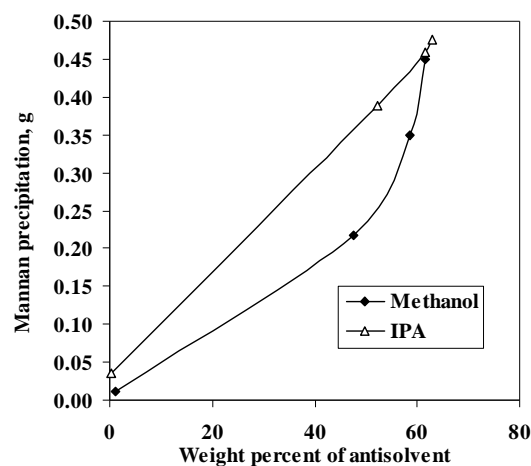

Figure 2. Mannan precipitation in various water + antisolvent systems at room temperature

According to Akerlof (1932), the ϵ values for pure water at room temperature, 30°C, is 76.73, while the ϵ values for methanol and isopropyl alcohol are 30.68 and 19.53, respectively. An addition of more amount of alcohol in to water causes the ϵ value of the mixture to decrease. At 30° C, the ϵ value for water + methanol solution is 72.37, while the ϵ value for water

+ isopropyl alcohol is 70.17. When composition of alcohol rose to 60% w/w, the ϵ values of water + methanol solution and water + isopropyl alcohol solution went down to 48.58 and 35.53, respectively. The decreasing of ϵ values in water + anti-solvent mixtures leads to increase of the number of electrostatic interactions between ions of opposite charge. This condition causes the ionic cohesion forces and precipitation will occur. Moreover, when the ϵ values is lower than 40, the formation of ionic pairs generally takes place in the entire solution (Pina *et al.*, 2001), so that the mannan precipitation increases.

The effect of anti-solvent types can also be analyzed from the fact that the addition of anti-solvent causes volume expansion of the organic solution and the reduction of solvent strength, from which subsequently precipitating the solute (Bothun *et al.*, 2002). The molar volume of water, methanol and isopropyl alcohol are 18.0, 40.7 and 76.9 cm³/mol, respectively (Babu *et al.*, 2007). It is clear that when added at the same amount, isopropyl alcohol gives larger volume expansion to water + mannan system compared to methanol. The total solubility parameter of water, methanol and isopropyl alcohol are 23.4, 14.5 and 11.5 (cal/cm³)^{1/2}, respectively (Babu *et al.*, 2007). In contrast to the volume expansion, the addition of methanol and isopropyl alcohol to the water + mannan system causes a reduction of the solvent strength as reflected by the decrease of total solubility parameter value. The solvent strength reduction was more pronounced when isopropyl alcohol was added due to its lower value of total solubility parameter. Therefore, it is plausible that mannan precipitation was higher in water + isopropyl alcohol system than in water + methanol system.

From the anti-solvent precipitation kinetic modeling, it was obtained that the order of the precipitation rate of mannan was very small, which was 0.0232 for both for methanol and isopropyl alcohol. For this reason, the order of the anti-solvent precipitation rate of mannan was then taken as zero. The precipitation rate constant (K_v) of mannan from water + methanol and water + isopropyl alcohol systems were 0.0109 and 0.0128 g/min, respectively. As a consequence, the mannan precipitation rates were then expressed as $R_\beta = K_v$, and the precipitation rate constant (K_v) of mannan from water + methanol and water + isopropyl alcohol systems were, 0.0109 and 0.0128 g/min, respectively. The values of SSE and ARD obtained in this work were 0.0096 and 12.98%, respectively for methanol and 0.0049 and 10.48%, respectively for isopropyl alcohol. The profile of mannan precipitation as function of anti-solvent type and anti-solvent addition time is shown in Figure 3. It is clearly shown in Figure 3 that the high intensity interactions between water + anti-solvent in the beginning stage of the system results in large volume expansions of the mannan-water solution system and the reduction of solvent strength, from which

subsequently rapidly precipitating mannan from the solution (Bhothun *et al.*, 2002).

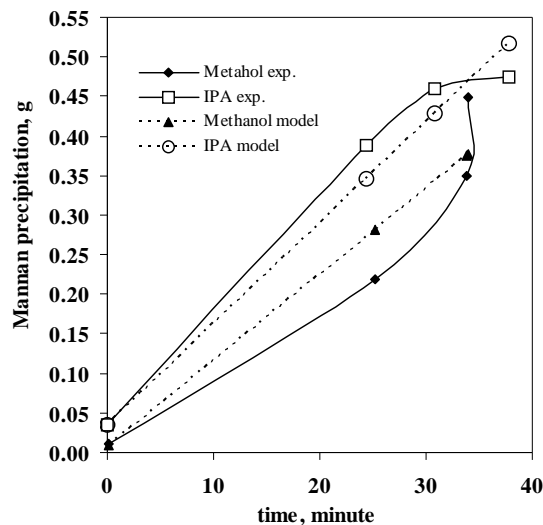

Figure 3. Relation between solvents addition time and the mannan precipitation

Further addition of anti-solvent by lengthening the precipitation process caused in a decrease in mannan precipitation rate. The large reduction of mannan concentration in the mannan-water solution after the rapid precipitation in the early stage of this process was likely to be the cause of the decrease in mannan precipitation rate (Bothun *et al.*, 2002). This phenomenon was more pronounced when isopropyl alcohol was added to the mannan-water system compared to methanol. The zero rate of mannan precipitation, means that the precipitation is not affected by the amount of mannan precipitated or mannan concentration in the *Aloe vera* leaf pulp juice solution. The precipitation was likely only caused by the molecular physical interaction between mannan and the mixed solvent (water + anti-solvent).

CONCLUSIONS

The results of this work revealed the fact that isopropyl alcohol was a more effective anti-solvent than methanol to precipitate mannan from *Aloe vera* leaf pulp juice. The proposed anti-solvent precipitation kinetics model represented the precipitation phenomena fairly well with average relative deviation of only 11.73%, and finally suggested that the system followed the zero order precipitation rates as $R_\beta = K_v$, where $K_v = 0.0109$ g/min for methanol and 0.0128 g/min for isopropyl alcohol.

REFERENCES

- Åkerlöf, G., (1932), Dielectric constants of some organic solvent-water mixtures at various temperatures, *J. Am. Chem. Soc.*, 54, pp. 4125-4139.
- Babu, P.R.S., Subrahmanyam, C.V.S., Thimmasetty, J., Manavalan, R., and Valliappan, K., (2007),

- Extended Hansen's Solubility Approach: Meloxicam In Individual Solvents, *Pak. J. Pharm. Sci.*, 20 (4), pp. 311-316.
- Bothun, G.D., White, K.L., and Knutson, B.L., (2002), Gas anti-solvent fractionation of semicrystalline and amorphous poly(lactic acid) using compressed CO₂, *Polym.*, 43, pp. 4445-4452.
- Boudreau, M.D. and Beland, F.A., (2006), An evaluation of the biological and toxicological properties of *Aloe Barbadosis* (Miller), *Aloe vera*, *J. Environ. Sci. Health C.*, 24, pp. 103-154.
- Eshun, K. and He, Q., (2004), Aloe vera: A valuable ingredient for the food, pharmaceutical and cosmetic industries – A review, *Crit. Rev. Food Sci. Nutr.*, 44, pp. 91-96.
- Femenia, A., Sanchez, E.S., Simal, S., and Rosello, C., (1999), Compositional features of polysaccharides from *Aloe vera* (*Aloe barbadensis* Miller) plant tissues, *Carbohydr. Polym.*, 39, pp. 109-117.
- Hamman, J.H., (2008), Composition and Applications of Aloe vera Leaf Gel, *Molecules*, 13, pp. 1599-1616.
- Hyung, W., Kim, Y., Haam, S., and Koo, K., (2006), Agglomeration behavior of anhydrous L-ornithine-L-aspartate crystals during Semi-batch drowning-out crystallization, *Korean J. Chem. Eng.*, 23(5), pp. 819-826.
- Mullin, J.W., (2001), *Crystallization*, Fourth Edition, Butterworth-Heinemann, A division of Reed Educational and Professional Publishing Ltd, Oxford, pp. 333-334.
- Ni, Y., Turner, D., Yates, K.M., and Tizard, I., (2004), Isolation and characterization of structural components of Aloe vera L leaf pulp, *Int. Immunopharmacol.*, 4, pp. 1745-1755.
- Nowee, S.M., Abbas, A., and Romagnoli, J.A., (2008), Antisolvent crystallization: Model identification, experimental validation and dynamic simulation, *Chem. Eng. Sci.*, 63, pp. 5457-5467
- Pina, C.M., Diaz, L.F., and Verdager, S.V., (2001), Metastability in drowning-out crystallisation: precipitation of highly soluble sulphates, *J. Crystal Growth*, 222, pp. 317-327.
- Schorger, A.W., (1917), The chemistry of wood: III. Mannan content on the gymnosperms, *J. Ind. Eng. Chem*, 9 (8), pp. 748-750.
- Takiyama, H., Otsuhata, T., and Matsuoka, M., (1998), Morphology of NaCl crystals in drowning-out precipitation operation, *Trans IchemE*, 76, pp. 809-814.
- Tóth, J., Fodor, A.K., and Péterfi, S.H., (2005), The formation of fine particles by salting-out precipitation, *Chem. Eng. Proc.*, 44, pp. 193-200.