

EXECUTIVE SUMMARY
TUGAS PERANCANGAN PABRIK KIMIA



**TUGAS PERANCANGAN PABRIK BIODIESEL DARI CRUDE
JATROPHA OIL DENGAN PROSES TRANSESTERIFIKASI**

Disusun oleh :

SUCI AMBARYANTI NIM L2C3 09 014
ADI KURNIADIN NIM L2C3 09 016

JURUSAN TEKNIK KIMIA FAKULTAS TEKNIK
UNIVERSITAS DIPONEGORO
SEMARANG

2011

EXECUTIVE SUMMARY

JUDUL TUGAS	PERANCANGAN PABRIK BIODIESEL DARI CRUDE JATROPHA OIL DENGAN PROSES TRANSESTERIFIKASI
	KAPASITAS 200.000 TON/TAHUN

I. STRATEGI PERANCANGAN

Latar Belakang	<p>Kehidupan manusia tidak pernah bisa lepas dari kebutuhan energi. Pertambahan jumlah penduduk yang disertai dengan peningkatan kesejahteraan masyarakat berdampak pada makin meningkatnya kebutuhan sarana transportasi dan aktivitas industri. Hal ini tentu saja menyebabkan kebutuhan bahan bakar cair terus meningkat. Tetapi produksi energi dalam negeri cenderung lebih rendah dibanding tingkat konsumsinya. Menurut data <i>automotive diesel oil</i>, konsumsi bahan bakar minyak diindonesia sejak tahun 1995 telah melebihi produksi dalam negeri.</p> <p>Kebutuhan energi masyarakat dan industri setiap tahun meningkat. Kondisi ini harus diakomodasi oleh pemerintah melalui penyediaan energi dalam jumlah yang mencukupi dan harganya harus terjangkau oleh masyarakat. Mengingat cadangan minyak bumi indonesia yang makin menipis, impor minyak bumi yang semakin tinggi dan kenaikan harga minyak bumi dunia yang dapat dipastikan akan diikuti oleh kenaikan BBM sehingga berdampak pada kenaikan harga kebutuhan pokok di masyarakat maka diperlukan pengembangan energi alternatif terbarukan.</p>
Penetapan Kapasitas Produksi	<p>produksi biodiesel Indonesia pada tahun 2009 sebesar 720.000 kiloliter dan target produksi pada tahun 2012 yaitu 937.125 kiloliter, maka penentuan kapasitas pra rancangan pabrik sebagai berikut :</p> $Pc = Md - Ms$ <p>Dimana :</p> <p>Pc : Pra rancangan pabrik Md : perkiraan kebutuhan biodiesel Ms : perkiraan total produksi biodiesel</p> <p>Jadi Pc = Md - Ms = 973.125 - 720.000 = 253.125 Kiloliter</p> <p>Maka kapasitas terhitung sebesar 222.497 Ton/tahun, sehingga kapasitas prarancangan pabrik 200.000 Ton/tahun.</p>
Pemilihan Lokasi	<p>Lokasi pendirian pabrik biodiesel akan didirikan di kupang Nusa Tenggara Timur. Didasarkan pada teori Klein Splenger, bahwa lokasi pabrik dipengaruhi oleh factor primer dan sekunder.</p> <p>1. Faktor primer</p> <ol style="list-style-type: none"> a. Dekat dengan bahan baku b. Dekat dengan pasar c. Transportasi Mudah d. Ketersediaan Tenaga Kerja

	<p>e. Utilitas</p> <p>2. Faktor Sekunder</p> <p>a. Harga Tanah</p> <p>b. Perpajakan</p> <p>c. Perizinan</p> <p>d. Masyarakat</p>
Bahan Baku dan Produk	<p>Bahan Baku</p> <p><i>Crude Jatropha Curcas (CJCO)</i></p> <p>Sifat fisik</p> <ul style="list-style-type: none"> - Fasa : Cair (30⁰C, 1 atm) - Specific gravity (25/25⁰C) : 0,9177 - Viskositas : 49,15 mm²/s - Flash point : 236⁰C - Pour point : - 2,5 ⁰C - Bilangan asam : 4.75 mg KOH/g - Bilangan iod : 96,5 gr iod/100 gr minyak - Kadar air : 935 ppm - Kadar sulfur : >1 ppm - Komposisi CJO : Trigliserida 97,27 %, FFA 2,7 % da gum 0,03 % - Komposisi asam lemak : <li style="margin-left: 20px;">a. Asam palmitat (C₁₆H₃₂O₂) : 15,18 % <li style="margin-left: 20px;">b. Asam oleat (C₁₈H₃₄O₂) : 40,53 % <li style="margin-left: 20px;">c. Asam linoleat (C₁₈H₃₂O₂) : 37,06 % <li style="margin-left: 20px;">d. Asam stearat (C₁₈H₃₆O₂) : 7,23 % (erliza, dkk. 2006) <p>Produk</p> <p>Biodiesel</p> <p>Sifat fisik</p> <ul style="list-style-type: none"> - Fasa : Cair (30⁰C, 1 atm) - Densitas : 0,879 (g/cm³, 20 ⁰C) - Viskositas : 4,20 (mm²/s, 40⁰C) - Bilangan setana (ISO 5165) : 57-62 - Nilai kalori : 37-38 Mj/kg - Residu karbon : 0,025 - Cloud points : 5 ⁰C - Heating value : 15.700 btu/lb-16735 btu/lb - Emission type : <li style="margin-left: 20px;">- Total unburned hydrocarbon : 93% <li style="margin-left: 20px;">- Carbon monoxide : 50% <li style="margin-left: 20px;">- Particular matter : 30% <li style="margin-left: 20px;">- Heat combustion : 39,8 MJ/kg <li style="margin-left: 20px;">- Pour point : -1 ⁰C <li style="margin-left: 20px;">- Boiling point : 200 ⁰C pada 760 mmHG <li style="margin-left: 20px;">- Bilangan iod : 95-106 <li style="margin-left: 20px;">- Kandungan sulfur : <50 ppm

II. DIAGRAM ALIR PROSES DAN PENERACAAN

PRA RANCANG PABRIK BIODIESEL DARI JATROPA OIL KAPASITAS 200.000 TON/TAHUN

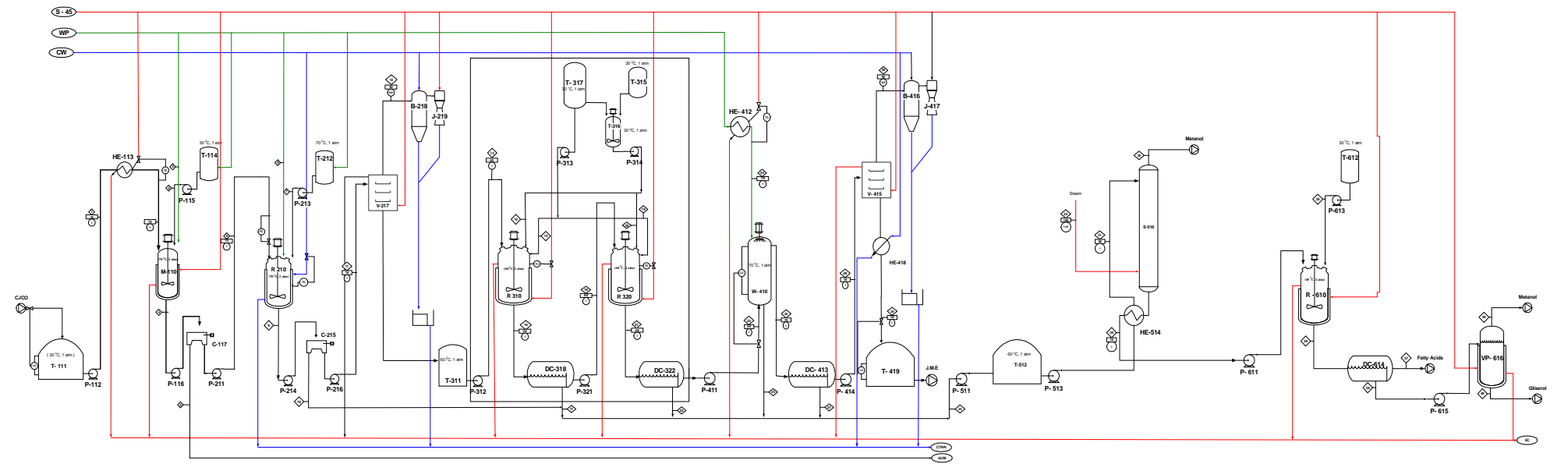

BMH(KgHR)	1	2	3	4	5	6	7	8	9	10	11	12	13	14	15	16	17	18	19	20	21	22	23	24	25	26	27	28	29	30	31	32	33	34	35	36	37	38	39	40			
Trigliseras	24803,85			24803,85		24803,85			2455,81		2455,81		2455,81		2455,81		2455,81		2455,81		2455,81		2455,81		2455,81		2455,81		2455,81		2455,81		2455,81		2455,81		2455,81		2455,81		2455,81		
GLM	7,85			7,85	7,85																																						
FFA	68,30			68,5	68,5	68,5			6,8		6,8		6,8																														
Miny Elar																																											
Melard																																											
NCH																																											
Air																																											
Oksid																																											
Stackack																																											
Ketils																																											
HD																																											
H ₂ O ₂																																											
Stem																																											
NO																																											
Total	2500	2,5	5,74	2531,24	726,36	2540,38	131,1	3524,01	2945,25	489,19	2459,05	2,35	2432,7	5420,5	594,8	3050,32	482,76	3050,32	542	542,6	2643,77	1934,4	2643,74	4894,2	4893,6	2525,76	520,8	2482,01	24,2	2407,85	17593,9	5701	7040,4	4813,9	981,9	389,66	2454	287,11	231,3	342,4			

III. PERALATAN PROSES DAN UTILITAS

Spesifikasi Alat Utama	<p>3.1 Tangki Penyimpanan Minyak Jarak (T-111) Fungsi : menyimpan bahan baku Minyak Jarak cair selama 15 hari Tipe : Silinder tegak dengan dasar datar (flat bottom) dan atapnya berbentuk kerucut (conical). Jumlah : 1 buah Kapasitas : 14.976,17 bbl Bahan : Carbon Steel SA-7 Tekanan : 1,5 atm Suhu : 30 °C</p> <p>3.2 Heater degumming (HE-113) Fungsi : Memanaskan minyak sebelum ke degumming sampai suhu masuk 70 °C Kapasitas : 697.036,7 Btu/jam Jenis : sheel and tube 1-2 Jumlah : 1 buah ➤ Bagian tube OD,BWG,pitch : 1 in, 16, 1 ¼ in² L = 16 ft ID = 0,87 in n = 2 at' = 0,594 in² P_T = 1,25 in a'' = 0,2618 ft²/ft ➤ Bagian shell De = 0,99 in n' = 1 IDs = 13 ¼ in C' = ¼ in</p> <p>3.3 Pompa (P-311) Fungsi : Memompa bahan baku minyak jarak dari tangki penyimpan (T-219) menuju reaktor transesterifikasi (R-310) Tipe : Pompa centrifugal Kapasitas : 8,767.34 Kg/jam Power pompa : 2 Hp Bahan konstruksi : Comersial steel Head : 37,216 ft Ukuran pipa : 2 in schedule 80 Diameter Pipa bagian dalam : 0,20575 ft Power motor penggerak : 1,5 hp</p> <p>3.4 Reaktor Transesterifikasi I (R-310) Fungsi : Mereaksikan trigliserida dengan metanol dengan bantuan katalis sodium methoxide Tipe : CSTR (<i>Continuous Stirred Tank Reaktor</i>) Kondisi Operasi : Tekanan : 1 atm Suhu operasi : 60 °C Jumlah : 1 Unit Bentuk : Silinder vertical dengan tutup dan dasar Volume tangki : 373,456 ft³ Volume Liquid : 248,97 ft³ Diameter Tangki : 7,8062 ft = 2,379 m Tinggi Tangki : 7,8062 ft = 2,379 m Tinggi Liquid : 5,205 ft = 1,586 m Shell</p>
---------------------------	--------------------------------------------------------------------------------------------------------------------------------------------------------------------------------------------------------------------------------------------------------------------------------------------------------------------------------------------------------------------------------------------------------------------------------------------------------------------------------------------------------------------------------------------------------------------------------------------------------------------------------------------------------------------------------------------------------------------------------------------------------------------------------------------------------------------------------------------------------------------------------------------------------------------------------------------------------------------------------------------------------------------------------------------------------------------------------------------------------------------------------------------------------------------------------------------------------------------------------------------------------------------------------------------------------------------------------------------------------------------------------------------------------------------------------------------------------------------------------------------------------------------------------------------------------------------------------------------------------------------------------------------------------------------------------------------------------------------------------------------------------------------------------------------------------------------------------------------------------------------------------------------------------------------------------------------------------------------------------------------------

1. ID : 93,6741 in = 7,806 ft
2. Tebal : ¼ in
3. OD : 94,17 in
4. Bahan : Stainless Steels SA-240 Grade D
5. Welded : Double Welded Butt Joint

Flanged & dishead Head

1. ID : 119,50 in
2. Tebal : 5/16 in
3. OD : 120 in
4. Bahan : Stainless Steels SA-240 Grade D
5. Welded : Double Welded Butt Joint
6. Icr : 7 5/8 in
7. r : 114 in
8. a : 59,75 in
9. AB : 52,125 in
10. BC : 106,375 in
11. AC : 92,73 in
12. b : 21,27 in
13. OA : 24,7087 in

Spesifikasi Pengaduk

1. Tipe : propeller
2. Jumlah : 1 buah
3. Diameter : 36 in
4. Putaran : 300 rpm
5. Motor Power : 40 hp

Spesifikasi Jacket

- Tebal Jacket : ¼ in

3.5 Decanter (DC-318)

Fungsi = Untuk memisahkan crude biodiesel dengan gliserol
Tipe = Horizontal cylindrical continuous decanter
Debit input = 37.119,897 kg/hari = 38.562 lit/hari = 424,49 gal/jam
Kondisi operasi = Tekanan = 1 atm
Suhu = 60 °C
Diameter luar = 48 in = 1,2192 m
Tebal shell = ¼ in
Tinggi liquid total = 3,5719 ft = 1,0887 m
Tinggi interface = 1,786 ft = 0,5444 m
Tinggi liquid berat = 3,293 ft = 1,0038 m
Bahan konstruksi = Sa-240 Grade A
Tipe rotor = Solid bowl
Kapasitas alat = 54.000 gal/jam
Jarak stream output dari ujung decanter = 2 mm (range 0,4-3 mm)
Jumlah tangki = 1 buah

3.6 Wash Column (W-320)

Fungsi = Mencuci sekaligus memisahkan gliserin sebagai produk samping dari produk utama biodiesel dengan penambahan air hangat
Tipe = Silinder tegak dengan tutup atas dan bawah berbentuk standar dished heads
Kondisi operasi = Tekanan = 1 atm
Suhu = 48,078 °C
Dimeter luar = 66 in = 1,6764 m

	<p>Tebal shell = 3/16 in Tebal tutup atas = 1/4 in Tebal tutup bawah = 1/4 in Tinggi tangki = 124,0651 in = 3,1513 m Bahan konstruksi = Stainless steel SA-167 Grade 3 tipe 304 Jumlah tangki = 1</p>
Utilitas	<p>➤ <i>Kebutuhan Air</i></p> <p>a. Kebutuhan Air untuk Proses Kebutuhan air proses adalah sekitar 10.140,33 kg. Air yang digunakan pendingin sebanyak 2.486.937,25 Kg. Diperkirakan air yang digunakan pendingin akan hilang sekitar 20 %. Jadi make-up air sebanyak 497.387,45 kg. Jadi total kebutuhan air untuk proses adalah 2.994.465,03 kg.</p> <p>b. Kebutuhan air untuk steam Kebutuhan air untuk steam adalah sekitar 2.004.731,99 kg. Diperkirakan air yang hilang sebanyak 5 %, sehingga kebutuhan make-up air untuk steam sebanyak 200.473,20 kg. Total kebutuhan air untuk steam adalah 2.205.205,19 kg.</p> <p>c. Kebutuhan Air untuk Perkantoran dan Laboratorium Kebutuhan air untuk perkantoran dan laboratorium dapat diperkirakan adalah 81,8 m³/hari</p> <p>➤ <i>Unit Pengadaan Steam</i></p> <ul style="list-style-type: none"> • Kebutuhan steam Dari data diketahui bahwa total kebutuhan air untuk steam = 2.205.205,19 Kg/jam Kebutuhan steam ini dipenuhi dari 1 unit boiler. Jenis boiler merupakan <i>water tube boiler</i>. Kebutuhan air untuk pembuatan steam dipenuhi dari unit pengolahan air demineralisasi (<i>demin water tank</i>) dan dari kondensat yang dikembalikan ke <i>deaerator</i>. <p>➤ <i>Unit Pembangkit Tenaga Listrik</i></p> <ul style="list-style-type: none"> • Kebutuhan listrik kebutuhan listrik untuk keperluan proses = 815,44 Hp Total power yang dibutuhkan = 815,44 Hp × 0,746 kW/HP = 608,32 kW <p>➤ <i>Unit Pengadaan Bahan Bakar</i> Untuk menjalankan generator digunakan bahan bakar solar dan minyak residu digunakan untuk bahan bakar boiler.</p> <p>A. Solar</p> <ul style="list-style-type: none"> • Kebutuhan solar = $57.809.365,12 / (0,8 \times 0,8691 \times 19.440)$ = 4.277,29 lb/jam = 78,83 ft³/jam <p>B. Minyak residu</p> <ul style="list-style-type: none"> • Kebutuhan = 4693,355 lb/jam = 79,360³/jam

IV. PERHITUNGAN EKONOMI

<p><i>Capital Investment</i></p>	<ul style="list-style-type: none"> • <i>Physical Plant Cost</i> <table border="1" style="width: 100%; border-collapse: collapse;"> <thead> <tr> <th style="text-align: left;">Jenis PPC</th> <th style="text-align: right;">Biaya (US\$)</th> </tr> </thead> <tbody> <tr><td>Purchased Equipment cost</td><td style="text-align: right;">7,697,114.04</td></tr> <tr><td>Equipment installation cost</td><td style="text-align: right;">3,309,759.04</td></tr> <tr><td>Piping cost</td><td style="text-align: right;">6,619,518.07</td></tr> <tr><td>Instrumentation cost</td><td style="text-align: right;">2,309,134.21</td></tr> <tr><td>Insulation cost</td><td style="text-align: right;">615,769,12</td></tr> <tr><td>Electrical cost</td><td style="text-align: right;">769,711.40</td></tr> <tr><td>Building, process & Auxiliary Cost</td><td style="text-align: right;">968,992.25</td></tr> <tr><td>Land and Yard Improvement cost</td><td style="text-align: right;">4,123,062.02</td></tr> <tr><td>Utilities Cost</td><td style="text-align: right;">769,711,40</td></tr> <tr><td>Environment Cost</td><td style="text-align: right;">4,402,749.23</td></tr> <tr><td>Total PPC</td><td style="text-align: right;">31,585,520.79</td></tr> <tr><td></td><td style="text-align: right;">Rp. 325,962,574,545</td></tr> </tbody> </table> • <i>Fixed Capital Investment</i> <table border="1" style="width: 100%; border-collapse: collapse;"> <thead> <tr> <th style="text-align: left;">Jenis FCI</th> <th style="text-align: right;">US\$</th> </tr> </thead> <tbody> <tr><td><i>Direct Plant Cost (DPC)</i></td><td style="text-align: right;">37,902,624.95</td></tr> <tr><td><i>Contractor's fee cost</i></td><td style="text-align: right;">1,895,131.25</td></tr> <tr><td><i>Contingency cost</i></td><td style="text-align: right;">5.285.352,91</td></tr> <tr><td>Total FCI</td><td style="text-align: right;">45,483,149.94</td></tr> </tbody> </table> • <i>Working Capital</i> <table border="1" style="width: 100%; border-collapse: collapse;"> <thead> <tr> <th style="text-align: left;">Working Capital</th> <th style="text-align: right;">Biaya (US\$)</th> </tr> </thead> <tbody> <tr><td>Raw Material Inventory</td><td style="text-align: right;">1.154.445</td></tr> <tr><td>In Process Inventory</td><td style="text-align: right;">8.154</td></tr> <tr><td>Product Inventory</td><td style="text-align: right;">3.913.685</td></tr> <tr><td>Available Cash</td><td style="text-align: right;">7.827.369</td></tr> <tr><td>Extended Credit</td><td style="text-align: right;">9.786.485</td></tr> <tr><td>Total</td><td style="text-align: right;">26.603.821,9</td></tr> </tbody> </table> • <i>Total Capital Investment</i> <table border="1" style="width: 100%; border-collapse: collapse;"> <thead> <tr> <th style="text-align: left;">Capital Investment</th> <th style="text-align: right;">Biaya</th> </tr> </thead> <tbody> <tr><td><i>Fixed Capital Investment</i></td><td style="text-align: right;">45,483,149.94</td></tr> <tr><td><i>Working Capital Investment</i></td><td style="text-align: right;">26.603.821,9</td></tr> <tr><td><i>Plant Start-Up</i></td><td style="text-align: right;">4,093,483.49</td></tr> <tr><td>Total Capital Investment</td><td style="text-align: right;">71.593.725,9</td></tr> </tbody> </table> 	Jenis PPC	Biaya (US\$)	Purchased Equipment cost	7,697,114.04	Equipment installation cost	3,309,759.04	Piping cost	6,619,518.07	Instrumentation cost	2,309,134.21	Insulation cost	615,769,12	Electrical cost	769,711.40	Building, process & Auxiliary Cost	968,992.25	Land and Yard Improvement cost	4,123,062.02	Utilities Cost	769,711,40	Environment Cost	4,402,749.23	Total PPC	31,585,520.79		Rp. 325,962,574,545	Jenis FCI	US\$	<i>Direct Plant Cost (DPC)</i>	37,902,624.95	<i>Contractor's fee cost</i>	1,895,131.25	<i>Contingency cost</i>	5.285.352,91	Total FCI	45,483,149.94	Working Capital	Biaya (US\$)	Raw Material Inventory	1.154.445	In Process Inventory	8.154	Product Inventory	3.913.685	Available Cash	7.827.369	Extended Credit	9.786.485	Total	26.603.821,9	Capital Investment	Biaya	<i>Fixed Capital Investment</i>	45,483,149.94	<i>Working Capital Investment</i>	26.603.821,9	<i>Plant Start-Up</i>	4,093,483.49	Total Capital Investment	71.593.725,9
Jenis PPC	Biaya (US\$)																																																												
Purchased Equipment cost	7,697,114.04																																																												
Equipment installation cost	3,309,759.04																																																												
Piping cost	6,619,518.07																																																												
Instrumentation cost	2,309,134.21																																																												
Insulation cost	615,769,12																																																												
Electrical cost	769,711.40																																																												
Building, process & Auxiliary Cost	968,992.25																																																												
Land and Yard Improvement cost	4,123,062.02																																																												
Utilities Cost	769,711,40																																																												
Environment Cost	4,402,749.23																																																												
Total PPC	31,585,520.79																																																												
	Rp. 325,962,574,545																																																												
Jenis FCI	US\$																																																												
<i>Direct Plant Cost (DPC)</i>	37,902,624.95																																																												
<i>Contractor's fee cost</i>	1,895,131.25																																																												
<i>Contingency cost</i>	5.285.352,91																																																												
Total FCI	45,483,149.94																																																												
Working Capital	Biaya (US\$)																																																												
Raw Material Inventory	1.154.445																																																												
In Process Inventory	8.154																																																												
Product Inventory	3.913.685																																																												
Available Cash	7.827.369																																																												
Extended Credit	9.786.485																																																												
Total	26.603.821,9																																																												
Capital Investment	Biaya																																																												
<i>Fixed Capital Investment</i>	45,483,149.94																																																												
<i>Working Capital Investment</i>	26.603.821,9																																																												
<i>Plant Start-Up</i>	4,093,483.49																																																												
Total Capital Investment	71.593.725,9																																																												
<p>Analisis Kelayakan</p>	<p>a. Keuntungan (Profit)</p> <p>Keuntungan Sebelum Pajak = US\$ 9,990,472,14 = Rp. 103.101.672.450,63</p> <p>Keuntungan Setelah Pajak = Rp. 72.188.670.715,44 = US\$ 6.995.026,23</p>																																																												

	b. Return On Investment (ROI) ROI Sebelum Pajak = 21,97 % ROI Setelah Pajak = 15,38 %
	c. Pay Out Time (POT) POT Sebelum Pajak = 3,13 Tahun POT Setelah Pajak = 3,94 Tahun
	d. Break Even Point (BEP) <i>Break Even Point (BEP) yang diperoleh adalah 51,30 %</i>
	e. Shut Down Point (SDP) <i>Shut Down Point (SDP) yang peroleh adalah 25,80 %</i>