

BAB IV

RENCANA KONSTRUKSI
(PROFILE CONSTRUCTION)

Perhitungan profile construction (rencana konstruksi) berdasarkan ketentuan BKI (Biro Klasifikasi Indonesia) Th. 2006 Volume II.

A. PERKIRAAN BEBAN

A.1 Beban geladak cuaca (Load and Weather Deck)

Yang dianggap sebagai geladak cuaca adalah semua geladak yang bebas kecuali bangunan atas yang tidak efektif yang terletak di belakang 0,5L dari garis tengah.

$$P_D = P_o \frac{20T}{(10+Z-T) \times H} \times c_D \quad [\text{KN/m}^2]$$

(Ref : BKI Th. 2006 Vol. II Sec. 4 B.1.1)

Dimana :

P_o = Basis Eksternal dinamic Load

$P_o = 2,1 \times (C_b + 0,7) \times C_o \times C_L \times f \times C_{RW} \quad \text{KN/m}^2$

$c_D = 1$ untuk $L > 50$

$C_b =$ koefisien block 0,68

$C_o = 10,75 - \left(\frac{300 - L}{100} \right)^{1,5}$ for $90 \leq L \leq 300 \text{ M}$

$$= 10,75 - \left(\frac{300 - 98,68}{100} \right)^{1,5}$$

$$= 7,89$$

$C_L = 1,0$ for $L \geq 90 \text{ M}$

$f_1 = 1,0$ Untuk tebal plat Geladak Cuaca

$f_2 = 0,75$ Untuk Main Frame, Stiffener, dan Deck Beam

$f_3 = 0,6$ Untuk SG, CG, CDG, Web Frame, Stringers, Grillage

$C_{rw} = 0,9$ untuk pelayaran nasional

(Ref : BKI Th. 2006 Vol. II Sec. 4.A.2.2)

PROFILE CONSTRUCTION

TUGAS AKHIR KM "BAHARI JAYA" GC 3805 BRT

Jadi :

untuk plat Geladak Cuaca (Po_1)

$$\begin{aligned}Po_1 &= 2,1 \times (Cb + 0,7) \times Co \times C_L \times f_1 \times C_{rw} \\ &= 2,1 \times (0,68 + 0,7) \times 7,89 \times 1,0 \times 1,0 \times 0,9 \\ &= 22,88 \text{ KN/m}^2\end{aligned}$$

untuk Main Frame, Deck Beam (Po_2)

$$\begin{aligned}Po_2 &= 2,1 \times (Cb + 0,7) \times Co \times C_L \times f_2 \times C_{rw} \\ &= 2,1 \times (0,68 + 0,7) \times 7,89 \times 1,0 \times 0,75 \times 0,9 \\ &= 17,16 \text{ KN/m}^2\end{aligned}$$

untuk Web Frame, Strong Beam, Girder, Stringer, dan Grillage (Po_3)

$$\begin{aligned}Po_3 &= 2,1 \times (Cb + 0,7) \times Co \times C_L \times f_3 \times C_{rw} \\ &= 2,1 \times (0,68 + 0,7) \times 7,89 \times 1,0 \times 0,6 \times 0,9 \\ &= 13,73 \text{ KN/m}^2\end{aligned}$$

Z = jarak vertikal dari pusat beban ke base line

$$\begin{aligned}Z &= H \\ &= 8,81 \text{ m}\end{aligned}$$

C_D = faktor penambahan / pengurangan untuk daerah

$$\begin{aligned}C_{D1} &= 1,2 - X/L \quad \left(\text{untuk } 0 \leq \frac{X}{L} \leq 0,2 ; \text{buritan kapal}\right) \\ &= 1,2 - 0,1 \\ &= 1,1\end{aligned}$$

$$C_{D2} = 1,0 \quad \left(\text{untuk } 0,2 \leq \frac{X}{L} \leq 0,7 ; \text{tengah kapal}\right)$$

$$\begin{aligned}C_{D3} &= 1,0 + \frac{C}{3} \left\{ \frac{X}{L} - 0,7 \right\} \quad \left(\text{untuk } 0,7 \leq \frac{X}{L} \leq 1,0 ; \text{haluan kapal}\right) \\ &= 1,0 + \frac{5}{3} (0,93 - 0,7) \\ &= 1,383\end{aligned}$$

Dimana :

Nilai C : $0,15 L - 10$

Apabila L min = 100 M

Lmax = 200 M

PROFILE CONSTRUCTION

TUGAS AKHIR KM "BAHARI JAYA" GC 3805 BRT

Diambil 100 M

$$\begin{aligned} C &= (0,15 \times 100) - 10 \\ &= 5 \end{aligned}$$

(Ref : BKI Th. 2006 Vol. II Sec. 4 Tabel. 4.1)

a. Beban Geladak Cuaca untuk menghitung plat Geladak

1) Pada daerah buritan

$$\begin{aligned} P_{D1} &= P_{o1} \frac{20T}{(10+Z-T) \times H} \times C_{D1} \\ &= 22,88 \times \frac{20 \times 7,15}{[10 + 8,81 - 7,15] \times 8,81} \times 1,1 \\ &= 35,03 \text{ KN/m}^2 \end{aligned}$$

2) Pada daerah midship

$$\begin{aligned} P_{D2} &= P_{o1} \frac{20T}{(10+Z-T) \times H} \times C_{D2} \\ &= 22,88 \times \frac{20 \times 7,15}{[10 + 8,81 - 7,15] \times 8,81} \times 1,0 \\ &= 31,84 \text{ KN/m}^2 \end{aligned}$$

3) Pada daerah Haluan

$$\begin{aligned} P_{D3} &= P_{o1} \frac{20T}{(10+Z-T) \times H} \times C_{D3} \\ &= 22,88 \times \frac{20 \times 7,15}{[10 + 8,81 - 7,15] \times 8,81} \times 1,383 \\ &= 44,05 \text{ KN/m}^2 \end{aligned}$$

b. Beban Geladak untuk menghitung Deck Beam, Main frame, Stiffener

1) Pada daerah buritan

$$\begin{aligned} P_{D1} &= P_{o2} \frac{20T}{(10+Z-T) \times H} \times C_{D1} \\ &= 17,16 \times \frac{20 \times 7,15}{[10 + 8,81 - 7,15] \times 8,81} \times 1,1 \end{aligned}$$

PROFILE CONSTRUCTION

TUGAS AKHIR KM "BAHARI JAYA" GC 3805 BRT

$$= 26,27 \text{ KN/m}^2$$

2) Pada daerah Midship kapal

$$\begin{aligned} P_{D2} &= P_{o2} \frac{20T}{(10+Z-T) \times H} \times C_{D2} \\ &= 17,16 \times \frac{20 \times 7,15}{[10 + 8,81 - 7,15] \times 8,81} \times 1,0 \\ &= 23,88 \text{ KN/m}^2 \end{aligned}$$

3) Pada daerah Haluan kapal

$$\begin{aligned} P_{D3} &= P_{o2} \frac{20T}{(10+Z-T) \times H} \times C_{D3} \\ &= 17,16 \times \frac{20 \times 7,15}{[10 + 8,81 - 7,15] \times 8,81} \times 1,383 \\ &= 33,04 \text{ KN/m}^2 \end{aligned}$$

c. Beban Geladak untuk menghitung CDG, SDG dan SG

1) Pada daerah buritan

$$\begin{aligned} P_{D1} &= P_{o3} \frac{20T}{(10+Z-T) \times H} \times C_{D1} \\ &= 13,73 \times \frac{20 \times 7,15}{[10 + 8,81 - 7,15] \times 8,81} \times 1,1 \\ &= 21,02 \text{ KN/m}^2 \end{aligned}$$

2) Pada daerah Midship kapal

$$\begin{aligned} P_{D2} &= P_{o3} \frac{20T}{(10+Z-T) \times H} \times C_{D2} \\ &= 13,73 \times \frac{20 \times 7,15}{[10 + 8,81 - 7,15] \times 8,81} \times 1,0 \\ &= 19,11 \text{ KN/m}^2 \end{aligned}$$

3) Pada daerah Haluan kapal

$$\begin{aligned} P_{D3} &= P_{o3} \frac{20T}{(10+Z-T) \times H} \times C_{D3} \\ &= 13,37 \times \frac{20 \times 7,15}{[10 + 8,81 - 7,15] \times 8,81} \times 1,383 \\ &= 26,43 \text{ KN/m}^2 \end{aligned}$$

A.2 Beban Geladak pada bangunan atas (Superstructures Decks) dan rumah geladak (Deck Houses)

Beban Geladak pada bangunan atas dan rumah geladak dihitung berdasarkan formula sebagai berikut :

$$P_{DA} = P_D \times n \quad [\text{KN/m}^2]$$

(Ref : BKI Th. 2006 Vol. II Sec.4. B.5.1)

Dimana :

P_{DA} = Beban geladak pada buritan

$$n = \left[1 - \frac{Z - H}{10} \right] \quad Z = H + h$$

$n = 0,78$ untuk Forecastle Deck

$n_{min} = 0,5$

$h_1, h_2, h_3 = 2,2 \text{ m}$

$H = 8,81 \text{ m}$

Nilai “Z” bangunan atas & rumah geladak untuk beban geladak :

1. $Z_1 = H + 2,2 = 11,01 \text{ m}$ (Poop Deck)
2. $Z_2 = Z_1 + 2,2 = 13,21 \text{ m}$ (Boat Deck)
3. $Z_3 = Z_2 + 2,2 = 15,41 \text{ m}$ (Navigation Deck)
4. $Z_4 = Z_3 + 2,2 = 17,61 \text{ m}$ (Compass Deck)
5. $Z_5 = H + 2,2 = 11,01 \text{ m}$ (Forecastle Deck)

a. Beban geladak bangunan atas pada Geladak Kimbul [poop deck]

$$Z_1 = 11,01 \text{ m}$$

$$n = \left[1 - \frac{11,01 - 8,81}{10} \right]$$

$$= 0,78$$

$$P_{D1} = 35,03 \text{ KN/m}^2$$

$$P_{D1} = 26,27 \text{ KN/m}^2$$

$$P_{D1} = 21,02 \text{ KN/m}^2$$

1) Untuk menghitung plat geladak.

$$\begin{aligned}P_{DA} &= 35,03 \times 0,78 \\ &= 27,322 \text{ KN/m}^2\end{aligned}$$

2) Untuk menghitung deck beam.

$$\begin{aligned}P_{DA} &= 26,27 \times 0,78 \\ &= 20,492 \text{ KN/m}^2\end{aligned}$$

3) Untuk menghitung CDG, SDG dan strong beam.

$$\begin{aligned}P_{DA} &= 21,02 \times 0,78 \\ &= 16,393 \text{ KN/m}^2\end{aligned}$$

b. Beban geladak rumah geladak pada Geladak Sekoci [boat deck]

$$Z_2 = 13,21 \text{ m}$$

$$\begin{aligned}n &= \left[1 - \frac{13,21 - 8,81}{10} \right] \\ &= 0,56\end{aligned}$$

$$P_{D1} = 35,03 \text{ KN/m}^2$$

$$P_{D1} = 26,27 \text{ KN/m}^2$$

$$P_{D1} = 21,02 \text{ KN/m}^2$$

1) Untuk menghitung plat geladak.

$$\begin{aligned}P_{DA} &= 35,03 \times 0,56 \\ &= 19,616 \text{ KN/m}^2\end{aligned}$$

2) Untuk menghitung deck beam.

$$\begin{aligned}P_{DA} &= 26,27 \times 0,56 \\ &= 14,712 \text{ KN/m}^2\end{aligned}$$

3) Untuk menghitung CDG, SDG dan strong beam.

$$\begin{aligned}P_{DA} &= 21,02 \times 0,56 \\ &= 11,77 \text{ KN/m}^2\end{aligned}$$

**c. Beban geladak rumah geladak pada Geladak Kemudi
[Navigation deck]**

$$Z_3 = 15,41 \text{ m}$$

$$n = \left[1 - \frac{15,41 - 8,81}{10} \right]$$

$$= 0,34 \approx n_{\min} = 0,5$$

$$P_{D1} = 35,03 \text{ KN/m}^2$$

$$P_{D1} = 26,27 \text{ KN/m}^2$$

$$P_{D1} = 27,02 \text{ KN/m}^2$$

1) Untuk menghitung plat geladak.

$$\begin{aligned} P_{DA} &= 35,03 \times 0,5 \\ &= 17,514 \text{ KN/m}^2 \end{aligned}$$

2) Untuk menghitung deck beam.

$$\begin{aligned} P_{DA} &= 26,27 \times 0,5 \\ &= 13,136 \text{ KN/m}^2 \end{aligned}$$

3) Untuk menghitung CDG, SDG dan strong beam.

$$\begin{aligned} P_{DA} &= 21,02 \times 0,5 \\ &= 10,509 \text{ KN/m}^2 \end{aligned}$$

d. Beban geladak rumah geladak pada geladak kompas [Compass deck]

$$Z_4 = 17,61 \text{ m}$$

$$n = \left[1 - \frac{17,61 - 8,81}{10} \right]$$

$$= 0,12 \approx n_{\min} = 0,5$$

$$P_{D1} = 35,03 \text{ KN/m}^2$$

$$P_{D1} = 26,27 \text{ KN/m}^2$$

$$P_{D1} = 21,02 \text{ KN/m}^2$$

1) Untuk menghitung plat geladak.

$$\begin{aligned} P_{DA} &= 35,03 \times 0,5 \\ &= 17,514 \text{ KN/m}^2 \end{aligned}$$

2) Untuk menghitung deck beam.

$$\begin{aligned}P_{DA} &= 26,27 \times 0,5 \\ &= 13,136 \text{ KN/m}^2\end{aligned}$$

3) Untuk menghitung CDG, SDG dan strong beam.

$$\begin{aligned}P_{DA} &= 21,02 \times 0,5 \\ &= 10,509 \text{ KN/m}^2\end{aligned}$$

e. Beban geladak bangunan atas pada Geladak Akil [Fore Castle deck]

$$n = 1$$

$$P_{D3} = 44,05 \text{ KN/m}^2$$

$$P_{D3} = 33,04 \text{ KN/m}^2$$

$$P_{D3} = 26,43 \text{ KN/m}^2$$

1) Untuk menghitung plat geladak.

$$\begin{aligned}P_{DA} &= 44,05 \times 1,0 \\ &= 44,05 \text{ KN/m}^2\end{aligned}$$

2) Untuk menghitung deck beam.

$$\begin{aligned}P_{DA} &= 33,04 \times 1,0 \\ &= 33,04 \text{ KN/m}^2\end{aligned}$$

3) Untuk menghitung CDG, SDG dan strong beam.

$$\begin{aligned}P_{DA} &= 26,43 \times 1,0 \\ &= 26,43 \text{ KN/m}^2\end{aligned}$$

f. Beban geladak rumah geladak pada Geladak Derek [Winch deck]

$$Z_5 = Z_1 = 11,01 \text{ m}$$

$$n = \left[1 - \frac{11,01 - 8,81}{10} \right]$$

$$= 0,78$$

$$P_{D2} = 31,84 \text{ KN/m}^2$$

$$P_{D2} = 23,88 \text{ KN/m}^2$$

$$P_{D2} = 19,11 \text{ KN/m}^2$$

1) Untuk menghitung plat geladak.

$$\begin{aligned} P_{DA} &= 31,84 \times 0,78 \\ &= 24,839 \text{ KN/m}^2 \end{aligned}$$

2) Untuk menghitung deck beam.

$$\begin{aligned} P_{DA} &= 23,88 \times 0,78 \\ &= 18,629 \text{ KN/m}^2 \end{aligned}$$

3) Untuk menghitung CDG, SDG dan strong beam.

$$\begin{aligned} P_{DA} &= 19,11 \times 0,78 \\ &= 14,903 \text{ KN/m}^2 \end{aligned}$$

A.3 Beban sisi kapal

a. Beban sisi kapal dibawah garis air muat tidak boleh kurang dari rumus sebagai berikut :

$$P_s = 10 \times (T - Z) + P_o \times C_F \left(1 + \frac{Z}{T}\right) \text{ KN/m}^2$$

(Ref : BKI Th. 2006 Vol. II Sec.4. B.2.1.1)

Dimana :

$$P_{O1} = 22,88 \text{ KN/m}^2 \text{ (untuk plat geladak dan geladak cuaca)}$$

$$P_{O2} = 17,16 \text{ KN/m}^2 \text{ (untuk stiffener, main frame, deck beam)}$$

$$P_{O3} = 13,73 \text{ KN/m}^2 \text{ (untuk web, stringer, girder)}$$

z = Jarak tengah antara pusat beban ke base line

$$= \frac{1}{3} \times T = \frac{1}{3} \times 7,15$$

$$= 2,38 \text{ m}$$

$$CF_1 = 1,0 + \frac{5}{Cb} \left[0,2 - \frac{X}{L}\right] \text{ (buritan kapal)}$$

$$= 1,0 + \frac{5}{0,68} [0,2 - 0,1]$$

$$= 1,735$$

$$CF_2 = 1,0 \text{ untuk } 0,2 \leq \frac{X}{L} \leq 0,7 \text{ (tengah kapal)}$$

$$\begin{aligned}
 CF_3 &= 1,0 + \frac{20}{Cb} \left[\frac{X}{L} - 0,7 \right]^2 \quad (\text{haluan kapal}) \\
 &= 1,0 + \frac{20}{0,68} [0,93 - 0,7]^2 \\
 &= 2,556
 \end{aligned}$$

1) Beban sisi kapal di bawah garis air muat untuk pelat sisi

a) Untuk buritan kapal

$$\begin{aligned}
 Ps_1 &= 10 \times (T - Z) + Po_1 \times C_{F1} \left(1 + \frac{Z}{T} \right) \\
 &= 10 (7,15 - 2,38) + 22,88 \times 1,735 \left[1 + \frac{2,38}{7,15} \right] \\
 &= 100,59 \text{ KN/m}^2
 \end{aligned}$$

b) Untuk midship kapal

$$\begin{aligned}
 Ps_2 &= 10 \times (T - Z) + Po_1 \times C_{F2} \left(1 + \frac{Z}{T} \right) \\
 &= 10 (7,15 - 2,38) + 22,88 \times 1,0 \left[1 + \frac{2,38}{7,15} \right] \\
 &= 78,17 \text{ KN/m}^2
 \end{aligned}$$

c) Untuk haluan kapal

$$\begin{aligned}
 Ps_3 &= 10 \times (T - Z) + Po_1 \times C_{F3} \left(1 + \frac{Z}{T} \right) \\
 &= 10 (7,15 - 2,38) + 22,88 \times 2,556 \left[1 + \frac{2,38}{7,15} \right] \\
 &= 125,63 \text{ KN/m}^2
 \end{aligned}$$

2) Beban sisi kapal di bawah garis air muat untuk main frame.

a) Untuk buritan kapal

$$\begin{aligned}
 Ps_1 &= 10 \times (T - Z) + Po_2 \times C_{F1} \left(1 + \frac{Z}{T} \right) \\
 &= 10 (7,15 - 2,38) + 17,16 \times 1,735 \left[1 + \frac{2,38}{7,15} \right] \\
 &= 87,36 \text{ KN/m}^2
 \end{aligned}$$

b) Untuk midship kapal

$$\begin{aligned} P_{S_2} &= 10 \times (T - Z) + P_{O_2} \times C_{F_2} \left(1 + \frac{Z}{T}\right) \\ &= 10 (7,15 - 2,38) + 17,16 \times 1,0 \left[1 + \frac{2,38}{7,15}\right] \\ &= 70,54 \text{ KN/m}^2 \end{aligned}$$

c) Untuk haluan kapal

$$\begin{aligned} P_{S_3} &= 10 \times (T - Z) + P_{O_2} \times C_{F_3} \left(1 + \frac{Z}{T}\right) \\ &= 10 (7,15 - 2,38) + 17,16 \times 2,556 \left[1 + \frac{2,38}{7,15}\right] \\ &= 106,14 \text{ KN/m}^2 \end{aligned}$$

3) Beban sisi kapal di bawah garis air muat untuk web frame dan stringers.

a) Untuk buritan kapal

$$\begin{aligned} P_{S_1} &= 10 \times (T - Z) + P_{O_3} \times C_{F_1} \left(1 + \frac{Z}{T}\right) \\ &= 10 (7,15 - 2,38) + 13,73 \times 1,735 \left[1 + \frac{2,38}{7,15}\right] \\ &= 79,42 \text{ KN/m}^2 \end{aligned}$$

b) Untuk midship kapal

$$\begin{aligned} P_{S_2} &= 10 \times (T - Z) + P_{O_3} \times C_{F_2} \left(1 + \frac{Z}{T}\right) \\ &= 10 (7,15 - 2,38) + 13,73 \times 1,0 \left[1 + \frac{2,38}{7,15}\right] \\ &= 65,97 \text{ KN/m}^2 \end{aligned}$$

c) Untuk haluan kapal

$$\begin{aligned} P_{S_3} &= 10 \times (T - Z) + P_{O_3} \times C_{F_3} \left(1 + \frac{Z}{T}\right) \\ &= 10 (7,15 - 2,38) + 13,73 \times 2,556 \left[1 + \frac{2,38}{7,15}\right] \\ &= 94,44 \text{ KN/m}^2 \end{aligned}$$

- b. Beban sisi kapal di atas garis air muat tidak boleh kurang dari rumus sebagai berikut :

$$P_s = P_o \times CF \times \left(\frac{20}{10+Z-T} \right) \text{ KN/m}^2$$

(Ref : BKI Th.2006 Vol. II Sec. 4.B.2.1.2)

Dimana :

$$P_{o1} = 22,88 \text{ KN/m}^2 \quad \text{untuk plat kulit dan geladak cuaca}$$

$$T = 7,15 \text{ m}$$

$$Z = T + \frac{1}{2} (H - T)$$

$$Z = 7,15 + \frac{1}{2} (8,81 - 7,15)$$

$$= 7,98 \text{ m}$$

$$Cf_1 = 1,735 \quad \text{Untuk Buritan Kapal}$$

$$Cf_2 = 1,0 \quad \text{Untuk Midship}$$

$$Cf_3 = 2,556 \quad \text{Untuk Haluan Kapal}$$

- 1) Beban sisi kapal di atas garis air muat untuk menghitung ketebalan plat sisi :

- a) Untuk Buritan kapal

$$\begin{aligned} P_{s1} &= P_{o1} \times CF_1 \times \left(\frac{20}{10+Z_1-T} \right) \\ &= 22,88 \times 1,735 \left[\frac{20}{10+7,98-7,15} \right] \\ &= 73,29 \text{ KN/m}^2 \end{aligned}$$

- b) Untuk Midship kapal

$$\begin{aligned} P_{s2} &= P_{o1} \times CF_2 \times \left(\frac{20}{10+Z_1-T} \right) \\ &= 22,88 \times 1,0 \times \left[\frac{20}{10+7,98-7,15} \right] \\ &= 42,24 \text{ KN/m}^2 \end{aligned}$$

c) Untuk haluan kapal

$$\begin{aligned}
 P_{s3} &= P_{o1} \times CF_3 \left(\frac{20}{10 + Z_1 - T} \right) \\
 &= 22,88 \times 2,556 \times \left[\frac{20}{10 + 7,98 - 7,15} \right] \\
 &= 107,98 \text{ KN/m}^2
 \end{aligned}$$

c. Beban sisi kapal di atas Garis air muat pada bangunan atas (Superstructure Decks) dan rumah geladak (Deck Houses).

Beban geladak pada bangunan atas dan rumah geladak dihitung berdasarkan formula sbb :

$$P_s = P_o \times C_f \times \left[\frac{20}{10 + Z - T} \right] \quad [\text{KN/m}^2]$$

(Ref : BKI Th. 2006 Vol. II Sec. 2.1.2)

Dimana :

$P_{o1} = 22,88 \text{ KN/m}^2$ untuk plat kulit dan geladak cuaca

$P_{o2} = 17,16 \text{ KN/m}^2$ untuk untuk main frame dan deck beam

$P_{o3} = 13,73 \text{ KN/m}^2$ untuk web frame

$h_1, h_2, h_3 = 2,2 \text{ m}$

$H = 8,81 \text{ m}$

Nilai Z bangunan atas dan rumah geladak untuk beban geladak :

1. $Z_2 = H + (0,5 \times 2,2) = 9,91 \text{ m}$ (poop deck)
2. $Z_3 = Z_2 + (0,5 \times 2,2) = 11,01 \text{ m}$ (boat deck)
3. $Z_4 = Z_3 + (0,5 \times 2,2) = 12,11 \text{ m}$ (navigation deck)
4. $Z_5 = Z_4 + (0,5 \times 2,2) = 13,21 \text{ m}$ (compas deck)
5. $Z_6 = H + (0,5 \times 2,2) = 9,91 \text{ m}$ (forcastle deck)

1) Beban sisi di atas garis air muat pada Geladak Kimbul (Poop Deck) :

a) Untuk menghitung Plat kulit :

Dimana :

PROFILE CONSTRUCTION

TUGAS AKHIR KM "BAHARI JAYA" GC 3805 BRT

$$Z_2 = 9,91 \text{ m}$$

$$C_{F1} = 1,735$$

$$P_{O1} = 22,88 \text{ KN/m}^2$$

Sehingga :

$$\begin{aligned} P_{S1} &= P_{O1} \times C_{F1} \times \left(\frac{20}{10 + Z_2 - T} \right) \\ &= 22,88 \times 1,735 \times \left[\frac{20}{10 + 9,91 - 7,15} \right] \\ &= 62,208 \text{ KN/m}^2 \end{aligned}$$

b) Untuk menghitung Main Frame :

Dimana :

$$Z_2 = 9,91 \text{ m}$$

$$C_{F1} = 1,735$$

$$P_{O2} = 17,16 \text{ KN/m}^2$$

Sehingga :

$$\begin{aligned} P_{S1} &= P_{O2} \times C_{F1} \times \left(\frac{20}{10 + Z_2 - T} \right) \\ &= 17,16 \times 1,735 \times \left[\frac{20}{10 + 9,91 - 7,15} \right] \\ &= 46,656 \text{ KN/m}^2 \end{aligned}$$

c) Untuk menghitung web frame :

Dimana :

$$Z_2 = 9,91 \text{ m}$$

$$C_{F1} = 1,735$$

$$P_{O3} = 13,73 \text{ KN/m}^2$$

Sehingga :

$$\begin{aligned} P_{S1} &= P_{O3} \times C_{F1} \times \left(\frac{20}{10 + Z_2 - T} \right) \\ &= 13,73 \times 1,735 \times \left[\frac{20}{10 + 9,91 - 7,15} \right] \\ &= 37,325 \text{ KN/m}^2 \end{aligned}$$

2) **Beban sisi di atas garis air muat pada Geladak Sekoci (Boat Deck)**

a) Untuk menghitung Plat sisi :

Dimana :

$$Z_3 = 11,01 \text{ m}$$

$$C_{F1} = 1,735$$

$$P_{O1} = 22,88 \text{ KN/m}^2$$

Sehingga :

$$\begin{aligned} P_{S1} &= P_{O1} \times C_{F1} \times \left(\frac{20}{10 + Z_3 - T} \right) \\ &= 11,01 \times 1,735 \times \left[\frac{20}{10 + 11,01 - 7,15} \right] \\ &= 57,271 \text{ KN/m}^2 \end{aligned}$$

b) Untuk menghitung Main Frame :

Dimana :

$$Z_3 = 11,01 \text{ m}$$

$$C_{F1} = 1,735$$

$$P_{O2} = 17,16 \text{ KN/m}^2$$

Sehingga :

$$\begin{aligned} P_{S1} &= P_{O2} \times C_{F1} \times \left(\frac{20}{10 + Z_3 - T} \right) \\ &= 17,16 \times 1,735 \times \left[\frac{20}{10 + 11,01 - 7,15} \right] \\ &= 42,953 \text{ KN/m}^2 \end{aligned}$$

c) Untuk menghitung web frame :

Dimana :

$$Z_3 = 11,01 \text{ m}$$

$$C_{F1} = 1,735$$

$$P_{O3} = 13,73 \text{ KN/m}^2$$

Sehingga :

$$\begin{aligned} P_{S1} &= P_{O3} \times C_{F1} \times \left(\frac{20}{10 + Z_3 - T} \right) \\ &= 13,73 \times 1,735 \times \left[\frac{20}{10 + 11,01 - 7,15} \right] \\ &= 34,363 \text{ KN/m}^2 \end{aligned}$$

3) Beban sisi di atas garis air muat pada Deck Kemudi (navigasi deck)

a) Untuk menghitung Plat sisi :

Dimana :

$$Z_4 = 12,11 \text{ m}$$

$$C_{F1} = 1,735$$

$$P_{O1} = 22,88 \text{ KN/m}^2$$

Sehingga :

$$\begin{aligned} P_{S1} &= P_{O1} \times C_{F1} \times \left(\frac{20}{10 + Z_4 - T} \right) \\ &= 22,88 \times 1,735 \times \left[\frac{20}{10 + 12,11 - 7,15} \right] \\ &= 53,06 \text{ KN/m}^2 \end{aligned}$$

b) Untuk menghitung Main Frame :

Dimana :

$$Z_4 = 12,11 \text{ m}$$

$$C_{F1} = 1,735$$

$$P_{O2} = 17,16 \text{ KN/m}^2$$

Sehingga :

$$\begin{aligned} P_{S1} &= P_{O2} \times C_{F1} \times \left(\frac{20}{10 + Z_4 - T} \right) \\ &= 17,16 \times 1,735 \times \left[\frac{20}{10 + 12,11 - 7,15} \right] \\ &= 39,795 \text{ KN/m}^2 \end{aligned}$$

c) Untuk menghitung web frame :

Dimana :

$$Z_4 = 12,11 \text{ m}$$

$$C_{F1} = 1,735$$

$$P_{O3} = 13,73 \text{ KN/m}^2$$

Sehingga :

$$\begin{aligned} P_{S1} &= P_{O3} \times C_{F1} \times \left(\frac{20}{10 + Z_4 - T} \right) \\ &= 13,73 \times 1,735 \times \left[\frac{20}{10 + 12,11 - 7,15} \right] \\ &= 31,836 \text{ KN/m}^2 \end{aligned}$$

4) Beban sisi di atas garis air muat pada Deck Kompas (compass deck)

a) Untuk menghitung Plat sisi :

Dimana :

$$Z_5 = 13,21 \text{ m}$$

$$C_{F1} = 1,735$$

$$P_{O1} = 22,88 \text{ KN/m}^2$$

Sehingga :

$$\begin{aligned} P_{S1} &= P_{O1} \times C_{F1} \times \left(\frac{20}{10 + Z_5 - T} \right) \\ &= 22,88 \times 1,735 \times \left[\frac{20}{10 + 13,21 - 7,15} \right] \\ &= 49,426 \text{ KN/m}^2 \end{aligned}$$

b) Untuk menghitung Main Frame :

Dimana :

$$Z_5 = 13,21 \text{ m}$$

$$C_{F1} = 1,735$$

$$P_{O2} = 17,16 \text{ KN/m}^2$$

Sehingga :

$$\begin{aligned} P_{S1} &= P_{O2} \times C_{F1} \times \left(\frac{20}{10 + Z_5 - T} \right) \\ &= 17,16 \times 1,735 \times \left[\frac{20}{10 + 13,21 - 7,15} \right] \\ &= 37,069 \text{ KN/m}^2 \end{aligned}$$

c) Untuk menghitung web frame :

Dimana :

$$Z_5 = 13,21 \text{ m}$$

$$C_{F1} = 1,735$$

$$P_{O3} = 13,73 \text{ KN/m}^2$$

Sehingga :

$$\begin{aligned} P_{S1} &= P_{O3} \times C_{F1} \times \left(\frac{20}{10 + Z_5 - T} \right) \\ &= 13,73 \times 1,735 \times \left[\frac{20}{10 + 13,21 - 7,15} \right] \\ &= 29,655 \text{ KN/m}^2 \end{aligned}$$

5) Beban sisi di atas garis air muat untuk menghitung Geladak Akil (Fore Castle deck)

a) Untuk menghitung Plat kulit :

Dimana :

$$Z_6 = Z_1 = 9,91 \text{ m}$$

$$C_{F3} = 2,556$$

$$P_{O1} = 22,88 \text{ KN/m}^2$$

Sehingga :

$$\begin{aligned} P_{S1} &= P_{O1} \times C_{F3} \times \left(\frac{20}{10 + Z_6 - T} \right) \\ &= 22,88 \times 2,556 \times \left[\frac{20}{10 + 9,91 - 7,15} \right] \\ &= 91,645 \text{ KN/m}^2 \end{aligned}$$

b) Untuk menghitung Main Frame:

Dimana :

$$Z_6 = Z_1 = 9,91 \text{ m}$$

$$C_{F3} = 2,556$$

$$P_{O2} = 17,16 \text{ KN/m}^2$$

Sehingga :

$$\begin{aligned} P_{S1} &= P_{O2} \times C_{F3} \times \left(\frac{20}{10 + Z_6 - T} \right) \\ &= 17,16 \times 2,556 \times \left[\frac{20}{10 + 9,91 - 7,15} \right] \\ &= 68,734 \text{ KN/m}^2 \end{aligned}$$

c) Untuk menghitung web frame :

Dimana :

$$Z_6 = Z_1 = 9,91 \text{ m}$$

$$C_{F3} = 2,556$$

$$P_{O3} = 13,73 \text{ KN/m}^2$$

Sehingga :

$$\begin{aligned} P_{S1} &= P_{O3} \times C_{F3} \times \left(\frac{20}{10 + Z_6 - T} \right) \\ &= 13,73 \times 2,556 \times \left[\frac{20}{10 + 9,91 - 7,15} \right] \\ &= 54,987 \text{ KN/m}^2 \end{aligned}$$

6) Beban sisi di atas garis air muat untuk menghitung Winch Deck

a) Untuk menghitung Plat sisi :

Dimana :

$$Z_7 = Z_1 = 9,91 \text{ m}$$

$$C_{F2} = 1,0$$

$$P_{O1} = 22,88 \text{ KN/m}^2$$

Sehingga :

$$\begin{aligned} P_{S1} &= P_{O1} \times C_{F3} \times \left(\frac{20}{10 + Z_7 - T} \right) \\ &= 22,88 \times 1,0 \times \left[\frac{20}{10 + 9,91 - 7,15} \right] \\ &= 22,979 \text{ KN/m}^2 \end{aligned}$$

b) Untuk menghitung Main Frame :

Dimana :

$$Z_7 = Z_1 = 9,91 \text{ m}$$

$$C_{F2} = 2,556$$

$$P_{O2} = 17,16 \text{ KN/m}^2$$

Sehingga :

$$\begin{aligned} P_{S1} &= P_{O2} \times C_{F3} \times \left(\frac{20}{10 + Z_7 - T} \right) \\ &= 17,16 \times 1,0 \times \left[\frac{20}{10 + 9,91 - 7,15} \right] \\ &= 17,234 \text{ KN/m}^2 \end{aligned}$$

c) Untuk menghitung web frame :

Dimana :

$$Z_7 = Z_1 = 9,91 \text{ m}$$

$$C_{F2} = 2,556$$

$$P_{O3} = 13,73 \text{ KN/m}^2$$

Sehingga :

$$\begin{aligned} P_{S1} &= P_{O3} \times C_{F3} \times \left(\frac{20}{10 + Z_7 - T} \right) \\ &= 13,73 \times 1,0 \times \left[\frac{20}{10 + 9,91 - 7,15} \right] \\ &= 13,787 \text{ KN/m}^2 \end{aligned}$$

A.4 Beban Alas Kapal

Beban luar pada alas / dasar kapal adalah dihitung menurut formula sebagai berikut :

$$P_B = 10 \times T + P_o \times C_f \quad \text{KN/m}^2$$

(Ref : BKI Th. 2006 Vol. II Sec.4. B.3)

Dimana :

$$T = 7,15 \text{ m}$$

$$P_{O1} = 22,88 \text{ KN/m}^2 \quad \text{untuk plat kulit dan geladag cuaca}$$

$$P_{O2} = 17,16 \text{ KN/m}^2 \quad \text{untuk untuk frame, deck beam dan bottom}$$

$$C_{f1} = 1,735 \quad \text{untuk buritan kapal}$$

$$C_{f2} = 1,0 \quad \text{untuk Midship kapal}$$

$$C_{f3} = 2,556 \quad \text{untuk Haluan kapal}$$

a. Beban alas kapal untuk menghitung plat Alas

1). Untuk Buritan kapal

$$\begin{aligned} P_{B1} &= 10 \times T + P_{O1} \times C_{f1} \\ &= 10 \times 7,15 + 22,88 \times 1,735 \\ &= 111,189 \text{ KN/m}^2 \end{aligned}$$

2). Untuk Midship kapal

$$\begin{aligned} P_{B2} &= 10 \times T + P_{O1} \times C_{f2} \\ &= 10 \times 7,15 + 22,88 \times 1,0 \\ &= 94,375 \text{ KN/m}^2 \end{aligned}$$

3). Untuk haluan kapal

$$\begin{aligned} P_{B3} &= 10 \times T + P_{O1} \times C_{f3} \\ &= 10 \times 7,15 + 22,88 \times 2,556 \\ &= 129,970 \text{ KN/m}^2 \end{aligned}$$

b. Beban alas untuk menghitung bottom frame

1). Untuk Midship kapal

$$\begin{aligned} P_{B2} &= 10 \times T + P_{O2} \times C_{f2} \\ &= 10 \times 7,15 + 17,16 \times 1,0 \\ &= 88,657 \text{ KN/m}^2 \end{aligned}$$

A.5. Beban Alas Dalam (Load on inner bottom)

Beban alas dalam dihitung dengan formula sebagai berikut :

$$P_B = 9,81 \times \frac{G}{V} \times h (1 + av) \quad \text{KN/m}^2$$

(Ref : BKI Th. 2006 Vol. II Sec. 4.C.2.1)

Dimana :

$$G = \text{Berat muatan bersih} = 4618,044 \text{ Ton}$$

$$V = \text{Volume muatan kapal} = 6696,164 \text{ m}^3$$

$$H = H - h_{DB \text{ KM}} \quad \text{untuk buritan, kamar mesin}$$

$$= 8,81 - 1,44$$

$$= 7,37 \text{ m}$$

$$H = H - h_{db} \quad \text{untuk midship dan haluan}$$

$$= 8,81 - 1,2$$

$$= 7,61 \text{ m}$$

$$av = F \times m$$

$$F = 0,11 \times \frac{V_o}{\sqrt{L}} \quad \text{dimana } V_o = 12,50 \text{ Knots}$$

Sehingga :

$$F = 0,11 \times \frac{13,75}{\sqrt{98,68}}$$

$$= 0,138$$

$$m_o = 1,5 + F$$

$$= 1,5 + 0,138$$

$$= 1,638$$

$$m_1 = m_o - 5 [m_o - 1] \times L \quad \text{untuk Buritan kapal}$$

$$= 1,638 - 5 [1,638 - 1] \times 0,1$$

PROFILE CONSTRUCTION

TUGAS AKHIR KM "BAHARI JAYA" GC 3805 BRT

$$= 1,319$$

$$m_2 = 1,0 \quad \text{untuk Midship}$$

$$m_3 = 1 + \frac{mo + 1}{0,3} (X/L - 0,7) \quad \text{untuk Haluan kapal}$$

$$= 1 + \frac{1,638 + 1}{0,3} \times (0,8 - 0,7)$$

$$= 1,879$$

sehingga ;

$$av_1 = F \times m_1 \quad \text{untuk buritan kapal}$$

$$= 0,138 \times 1,319$$

$$= 0,182$$

$$av_2 = F \times m_2 \quad \text{untuk Midship}$$

$$= 0,138 \times 1,0$$

$$= 0,138$$

$$av_3 = F \times m_3 \quad \text{untuk Haluan kapal}$$

$$= 0,138 \times 1,879$$

$$= 0,260$$

Jadi beban alas dalam (P_B) :

a). Untuk Buritan kapal

$$\begin{aligned} P_B &= 9,81 \times \frac{G}{V} \times h (1 + av_1) \\ &= 9,81 \times \frac{4618,044}{6696,164} \times 8,81 (1 + 0,182) \\ &= 70,488 \quad \text{KN/m}^2 \end{aligned}$$

b). Untuk Midship kapal

$$\begin{aligned} P_B &= 9,81 \times \frac{G}{V} \times h (1 + av_2) \\ &= 9,81 \times \frac{4618,044}{6696,164} \times 8,81 (1 + 0,138) \\ &= 67,854 \quad \text{KN/m}^2 \end{aligned}$$

c). Untuk haluan kapal

$$\begin{aligned}
 P_B &= 9,81 \times \frac{G}{V} \times h (1 + av_3) \\
 &= 9,81 \times \frac{4618,044}{6696,164} \times 8,81 (1+0,260) \\
 &= 75,110 \quad \text{KN/m}^2
 \end{aligned}$$

B. PERHITUNGAN PLAT KULIT DAN PLAT GELADAK KEKUATAN

B.1. Menentukan Tebal Plat Geladak

a. Menentukan Tebal plat geladak Cuaca

Tebal plat geladak cuaca pada kapal tidak boleh kurang dari :

$$t_{G_1} = 1,21 \times a \sqrt{P_D \times k} + t_k \quad (\text{mm})$$

(Ref : BKI Th. 2006 Vol. II Sec. 7.C.7.1)

Dimana :

P_{D1}	= 35,03 KN/m ²	untuk buritan kapal
P_{D2}	= 31,84 KN/m ²	untuk midship kapal
P_{D3}	= 44,05 KN/m ²	untuk haluan kapal
a	= jarak antar gading	
	= 0,6 m (pada AP – fr 10)	
	= 0,62 m (pada fr. 10 – fr. 144)	
	= 0,6 m (pada fr. 144 – fr. 160)	
k	= 1,0 faktor bahan	
t _k	= 1,5 untuk t _B ≤ 10 mm	
t _k	= 0,5 untuk t _B ≥ 10 mm	

1) Tebal plat geladak pada 0,1 L pada buritan kapal tidak boleh kurang dari :

$$\begin{aligned}
 t_{G_1} &= 1,21 \times 0,62 \times \sqrt{35,03 \times 1} + 1,5 \\
 &= \mathbf{5,94 \text{ mm}}
 \end{aligned}$$

2) Tebal plat geladak pada daerah midship

PROFILE CONSTRUCTION

TUGAS AKHIR KM "BAHARI JAYA" GC 3805 BRT

$$\begin{aligned}tG_2 &= 1,21 \times 0,62 \times \sqrt{31,84 \times 1} + 1,5 \\ &= \mathbf{5,73 \text{ mm}}\end{aligned}$$

3) Tebal plat geladak pada daerah haluan kapal

$$\begin{aligned}tG_3 &= 1,21 \times 0,6 \times \sqrt{44,05 \times 1} + 1,5 \\ &= \mathbf{6,47 \text{ mm}}\end{aligned}$$

$$\begin{aligned}tG_{\min} &= (4,5 + 0,05L) \sqrt{k} && \text{(Haluan \& buritan)} \\ &= (4,5 + 0,05 \times 98,68) \sqrt{1} \\ &= \mathbf{9,434 \text{ mm}}\end{aligned}$$

$$\begin{aligned}tG_{\min} &= (5,5 + 0,02L) \sqrt{k} && \text{(Midship)} \\ &= (5,5 + 0,02 \times 98,68) \sqrt{1} \\ &= \mathbf{7,473 \text{ mm}}\end{aligned}$$

❖ Karena tebal plat yang direncanakan lebih kecil dari tebal plat minimum, maka diambil tebal plat minimum :

1) Tebal plat geladak buritan

$$tG = t_{\min} + 1 = 9,434 + 1 = 10,434 \approx 11 \text{ mm}$$

2) Tebal plat geladak midship

$$tG = t_{\min} + 1 = 7,473 + 1 = 8,473 \approx 9 \text{ mm}$$

3) Tebal plat geladak buritan

$$tG = t_{\min} + 1 = 9,434 + 1 = 10,434 \approx 11 \text{ mm}$$

b. Tebal plat geladak bangunan atas

$$tG = 1,21 \times a \sqrt{P_D \times k} + tk \quad (\text{mm})$$

(Ref : BKI Th. 2006 Vol. II Sec. 7.C.7.1)

1) Tebal plat geladak kimbul (poop deck)

$$\begin{aligned}tG_1 &= 1,21 \times 0,62 \times \sqrt{27,322 \times 1} + 1,5 \\ &= \mathbf{5,42 \text{ mm} \approx 9 \text{ mm}}\end{aligned}$$

2) Tebal plat geladak sekoci (Boat Deck)

$$tG_2 = 1,21 \times 0,62 \times \sqrt{19,616 \times 1} + 1,5$$

PROFILE CONSTRUCTION

TUGAS AKHIR KM “BAHARI JAYA” GC 3805 BRT

$$= 4,82 \text{ mm} \approx 8 \text{ mm}$$

3) Tebal plat geladak navigasi

$$t_{G_3} = 1,21 \times 0,62 \times \sqrt{17,514 \times 1} + 1,5$$

$$= 4,63 \text{ mm} \approx 7 \text{ mm}$$

4) Tebal plat geladak kompas (compass deck)

$$t_{G_4} = 1,21 \times 0,62 \times \sqrt{17,514 \times 1} + 1,5$$

$$= 4,63 \text{ mm} \approx 7 \text{ mm}$$

5) Tebal plat geladak akil (fore castle deck)

$$t_{G_5} = 1,21 \times 0,62 \times \sqrt{44,051 \times 1} + 1,5$$

$$= 6,47 \text{ mm} \approx 9 \text{ mm}$$

6) Tebal plat geladak Derek (winch deck)

$$t_{G_6} = 1,21 \times 0,62 \times \sqrt{24,839 \times 1} + 1,5$$

$$= 5,23 \text{ mm} \approx 8 \text{ mm}$$

B.2. Menentukan Tebal Plat sisi Kapal

a. Tebal plat sisi kapal di bawah garis air muat adalah sbb :

$$t_s = 1,21 \times a \times \sqrt{P_s \times k} + t_k \quad (\text{mm}), \text{ Untuk } L \geq 90 \text{ m}$$

(Ref : BKI Th. 2006 Vol. II Sec. 6.C.1.2)

Dimana :

$$P_{S1} = 100,59 \quad \text{KN/m}^2 \quad \text{untuk buritan kapal}$$

$$P_{S2} = 78,17 \quad \text{KN/m}^2 \quad \text{untuk midship kapal}$$

$$P_{S3} = 125,63 \quad \text{KN/m}^2 \quad \text{untuk haluan kapal}$$

a = jarak antar gading

$$= 0,6 \text{ m (pada AP – fr 10)}$$

$$= 0,62 \text{ m (pada fr. 10 – fr. 144)}$$

$$= 0,6 \text{ m (pada fr. 144 – fr. 160)}$$

k = 1,0 faktor bahan

t_k = 1,5 untuk t_B ≤ 10 mm

1) Tebal plat sisi kapal pada 0,05 L pada buritan kapal tidak boleh kurang dari :

PROFILE CONSTRUCTION

TUGAS AKHIR KM "BAHARI JAYA" GC 3805 BRT

$$\begin{aligned}ts_1 &= 1,21 \times 0,62 \times \sqrt{100,59x1} + 1,5 \\ &= \mathbf{9,02 \text{ mm}}\end{aligned}$$

2) Tebal plat sisi pada daerah midship

$$\begin{aligned}ts_2 &= 1,21 \times 0,62 \times \sqrt{78,17x1} + 1,5 \\ &= \mathbf{8,13 \text{ mm}}\end{aligned}$$

3) Tebal plat sisi pada daerah haluan kapal

$$\begin{aligned}ts_3 &= 1,21 \times 0,6 \times \sqrt{125,63x1} + 1,5 \\ &= \mathbf{9,90 \text{ mm}}\end{aligned}$$

❖ Karena tebal plat yang direncanakan lebih kecil dari tebal plat minimum, maka diambil tebal plat minimum :

1) Tebal plat sisi buritan

$$tS = t_{\min} + 2 = 9,434 + 2 = 11,434 \approx 12 \text{ mm}$$

2) Tebal plat sisi midship

$$tS = t_{\min} + 2 = 7,473 + 2 = 8,473 \approx 9 \text{ mm}$$

3) Tebal plat sisi buritan

$$tS = t_{\min} + 2 = 9,434 + 2 = 11,434 \approx 12 \text{ mm}$$

b. Ketebalan plat sisi kapal di atas garis air muat adalah sbb :

$$ts = 1,21 \times a \times \sqrt{P_s \times k} + tk \quad \text{Untuk } L \geq 90 \text{ m}$$

(Ref : BKI Th. 2006 Vol. II Sec. 6.C.1.2)

Dimana :

$$P_{S1} = 73,29 \text{ KN/m}^2 \quad \text{untuk buritan kapal}$$

$$P_{S2} = 42,24 \text{ KN/m}^2 \quad \text{untuk midship kapal}$$

$$P_{S3} = 107,98 \text{ KN/m}^2 \quad \text{untuk haluan kapal}$$

a = jarak antar gading

$$= 0,6 \text{ m (pada AP – fr 10)}$$

$$= 0,62 \text{ m (pada fr. 10 – fr. 144)}$$

$$= 0,6 \text{ m (pada fr. 144 – fr. 160)}$$

$$k = 1,0 \quad \text{faktor bahan}$$

$$tk = 1,5 \quad \text{untuk } t_B \leq 10 \text{ mm}$$

jadi :

- 1) Tebal plat sisi pada 0,1 L pada buritan kapal tidak boleh kurang dari :

$$\begin{aligned} ts_1 &= 1,21 \times 0,62 \times \sqrt{73,29x1} + 1,5 \\ &= \mathbf{7,92 \text{ mm} \approx 9 \text{ mm}} \end{aligned}$$

- 2) Tebal plat sisi pada daerah midship

$$\begin{aligned} ts_2 &= 1,21 \times 0,62 \times \sqrt{42,24x1} + 1,5 \\ &= \mathbf{6,37 \text{ mm} \approx 7 \text{ mm}} \end{aligned}$$

- 3) Tebal plat sisi pada daerah haluan kapal

$$\begin{aligned} ts_3 &= 1,21 \times 0,62 \times \sqrt{107,98x1} + 1,5 \\ &= \mathbf{9,29 \text{ mm} \approx 9,5 \text{ mm}} \end{aligned}$$

c. Tebal Plat Sisi Geladak Bangunan Atas

$$T_s = 1,21 \times a \times \sqrt{P_s \times k} + tk \quad (\text{mm})$$

(Ref : BKI Th. 2006 Vol. II Sec. 6.C.1.2)

- 1) Tebal plat sisi geladak kembang (poop deck)

$$\begin{aligned} t_{S_1} &= 1,21 \times 0,62 \times \sqrt{62,208x1} + 1,5 \\ &= \mathbf{7,41 \text{ mm} \approx 7,5 \text{ mm}} \end{aligned}$$

- 2) Tebal plat sisi geladak sekoci (Boat Deck)

$$\begin{aligned} t_{S_2} &= 1,21 \times 0,62 \times \sqrt{57,27x1} + 1,5 \\ &= \mathbf{7,17 \text{ mm} \approx 7,5 \text{ mm}} \end{aligned}$$

- 3) Tebal plat sisi geladak navigasi

$$\begin{aligned} t_{S_3} &= 1,21 \times 0,62 \times \sqrt{53,060x1} + 1,5 \\ &= \mathbf{6,96 \text{ mm} \approx 7 \text{ mm}} \end{aligned}$$

- 4) Tebal plat sisi geladak kompas (compass deck)

$$\begin{aligned} t_{S_4} &= 1,21 \times 0,62 \times \sqrt{49,426x1} + 1,5 \\ &= \mathbf{6,77 \text{ mm} \approx 7 \text{ mm}} \end{aligned}$$

- 5) Tebal plat sisi geladak akil (fore castle deck)

$$t S_5 = 1,21 \times 0,62 \times \sqrt{91,645 \times 1} + 1,5$$

$$= \mathbf{8,68 \text{ mm} \approx 9 \text{ mm}}$$

6) Tebal plat sisi winch deck

$$t S_6 = 1,21 \times 0,62 \times \sqrt{22,979 \times 1} + 1,5$$

$$= \mathbf{5,09 \text{ mm} \approx 7 \text{ mm}}$$

B.3. Menentukan Tebal Plat Alas Kapal (Bottom Plate)

$$T_B = 1,21 \times n_f \times a \times \sqrt{P_B \times k} + t_k \text{ (mm) , Untuk } L \geq 90 \text{ m}$$

(Ref : BKI Th. 2006 Vol. II Sec. 6.B.1.1)

Dimana :

$P_{B1} = 111,186$	KN/m^2	untuk buritan kapal
$P_{B2} = 94,375$	KN/m^2	untuk midship kapal
$P_{B3} = 129,970$	KN/m^2	untuk haluan kapal
$n_f = 1,0$		
$a =$	jarak antar gading	
	$= 0,6 \text{ m}$ (pada AP – fr 10)	
	$= 0,62 \text{ m}$ (pada fr. 10 – fr. 144)	
	$= 0,6 \text{ m}$ (pada fr. 144 – fr. 160)	
$k = 1$		
$t_k = 1,5$		

1) Tebal plat alas pada daerah buritan kapal

$$t B_1 = 1,21 \times 1,0 \times 0,62 \times \sqrt{111,189 \times 1} + 1,5$$

$$= \mathbf{9,41 \text{ mm}}$$

2) Tebal plat alas pada daerah midship

$$t B_1 = 1,21 \times 1,0 \times 0,62 \times \sqrt{94,375 \times 1} + 1,5$$

$$= \mathbf{8,78 \text{ mm}}$$

3) Tebal plat alas pada daerah haluan kapal

$$t B_1 = 1,21 \times 1,0 \times 0,62 \times \sqrt{129,970 \times 1} + 1,5$$

$$= \mathbf{10,05 \text{ mm}}$$

$$\begin{aligned}
 t_{\min} &= \sqrt{Lxk} && \text{Untuk } L \geq 50 \text{ m} \\
 &= \sqrt{98,68 \times 1,0} \\
 &= \mathbf{9,933 \text{ mm}}
 \end{aligned}$$

❖ Karena tebal plat yang direncanakan lebih kecil dari tebal plat minimum, maka diambil tebal plat minimum :

1) Tebal plat alas buritan

$$tB = t_{\min} + 2 = 9,933 + 2 = 11,933 \approx 12 \text{ mm}$$

2) Tebal plat alas midship

$$tB = t_{\min} + 2 = 9,933 + 2 = 11,933 \approx 12 \text{ mm}$$

3) Tebal plat alas buritan

$$tB = t_{\min} + 2 = 9,933 + 2 = 11,933 \approx 12 \text{ mm}$$

B.4. Menentukan Tebal Plat Lajur Bilga

a. Tebal plat lajur bilga diambil harga terbesar dari harga tebal plat alas atau plat sisi (*BKI Th. 2006 Vol. II Sec 6.B.4.2*).

1) Tebal plat-plat lajur bilga pada daerah 0,05 L dari AP = 12 mm

2) Tebal plat-plat lajur bilga pada daerah 0,4 L midship = 12 mm

3) Tebal plat-plat lajur bilga pada daerah 0,1 L dari FP = 12 mm

b. Lebar lajur bilga tidak boleh kurang dari :

$$\begin{aligned}
 b &= 800 + 5 L \\
 &= 800 + 5 (98,68) \\
 &= 1293,4 \text{ mm} \approx 1300 \text{ mm}
 \end{aligned}$$

(*Ref : BKI Th. 2006 Vol. II Sec. 6.B.4.2*)

B.5 Menentukan Plat Lajur Atas (Sheer Strake)

a. Lebar plat sisi lajur atas tidak boleh kurang dari :

$$\begin{aligned}
 b &= 800 + 5 L \\
 &= 800 + 5 (98,68) \\
 &= 1293,4 \text{ mm} \approx 1300 \text{ mm}
 \end{aligned}$$

(*Ref : BKI Th. 2006 Vol. II Sec. 6.C.3.1*)

Tebal plat lajur atas di luar midship umumnya tebalnya sama dengan

$$t = 0,5 (t_D + t_S)$$

(Ref : BKI Th. 2006 Vol. II Sec. 6.C.3.2)

Dimana :

t_D : Tebal plat geladak

t_S : Tebal plat sisi

1) Pada 0,5L dari AP $t = 0,5 (11 + 9)$
 $= 10 \text{ mm}$

2) Pada 0,4L Midship $t = 0,5 (9 + 7)$
 $= 8 \text{ mm}$

3) Pada 0,5L dari FP $t = 0,5 (11 + 9,5)$
 $= 10,25 \text{ mm} \approx 10,5 \text{ mm}$

B.6. Plat penguat pada linggi buritan dan lunas, baling-baling dan lebar bilga

(Ref : BKI Th. 2006 Vol. II Sec. 6.F.1.1)

- Tebal plat kulit linggi buritan sekurang-kurangnya sama dengan plat sisi tengah kapal = 9 mm
- Tebal penyangga baling-baling harus dipertebal menjadi :

$$t = 1,5 + t_1$$

Dimana :

t_1 = tebal plat sisi pada 0,4 L tengah kapal
 $= 8,5 \text{ mm}$

Maka :

$$t = 1,5 + 8,5$$
$$= 10 \text{ mm}$$

- Tebal Plat lunas, $t_k = t_a + 2 = 12 + 2 = 14 \text{ mm}$

Lebar plat lunas tidak boleh kurang dari) :

(Ref : BKI Th. 2006 Vol. II Sec. 6.B.5.1)

$$b = 800 + 5 L$$
$$= 800 + 5 (98,68)$$
$$= 1293,4 \text{ mm} \approx 1300 \text{ mm}$$

PROFILE CONSTRUCTION

TUGAS AKHIR KM "BAHARI JAYA" GC 3805 BRT

d. Lunas bilga dipasang pada plat kulit bagian bawah yang sekelilingnya dilas kedap air. Sehingga jika ada sentuhan dengan dasar laut plat kulit tidak akan rusak.

e. Tebal pelat linggi haluan

Tebal plat linggi haluan tidak boleh kurang dari :

$$t = (0,6 + 0,4 aB) \times (0,08 L + 6) \sqrt{k} \quad (\text{mm})$$

(BKI Th. 2006 Vol II Sec 13.B.2.1)

Dimana :

aB = spacing of fore hooks
= 0,9 m

$$t = (0,6 + 0,4 \cdot 0,9) \times (0,08 \cdot 98,68 + 6) \sqrt{1} \\ = 13,338 \text{ mm} \approx 16 \text{ mm}$$

$$t_{\text{max}} = 25 \sqrt{1} \text{ mm} \\ = 25 \text{ mm}$$

B.7. Bukaan pada plat kulit

- Bukaan untuk jendela, lubang udara dan lubang pembuangan katub laut sudut-sudutnya harus dibulatkan dengan konstruksi kedap air.
- Pada lubang jangkar di haluan plat kulit harus dipertebal dengan doubling.
- Dibawah konstruksi pipa duga, pipa limbah, pipa udara dan alas diberi plat doubling.

B.8. Kotak laut (Sea Chest)

Tebal plat sea chest tidak boleh kurang dari :

$$T = 12 \times a \sqrt{P \times k} + tk \quad (\text{mm})$$

(Ref : BKI Th. 2006 Vol. II Sec. 8.B.5.4.1)

Dimana :

P = 2 Mws
a = 0,62 m

PROFILE CONSTRUCTION

TUGAS AKHIR KM "BAHARI JAYA" GC 3805 BRT

$$\begin{aligned}t &= 12 \times 0,62 \times \sqrt{2 \times 1} + 1,5 \\ &= 11,682 \text{ mm} \approx \text{diambil 12 mm}\end{aligned}$$

B.9. Kubu-kubu (Bulwark)

- a. Tebal kubu-kubu untuk kapal > 100 m tidak boleh kurang dari :

(Ref: BKI Th. 2006 Vol. II Sec. 6.K.1)

$$\begin{aligned}t &= 0,65\sqrt{L} \\ &= 0,65\sqrt{98,68}\end{aligned}$$

$$t = 6,457 \text{ mm} \approx 7 \text{ mm}$$

- b. Tinggi kubu-kubu minimal = 1000 mm
c. Stay Bulwark

$$W = 4 \times P_s \times e \times (l^2) \quad \text{cm}^3$$

(BKl Th 2006 Vol II Sec 6.K.4)

Dimana :

$$P_s = 43,98 \text{ KN/m}^2$$

e = jarak antar stay (m)

$$= 2 \times 0,62 = 1,24 \text{ m}$$

l = panjang stay (m)

$$= 1 \text{ m}$$

Sehingga :

$$\begin{aligned}W &= 4 \times 43,98 \times 1,24 \times (1^2) \\ &= 218,140 \text{ cm}^3\end{aligned}$$

Profil T = 190×9 FP 80 ×9

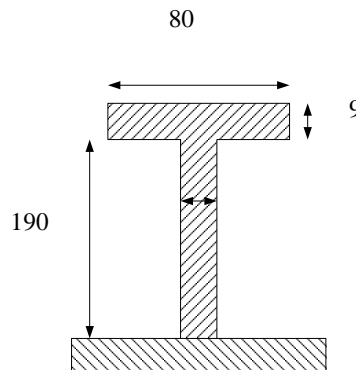

Koreksi modulus :

PROFILE CONSTRUCTION

TUGAS AKHIR KM "BAHARI JAYA" GC 3805 BRT

$$\text{Lebar berguna } (40 - 50) = 50$$

$$f = 8 \times 0,9 = 7,2 \text{ cm}^2$$

$$f_s = 19 \times 0,9 = 17,1 \text{ cm}^2$$

$$F = 50 \times 0,75 = 35,7 \text{ cm}^2$$

$$f/F = 0,19$$

$$f_s/F = 0,46$$

$$w = 0,31$$

$$\begin{aligned} W &= w \times F \times h \\ &= 0,31 \times 37,5 \times 19 \\ &= 220,88 \text{ cm}^3 \end{aligned}$$

W rencana > W perhitungan

$$\mathbf{220,88} > \mathbf{218,140} \quad (\text{memenuhi})$$

d. Freeing Ports

$$A = 0,07 L \text{ Untuk } L > 20 \text{ m}$$

(BKI Th 2006 Vol II Sec 21.D.2.2)

Dimana :

A = panjang freeing ports (m)

L = panjang bulwark (m)

$$= 61,8 \text{ m}$$

Sehingga :

$$A = 0,07 \times 61,8$$

$$= 4,326 \text{ m}$$

B.10. Tebal Plat Antara Lubang Palka

Tebal plat geladak pada 0,1 L dari ujung dan antara lubang palka tidak boleh kurang dari :

(Ref : BKI Th. 2006 Vol. II Sec. 7.A.7.1)

$$T_{t1} = 1,21 \times a \sqrt{P_D \times K} + tk \quad (\text{mm})$$

P_D = Beban geladak cuaca

$$= \mathbf{31,84} \text{ KN/m}^2$$

$$T_{t1} = 1,21 \times 0,62 \sqrt{31,84 \times 1} + 1,5 \text{ (mm)}$$

PROFILE CONSTRUCTION

TUGAS AKHIR KM "BAHARI JAYA" GC 3805 BRT

$$= 5,733 \text{ mm} \approx 10 \text{ mm}$$

$$\begin{aligned} t_{\min} &= 5,5 + 0,02 L \\ &= 5,5 + (0,02 \times 98,68) \\ &= 7,473 \text{ mm} \approx 7,5 \text{ mm} \end{aligned}$$

C. KONSTRUKSI DASAR GANDA

C.1. Secara umum

- Pada kapal cargo, dasar ganda terletak antara sekat tubrukan dengan sekat buritan
- Dalam tangki ceruk haluan dan ceruk buritan tidak perlu dipasang alas ganda.

C.2. Penumpu Tengah (Centre Girder)

- Penumpu tengah harus kedap air, sekurang-kurangnya 0,5 L tengah kapal jika dasar gandan tidak dibagi kedap air oleh penumpu samping.
- Penumpu tengah pada 0,75 L di tengah kapal tidak boleh kurang dari :

(Ref : BKI Th. 2006 Sec. 8.B.2.2)

- Tinggi Penumpu tengah

$$\begin{aligned} h &= 350 + 45 \times B & h_{\min} &= 600 \text{ mm} \\ &= 350 + 45 \times 16,33 \end{aligned}$$

$$h = 1084,85 \text{ mm} \approx 1100 \text{ mm}$$

- Tebal penumpu tengah

$$\begin{aligned} t &= (h/100 + 1,0) \sqrt{tk} \\ &= (1100/100 + 1,0) \sqrt{1} \\ &= 12 \text{ mm} \end{aligned}$$

untuk 0,15 L pada ujung kapal, tebal penumpu tengah ditambah 10%.

$$\begin{aligned} t &= 12 + 10\% \times 12 \\ &= 13,2 \text{ mm} \approx 13,5 \text{ mm} \end{aligned}$$

C.3. Penumpu samping (Side Girder)

PROFILE CONSTRUCTION

TUGAS AKHIR KM “BAHARI JAYA” GC 3805 BRT

- a. Penumpu samping (S.G) sekurang-kurangnya dipasang dalam kamar mesin dan 0,25 L, bagian haluan. Satu penumpu samping dipasang apabila lebar horizontal dari sisi bawah plat tepi ke penumpu tengah > dari 4,5 m. Karena nilai $0,5B = 8,165$ maka dipasang 2 penumpu samping.

- b. Tebal penumpu samping tidak boleh kurang dari :

(Ref : BKI Th. 2006 Sec. 8.B.3.2)

$$\begin{aligned}t &= \left[\frac{h^2}{120 \times h} \right] \cdot \sqrt{k} \quad (\text{mm}) \\ &= \left[\frac{1100^2}{120 \times 1100} \right] \cdot \sqrt{1} \\ &= \mathbf{9,166 \text{ mm} \approx 10 \text{ mm}}\end{aligned}$$

untuk 0,15 L pada ujung kapal, tebal penumpu samping ditambah 10%.

$$\begin{aligned}t &= 10 + (10\% \times 10) \\ &= \mathbf{11 \text{ mm}}\end{aligned}$$

- c. Alas dalam

Tebal plat alas dalam (inner Bottom) tidak boleh kurang dari :

$$t = 1,1 \times a \sqrt{P \times k} + t_k$$

(Ref : BKI Th. 2006 Sec. 8.B.4.1)

Dimana :

P = Beban alas dalam (inner bottom, midship)

$$= 67,854 \quad \text{KN/m}^2$$

jadi,

$$\begin{aligned}t_B &= 1,1 \times 0,62 \times \sqrt{67,854 \times 1} + 1,5 \\ &= \mathbf{7,11 \text{ mm} \approx 7,5 \text{ mm}}\end{aligned}$$

C.4. Alas Ganda Sebagai Tangki

Tangki bahan bakar dan minyak lumas :

- a. Tangki alas ganda boleh digunakan untuk mengangkut minyak guna keperluan kapal yang titik nyalanya dibawah 60° C, tangki ini dipisahkan oleh cofferdam.
- b. Tangki minyak lumas, tangki buang, dan tangki sirkulasi harus dipisahkan oleh cofferdam.
- c. Minyak buang dan tangki sirkulasi minyak harus dibuat sedapat mungkin dipisahkan dari kulit kapal.
- d. Penumpu tengah harus dibuat kedap dan sempit diujung kapal jika alas ganda pada tempat tersebut tidak melebihi 4 m.
- e. Papan diatas alas ganda harus ditekan langsung diatas gelar-gelar guna mendapatkan celah untuk aliran air.

C.5. Dasar Ganda Dalam, Sistem Gading Melintang

a. Wrang alas penuh (Solid Floor)

- 1) Dianjurkan untuk memasang wrang pada setiap gading dimana sistem gadingnya adalah :
 - a) Dibagian penguat alas haluan
 - b) Didalam kamar mesin
 - c) Dibawah ruang muat
 - d) Pondasi Ketel
- 2) Wrang alas penuh harus dipasang sekat melintang di bawah topang ruang muat.
 - 1) Dibagian lain D.G. jarak terbesar wrang alas penuh tidak boleh kurang dari 2,4 m untuk kapal $L \leq 100$ m
 - 2) Tebal wrang alas penuh

Tidak boleh kurang dari :

(Ref : BKI Th. 2006 Sec. 8.B.6.2)

$$T_{pf} = (t_m - 2)\sqrt{k}$$

t_m = tebal centre girder

$$= (12 - 2)\sqrt{1}$$

PROFILE CONSTRUCTION

TUGAS AKHIR KM "BAHARI JAYA" GC 3805 BRT

$$= 10 \text{ mm}$$

3) Lubang peringan

$$\begin{aligned} \text{a) Panjang max} &= 0,75 \times h \\ &= 0,75 \times 1100 \\ &= 825 \text{ mm} \end{aligned}$$

$$\text{Direncanakan} = 800 \text{ mm}$$

$$\begin{aligned} \text{b) Tinggi max} &= 0,5 \times h \\ &= 0,5 \times 1100 \\ &= 550 \text{ mm} \end{aligned}$$

$$\text{Direncanakan} = 500 \text{ mm}$$

$$\begin{aligned} \text{c) Diameter} &= 1/3 \times 1100 \\ &= 366,6 \text{ mm} \end{aligned}$$

$$\text{Direncanakan} = 360 \text{ mm}$$

d) Jarak max. Lubang peringan dari penumpu tengah dan plat tepi tidak boleh melebihi dari 0,4 tinggi penumpu tengah.

b. Wrang Alas Kedap Air

1) Tebal dari wrang alas kedap air tidak boleh kurang dari wrang alas penuh = 11 mm

2) Ukuran Stiffener pada wrang kedap air :

$$W = 0,55 \times k \times a \times l^2 \times P$$

(Ref: BKI Th. 2006 Sec. 8.B.6.4.3)

Dimana :

$$\begin{aligned} l &= h_{DB} - 50 \\ &= 1100 - 50 \\ &= 1050 \text{ mm} \end{aligned}$$

$$\begin{aligned} a &= \text{jarak antar stiffener} \\ &= 0,625 \text{ m} \end{aligned}$$

$$n = 0,55 \text{ jika } P = P_i$$

$$k = 1,0$$

$$PB = 88,657 \text{ KN/m}^2$$

Jadi,

$$W = 0,55 \times 1,0 \times 0,625 \times (1,050)^2 \times 88,657$$

$$= 36,39 \text{ cm}^2$$

$$L = 65 \times 50 \times 9$$

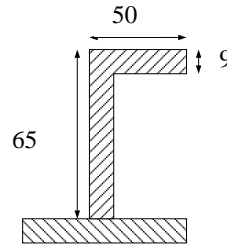

c. **Wrang alas terbuka**

Wrang alas terbuka terdiri dari gading-gading pada plat dasar dan gading balik pada plat alas dalam yang dihubungkan pada penumpu tengah dan plat tepi melalui plat penunjang.

Modulus penampang gading-gading alas tidak boleh kurang dari :

$$W = n \times c \times a \times l^2 \times P \times k \quad (\text{cm}^3)$$

(Ref : BKI Th. 2006 Sec. 8.B.6.4.3)

1) Untuk gading balik

$$P = 88,657 \text{ KN/m}^2$$

l = Panjang tak ditumpu

$$= 3,125 - (0,75 \times h_{DB})$$

$$= 3,125 - (0,75 \times 1,1)$$

$$= 2,3 \text{ m}$$

$$n = 0,55$$

$$c = 0,65$$

$$k = 1$$

$$a = 0,625 \text{ m}$$

$$W = 0,55 \times 0,65 \times 0,625 \times 88,657 \times (2,3)^2 \times 1,0$$

$$= 104,79 \text{ cm}^3$$

Profil perencanaan (L) = 100 × 75 × 11

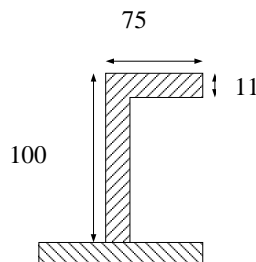

2) Gading alas

$$P = 88,657 \text{ KN/m}^2$$

l = Panjang tak ditumpu

$$= 3,125 - (0,75 \times h_{DB})$$

$$= 3,125 - (0,75 \times 1,1)$$

$$= 2,3 \text{ m}$$

$$n = 0,7$$

$$c = 0,65$$

$$k = 1$$

$$a = 0,625$$

$$W = 0,7 \times 0,65 \times 0,625 \times (2,3)^2 \times 88,657 \text{ 1,0}$$

$$= 128,023 \text{ KN/m}^3$$

Profil perencanaan (L) = $120 \times 80 \times 10$
80

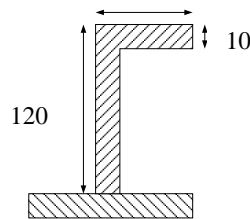

C.6. Konstruksi alas ganda pada kamar mesin

Tinggi Alas Ganda pada Kamar Mesin

Dasar ganda Ruang Mesin ditambah 20 % h_{DB} (ht) :

$$ht = (20\% \times 1100) + 1100$$

$$= 1320 \text{ mm}$$

a. Tebal plat penumpu memanjang (pondasi mesin)

(Ref : BKI Th. 2006 Sec. 8.C.3.2.1)

Tebal plat pondasi mesin tidak boleh kurang dari :

$$t = \frac{P}{750} + 14 \quad (\text{mm})$$

$$P = \text{daya mesin} \times 0,7355$$

$$= 3800 \times 0,7355$$

PROFILE CONSTRUCTION

TUGAS AKHIR KM "BAHARI JAYA" GC 3805 BRT

$$P = 2794,9 \text{ kW}$$

$$t = \frac{2794,9}{750} + 14$$

$$= 17,727 \approx \text{diambil } 18 \text{ mm}$$

b. Tebal Top Plate

(Ref : BKI Th. 2006 Sec. 8.C.3.2.3)

$$A_r = \frac{P}{75} + 70 = \frac{2794,9}{75} + 70$$

$$= 107,265 \text{ cm}^2$$

Lebar Top Plate antara 200 s/d 400, diambil 400 mm

$$\text{Jadi tebal top plate} = \frac{A_r}{400}$$

$$= \frac{107,265}{400}$$

$$= 0,268 \text{ cm} = 26,8 \text{ mm} \approx \text{diambil } 30 \text{ mm}$$

c. Tebal wrang alas penuh pada daerah kamar mesin diperkuat sebesar

(Ref : BKI Th. 2006 Sec. 8.C.2.2)

$$t = 3,6 + \frac{P}{500} (\%)$$

$$= 3,6 + \frac{2794,9}{500} (\%)$$

$$t = 9,190 \%$$

$$t = 10 \text{ mm} + (9,190 \% \times 10) \text{ mm}$$

$$= 10,919 \text{ mm} \approx 11 \text{ mm}$$

D. PERHITUNGAN GADING-GADING

Jarak Gading Normal

- Menurut BKI Th. 2006 jarak gading normal antara 0,2 L dari FP sampai sekat ceruk buritan adalah tidak boleh kurang dari 600 mm
- Di depan sekat tubrukan dan di belakang sekat ceruk buritan jarak gading normal maksimal 600 mm

$$\begin{aligned}
 a &= \frac{L}{500} + 0,48 \\
 &= \frac{98,68}{500} + 0,48 \\
 &= 0,67 \text{ m} \approx \text{diambil } 0,62 \text{ m}
 \end{aligned}$$

D.1. Gading-gading utama pada kapal

Modulus gading utama tidak boleh kurang dari :

$$\begin{aligned}
 W &= n \times c \times a \times l^2 \times Ps \times Cr \times k \text{ (cm}^3\text{)} \\
 &\text{(Ref : BKI Th. 2006 Sec. 9.A.2.1.1)}
 \end{aligned}$$

Dimana :

$$\begin{aligned}
 k &= 1 \\
 n &= 0,55 \quad \text{Untuk } L \geq 100 \text{ m} \\
 a &= \text{jarak antar gading} \\
 &= 0,6 \text{ m (pada AP – fr 10)} \\
 &= 0,62 \text{ m (pada fr. 10 – fr. 144)} \\
 &= 0,6 \text{ m (pada fr. 144 – fr. 160)} \\
 l &= \text{panjang tak ditumpu} \\
 &= 1/3 (H – h) \\
 &= 1/3 (8,81 – 1,1) \\
 &= 2,57 \text{ m} \\
 Ps_1 &= 87,36 \text{ KN/ m}^2 \text{ (untuk Buritan kapal)} \\
 Ps_2 &= 70,54 \text{ KN/ m}^2 \text{ (untuk Midship Kapal)} \\
 Ps_3 &= 106,14 \text{ KN/ m}^2 \text{ (untuk Haluan Kapal)} \\
 Cr_{\min} &= 0,75 \\
 k &= 1,0 \\
 c_{\min} &= 0,6
 \end{aligned}$$

Jadi :

$$\begin{aligned}
 \text{a. Modulus gading utama pada daerah buritan } a &= 0,6 \text{ m} \\
 W &= 0,55 \times 0,6 \times 0,6 \times (2,57)^2 \times 87,36 \times 0,75 \times 1,0 \\
 &= \mathbf{105,24 \text{ cm}^3}
 \end{aligned}$$

Profil yang direncanakan = L 130 × 75 × 8

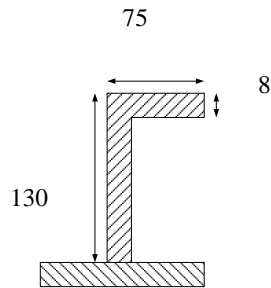

- b. Modulus gading utama pada daerah buritan $a = 0,62$ m

$$W = 0,55 \times 0,6 \times 0,62 \times (2,57)^2 \times 87,36 \times 0,75 \times 1,0$$

$$= 108,75 \text{ cm}^3$$

Profil yang direncanakan = L $\frac{130 \times 65 \times 10}{65}$

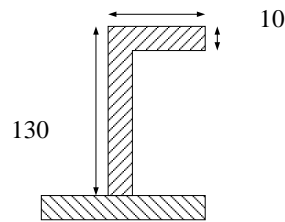

- c. Modulus gading utama pada daerah midship $a = 0,62$ m

$$W = 0,55 \times 0,6 \times 0,62 \times (2,57)^2 \times 70,54 \times 0,75 \times 1,0$$

$$= 95,138 \text{ cm}^3$$

Profil yang direncanakan = L $\frac{130 \times 65 \times 8}{65}$

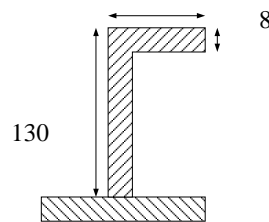

- d. Modulus penampang gading pada gading utama bagian haluan kapal $a = 0,62$ m

$$W = 0,55 \times 0,6 \times 0,62 \times (2,57)^2 \times 106,14 \times 0,75 \times 1,0$$

$$= 132,133 \text{ cm}^3$$

Profil yang direncanakan = L $130 \times 75 \times 10$

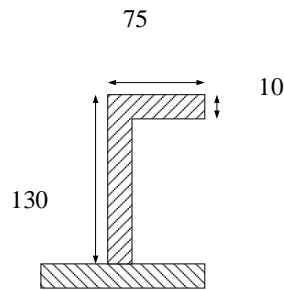

- e. Modulus penampang gading pada gading utama bagian haluan kapal $a = 0,6$ m

$$W = 0,55 \times 0,6 \times 0,6 \times (2,57)^2 \times 106,14 \times 0,75 \times 1,0$$

$$= 127,870 \text{ cm}^3$$

Profil yang direncanakan = **L 120 × 80 × 10**
80

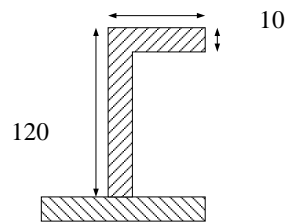

D.2. Gading-gading bangunan atas & rumah geladak

Modulus gading bangunan atas tidak boleh kurang dari:

(Ref : BKI Th. 2006 Sec. 9.A.3.2)

a. Poop Deck

$$W = 0,55 \times a \times l^2 \times Ps \times Cr \times k \text{ (cm}^3\text{)}$$

Dimana :

$$a = 0,62 \text{ m}$$

$$l = \text{panjang tak ditumpu}$$

$$= 2,2 \text{ m (jarak antar geladak)}$$

$$Ps = 46,656 \text{ KN/m}^2$$

$$Cr = 0,75$$

$$k = 1,0$$

$$W = 0,55 \times 0,62 \times (2,2)^2 \times 46,656 \times 0,75 \times 1,0$$

$$= 62,565 \text{ cm}^3$$

PROFILE CONSTRUCTION

TUGAS AKHIR KM "BAHARI JAYA" GC 3805 BRT

Profil yang direncanakan = L 80 × 65 × 8

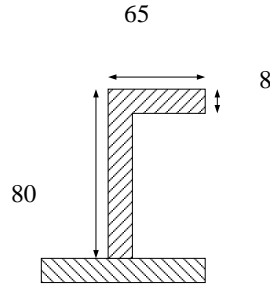

b. Boat Deck

$$W = 0,55 \times a \times l^2 \times ps \times Cr \times k \quad (\text{cm}^3)$$

Dimana :

$$a = 0,62 \text{ m}$$

$$l = \text{panjang tak ditumpu} \\ = 2,2 \text{ m (jarak antar geladak)}$$

$$Ps = 42,953 \text{ KN/m}^2$$

$$Cr = 0,75$$

$$k = 1,0$$

$$W = 0,55 \times 0,62 \times (2,2)^2 \times 42,953 \times 0,75 \times 1,0 \\ = 57,60 \text{ cm}^3$$

Profil yang direncanakan = L 90 × 75 × 7

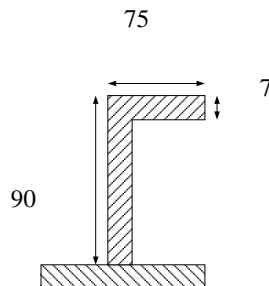

c. Navigation Deck

$$W = 0,55 \times a \times l^2 \times Ps \times Cr \times k \quad (\text{cm}^3)$$

Dimana :

$$a = 0,62 \text{ m}$$

$$l = \text{panjang tak ditumpu} \\ = 2,2 \text{ m (jarak antar geladak)}$$

PROFILE CONSTRUCTION

TUGAS AKHIR KM "BAHARI JAYA" GC 3805 BRT

$$P_s = 39,795 \text{ KN/m}^2$$

$$C_r = 0,75$$

$$k = 1,0$$

$$W = 0,55 \times 0,62 \times (2,2)^2 \times 39,795 \times 0,75 \times 1,0 \\ = 53,364 \text{ cm}^3$$

Profil yang direncanakan = L 90 × 60 × 8

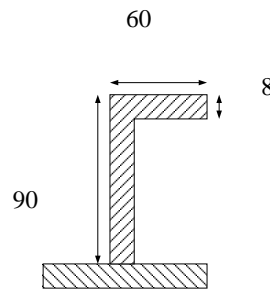

d. Compass Deck

$$W = 0,55 \times a \times l^2 \times P_s \times C_r \times k \quad (\text{cm}^3)$$

Dimana :

$$a = 0,62 \text{ m}$$

$$l = \text{panjang tak ditumpu} \\ = 2,2 \text{ m (jarak antar geladak)}$$

$$P = 37,795 \text{ KN/m}^2$$

$$C_r = 0,75$$

$$k = 1,0$$

$$W = 0,55 \times 0,62 \times (2,2)^2 \times 37,795 \times 0,75 \times 1,0 \\ = 49,70 \text{ cm}^3$$

Profil yang direncanakan = L 80 × 65 × 8

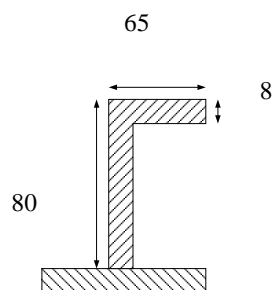

e. Fore Castle Deck

$$W = 0,55 \times a \times l^2 \times P_s \times C_r \times k \quad (\text{cm}^3)$$

PROFILE CONSTRUCTION

TUGAS AKHIR KM “BAHARI JAYA” GC 3805 BRT

Dimana :

$$a = 0,62 \text{ m}$$

$$l = \text{panjang tak ditumpu} \\ = 2,2 \text{ m (jarak antar geladak)}$$

$$P = 68,734 \text{ KN/m}^2$$

$$Cr = 0,75$$

$$k = 1,0$$

$$W = 0,55 \times 0,62 \times (2,2)^2 \times 68,734 \times 0,75 \times 1,0 \\ = 85,08 \text{ cm}^3$$

Profil yang direncanakan = **L 100 × 75 × 9**

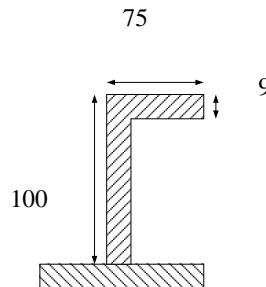

f. Winch Deck

$$W = 0,55 \times a \times l^2 \times Ps \times Cr \times k \quad (\text{cm}^3)$$

Dimana :

$$l = \text{panjang tak ditumpu} \\ = 2,2 \text{ m (jarak antar geladak)}$$

$$P = 17,234 \text{ KN/m}^2$$

$$Cr = 0,75$$

$$k = 1,0$$

$$W = 0,55 \times 0,62 \times (2,2)^2 \times 17,234 \times 0,75 \times 1,0 \\ = 22,365 \text{ cm}^3$$

Profil yang direncanakan = **L 75 × 50 × 5**

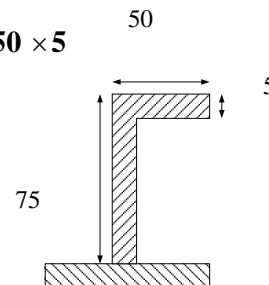

D.3. Gading-gading besar (web frame)

Modulus gading Besar tidak boleh kurang dari :

(Ref : BKI Th. 2006 Sec. 9.A.5.3)

$$W = 0,55 \times e \times l^2 \times P_s \times n \times k$$

Dimana :

$$\begin{aligned} a &= \text{jarak antar gading} \\ &= 0,6 \text{ m (pada AP - fr 10)} \\ &= 0,62 \text{ m (pada fr. 10 - fr. 144)} \\ &= 0,6 \text{ m (pada fr. 144 - fr. 160)} \end{aligned}$$

$$\begin{aligned} e &= 3 \times a \\ &= 3 \times 0,62 = 2,86 \text{ m} \quad \text{untuk } a = 0,62 \end{aligned}$$

$$\begin{aligned} l &= 1/3 (H - h_{db}) \\ &= 1/3 (8,81 - 1,1) \\ &= 2,57 \text{ m} \end{aligned}$$

$$P_{s1} = 79,42 \text{ kN / m}^2$$

$$P_{s2} = 65,97 \text{ kN / m}^2$$

$$P_{s3} = 94,44 \text{ kN / m}^2$$

$$n = 1,0$$

$$k = 1,0$$

Jadi,

- 1) Modulus & perencanaan profil penampang gading besar pada daerah buritan a = 0,6 m

$$\begin{aligned} W &= 0,55 \times 1,86 \times (2,57)^2 \times 79,42 \times 1,0 \times 1,0 \\ &= 535,202 \text{ kN / m}^2 \end{aligned}$$

Profil yang direncanakan **T 250 × 12 FP 110 × 12**

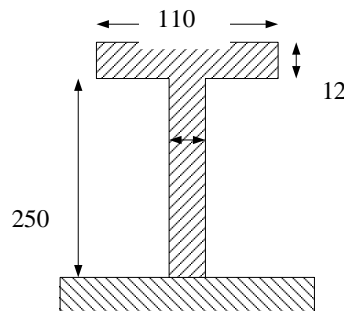

Koreksi modulus :

$$\text{Lebar berguna } (40 - 50) = 50 \text{ cm}$$

$$f = 11 \times 1,2 = 13,2 \text{ cm}^2$$

$$f_s = 25 \times 1,2 = 30 \text{ cm}^2$$

$$F = 50 \times 1,2 = 60 \text{ cm}^2$$

$$f/F = 0,22$$

$$f_s/F = 0,5$$

$$w = 0,36$$

$$\begin{aligned} W &= w \times F \times h \\ &= 0,36 \times 60 \times 25 \\ &= 540 \text{ cm}^3 \end{aligned}$$

W rencana > W perhitungan

$$540 > 535,202 \quad (\text{memenuhi})$$

2) Modulus & perencanaan profil penampang gading besar pada daerah midship $a = 0,62 \text{ m}$

$$P_{s2} = 65,97 \text{ kN / m}^2$$

$$\begin{aligned} W &= 0,55 \times 1,86 \times (2,57)^2 \times 65,97 \times 1,0 \times 1,0 \\ &= 430,21 \text{ kN / m}^2 \end{aligned}$$

Profil yang direncanakan **T 240 × 11 FP 110 × 11**
110

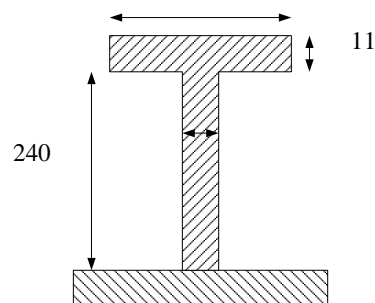

Koreksi modulus :

$$\text{Lebar berguna } (40 - 50) = 50$$

PROFILE CONSTRUCTION

TUGAS AKHIR KM "BAHARI JAYA" GC 3805 BRT

$$f = 11 \times 1,1 = 12,1 \text{ cm}^2$$

$$f_s = 24 \times 1,1 = 26,4 \text{ cm}^2$$

$$F = 50 \times 1,0 = 50 \text{ cm}^2$$

$$f/F = 0,24$$

$$f_s/F = 0,53$$

$$w = 0,36$$

$$\begin{aligned} W &= w \times F \times h \\ &= 0,36 \times 50 \times 24 \\ &= 432 \text{ cm}^3 \end{aligned}$$

W rencana > W perhitungan

$$432 > 430,21 \quad (\text{memenuhi})$$

- 3) Modulus & perencanaan profil penampang gading besar pada daerah haluan $a = 0,62 \text{ m}$

$$P_{s3} = 94,44 \text{ kN / m}^2$$

$$\begin{aligned} W &= 0,55 \times 1,86 \times (2,57)^2 \times 94,44 \times 1,0 \times 1,0 \\ &= 620,45 \text{ kN / m}^2 \end{aligned}$$

Profil yang direncanakan = **T 260 × 13 FP 120 × 13**
120

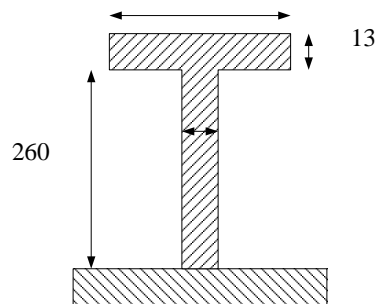

Koreksi modulus :

Lebar berguna $(40 - 50) = 50$

$$f = 12 \times 1,3 = 15,6 \text{ cm}^2$$

$$f_s = 26 \times 1,3 = 33,8 \text{ cm}^2$$

$$F = 50 \times 1,2 = 60 \text{ cm}^2$$

$$f/F = 0,26$$

$$f_s/F = 0,56$$

$$w = 0,40$$

PROFILE CONSTRUCTION

TUGAS AKHIR KM "BAHARI JAYA" GC 3805 BRT

$$\begin{aligned}W &= w \times F \times h \\ &= 0,40 \times 60 \times 26 \\ &= 624 \text{ cm}^3\end{aligned}$$

W rencana > W perhitungan

$$624 > 620,45 \quad (\text{memenuhi})$$

4) Modulus penampang gading besar pada Kamar mesin a = 0,62 m

(Ref: BKI Th. 2006 Sec. 9.A.6.2.1)

$$W = 0,8 \times e \times l^2 \times P_s \times k$$

Dimana ;

$$a = 0,62 \text{ m}$$

$$\begin{aligned}e &= 3 \times a \\ &= 3 \times 0,62 = 1,86 \text{ m}\end{aligned}$$

$$\begin{aligned}l &= 1/3 (H - h_{db} \text{ kamar mesin}) \\ &= 1/3 (8,81 - 1,32) \\ &= 2,49 \text{ m}\end{aligned}$$

$$P_s = 79,42 \text{ kN / m}^2$$

$$\begin{aligned}W &= 0,8 \times 1,86 \times (2,49)^2 \times 79,42 \times 1,0 \\ &= 732,708 \text{ kN / m}^2\end{aligned}$$

Profil yang direncanakan **T = 300 × 14 FP 100 × 14**

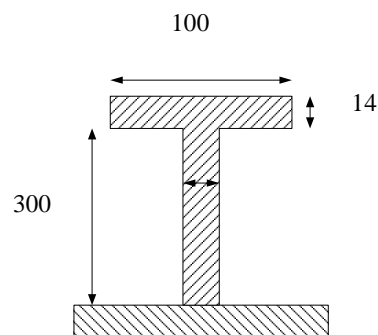

Koreksi modulus :

Lebar berguna (40 – 50) = 50

$$f = 10 \times 1,4 = 14 \text{ cm}^2$$

$$f_s = 30 \times 1,4 = 42 \text{ cm}^2$$

PROFILE CONSTRUCTION

TUGAS AKHIR KM "BAHARI JAYA" GC 3805 BRT

$$F = 50 \times 1,2 = 60 \text{ cm}^2$$

$$f/F = 0,23$$

$$fs/F = 0,7$$

$$w = 0,41$$

$$\begin{aligned} W &= w \times F \times h \\ &= 0,41 \times 60 \times 30 \\ &= 738 \text{ cm}^3 \end{aligned}$$

W rencana > W perhitungan

$$738 > 732,708 \quad (\text{memenuhi})$$

D.4. Modulus Gading besar pada bangunan atas & Rumah geladak :

$$W = 0,55 \times e \times l^2 \times Ps \times n \times k$$

(Ref : BKI Th. 2006 Sec. 9.A.5.3.1)

a) Pada poop deck

$$Ps = 37,325 \text{ KN/m}^2$$

a = jarak antar gading

$$= 0,6 \text{ m (pada AP - fr 10)}$$

$$= 0,62 \text{ m (pada fr. 10 - fr. 144)}$$

$$= 0,6 \text{ m (pada fr. 144 - fr. 160)}$$

$$e = 3 \times a$$

$$= 3 \times 0,6 = 1,8 \text{ m} \quad \text{untuk } a = 0,6$$

$$e = 3 \times a$$

$$= 3 \times 0,62 = 1,86 \text{ m} \quad \text{untuk } a = 0,62$$

l = panjang tak ditumpu

$$= 2,2 \text{ m}$$

Jadi,

Modulus & perencanaan profil penampang gading besar pada poop deck untuk jarak gading $a = 0,62 \text{ m}$:

$$\begin{aligned} W &= 0,55 \times 1,86 \times (2,2)^2 \times 37,325 \times 1,0 \times 1,0 \quad (\text{cm}^3) \\ &= 268,81 \text{ cm}^3 \end{aligned}$$

Profil yang direncanakan **T 210 × 9 FP 90 × 9**

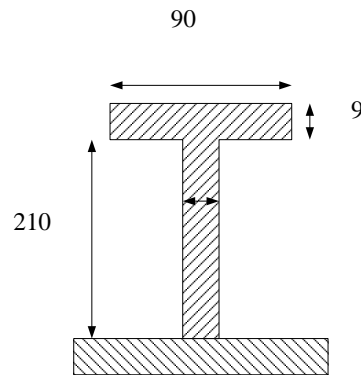

Koreksi modulus :

Lebar berguna (40 – 50) = 50

$$f = 9 \times 0,9 = 8,1 \text{ cm}^2$$

$$f_s = 21 \times 0,9 = 18,9 \text{ cm}^2$$

$$F = 50 \times 0,75 = 37,5 \text{ cm}^2$$

$$f/F = 0,22$$

$$f_s/F = 0,50$$

$$w = 0,35$$

$$W = w \times F \times h$$

$$= 0,35 \times 37,5 \times 21$$

$$= 275,63 \text{ cm}^3$$

W rencana > W perhitungan

$$275,63 > 268,81 \quad (\text{memenuhi})$$

b) Pada Boat deck

$$P_s = 34,363 \text{ KN/m}^2$$

$$e = 3 \times a$$

$$= 3 \times 0,62 = 1,86 \text{ m} \quad \text{untuk } a = 0,62$$

Jadi,

Modulus & perencanaan profil penampang gading besar pada boat deck untuk jarak gading (a) = 0,62 m:

$$W = 0,55 \times 1,86 \times (2,2)^2 \times 34,363 \times 1,0 \times 1,0 \quad (\text{cm}^3)$$

$$= 247,94 \text{ cm}^3$$

PROFILE CONSTRUCTION

TUGAS AKHIR KM "BAHARI JAYA" GC 3805 BRT

Profil yang direncanakan T 210 × 9 FP 80 × 9

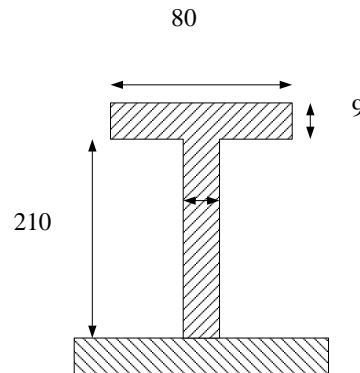

Koreksi modulus :

Lebar berguna (40 – 50) = 50

$$f = 8 \times 0,9 = 7,2 \text{ cm}^2$$

$$f_s = 21 \times 0,9 = 18,9 \text{ cm}^2$$

$$F = 50 \times 0,75 = 37,5 \text{ cm}^2$$

$$f/F = 0,19$$

$$f_s/F = 0,50$$

$$w = 0,32$$

$$\begin{aligned} W &= w \times F \times h \\ &= 0,32 \times 37,5 \times 21 \\ &= 252 \text{ cm}^3 \end{aligned}$$

W rencana > W perhitungan

$$252 > 247,94 \text{ (memenuhi)}$$

c) Navigation Deck

$$P_s = 31,836 \text{ KN/m}^2$$

$$\begin{aligned} e &= 3 \times a \\ &= 3 \times 0,62 = 1,86 \text{ m} \end{aligned}$$

Modulus & perencanaan profil penampang gading besar pada navigation deck a = 0,62 m :

$$\begin{aligned} W &= 0,55 \times 1,86 \times (2,2)^2 \times 31,836 \times 1,0 \times 1,0 \quad (\text{cm}^3) \\ &= 229,280 \text{ cm}^3 \end{aligned}$$

Profil yang direncanakan T 200 × 8 FP 90 × 8

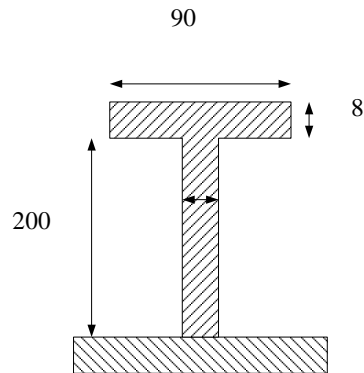

Koreksi modulus :

Lebar berguna (40 – 50) = 50

$$f = 9 \times 0,8 = 7,2 \text{ cm}^2$$

$$f_s = 20 \times 0,8 = 16 \text{ cm}^2$$

$$F = 50 \times 0,9 = 35 \text{ cm}^2$$

$$f/F = 0,21$$

$$f_s/F = 0,46$$

$$w = 0,34$$

$$\begin{aligned} W &= w \times F \times h \\ &= 0,34 \times 35 \times 20 \\ &= 238 \text{ cm}^3 \end{aligned}$$

W rencana > W perhitungan

$$238 > 229,80 \text{ (memenuhi)}$$

d) Compas Deck

$$P_s = 29,665 \text{ KN/m}^2$$

$$\begin{aligned} e &= 3 \times a \\ &= 3 \times 0,62 = 1,86 \text{ m} \end{aligned}$$

Modulus & perencanaan profil penampang gading besar pada compass deck a = 0,62 m:

$$\begin{aligned} W &= 0,55 \times 1,86 \times (2,2)^2 \times 29,665 \times 1,0 \times 1,0 \quad (\text{cm}^3) \\ &= 213,57 \text{ cm}^3 \end{aligned}$$

Profil yang direncanakan **T 200 × 8 FP 80 × 8**

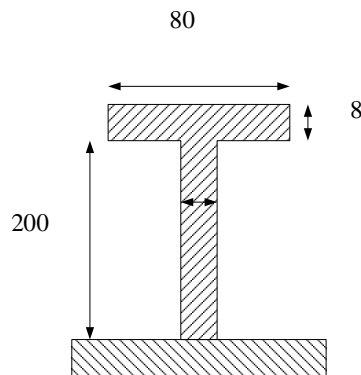

Koreksi modulus :

Lebar berguna (40 – 50) = 50

$$f = 8 \times 0,8 = 6,4 \text{ cm}^2$$

$$f_s = 20 \times 0,8 = 16 \text{ cm}^2$$

$$F = 50 \times 0,7 = 35 \text{ cm}^2$$

$$f/F = 0,18$$

$$f_s/F = 0,46$$

$$w = 0,31$$

$$\begin{aligned} W &= w \times F \times h \\ &= 0,31 \times 35 \times 20 \\ &= 217 \text{ cm}^3 \end{aligned}$$

W rencana > W perhitungan

$$217 > 213,57 \text{ (memenuhi)}$$

e) Fore Castle Deck

$$P_s = 54,987 \text{ KN/m}^2$$

$$e = 3 \times a$$

$$= 3 \times 0,62 = 1,86 \text{ m} \text{ untuk } a = 0,62$$

Jadi,

Modulus & perencanaan profil penampang gading besar pada fore castle deck untuk jarak gading $a = 0,62 \text{ m}$:

$$\begin{aligned} W &= 0,55 \times 1,86 \times (2,2)^2 \times 54,987 \times 1,0 \times 1,0 \quad (\text{cm}^3) \\ &= 396,01 \text{ cm}^3 \end{aligned}$$

PROFILE CONSTRUCTION

TUGAS AKHIR KM "BAHARI JAYA" GC 3805 BRT

Profil yang direncanakan **T 240 × 10 FP 100 × 10**

100

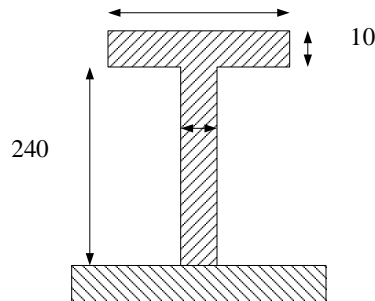

Koreksi modulus :

Lebar berguna $(40 - 50) = 50$

$$f = 10 \times 1,0 = 10 \text{ cm}^2$$

$$f_s = 24 \times 1,0 = 24 \text{ cm}^2$$

$$F = 50 \times 0,9 = 45 \text{ cm}^2$$

$$f/F = 0,22$$

$$f_s/F = 0,53$$

$$w = 0,37$$

$$W = w \times F \times h$$

$$= 0,37 \times 45 \times 24$$

$$= 399,6 \text{ cm}^3$$

W rencana > W perhitungan

$$399,6 > 396,01 \quad (\text{memenuhi})$$

f) Winch Deck

$$P_s = 13,787 \text{ KN/m}^2$$

$$e = 3 \times a$$

$$= 3 \times 0,62 = 1,86 \text{ m}$$

Jadi,

Modulus & perencanaan profil penampang gading besar pada

Winch deck $a = 0,62 \text{ m}$:

$$W = 0,55 \times 1,86 \times (2,2)^2 \times 13,787 \times 1,0 \times 1,0 \quad (\text{cm}^3)$$

$$= 99,29 \text{ cm}^3$$

Profil yang direncanakan **T 140 × 8 FP 60 × 8**

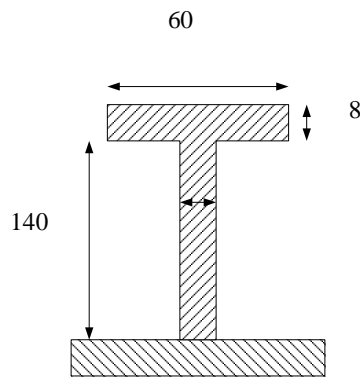

Koreksi modulus :

Lebar berguna $(40 - 50) = 50$

$$f = 6 \times 0,8 = 4,8 \text{ cm}^2$$

$$f_s = 14 \times 0,8 = 11,2 \text{ cm}^2$$

$$F = 50 \times 0,7 = 3,5 \text{ cm}^2$$

$$f/F = 0,14$$

$$f_s/F = 0,32$$

$$w = 0,22$$

$$\begin{aligned} W &= w \times F \times h \\ &= 0,22 \times 35 \times 14 \\ &= 107,8 \text{ cm}^3 \end{aligned}$$

W rencana > W perhitungan

$$107,8 > 99,29 \text{ (memenuhi)}$$

E. PERHITUNGAN SENTA SISI

Modulus senta sisi tidak boleh kurang dari :

$$W = 0,55 \times e \times l^2 \times P_s \times n \times k$$

(Ref : BKI Th. 2006 Sec. 9.A.5.3)

Dimana :

$$k = 1,0$$

$$n = 1,0$$

e = lebar pembebanan

$$= 1/3 (H - h)$$

$$= 1/3 (8,81 - 1,32)$$

$$= 2,49 \text{ m}$$

(pada daerah kamar mesin)

e = lebar pembebanan

PROFILE CONSTRUCTION

TUGAS AKHIR KM "BAHARI JAYA" GC 3805 BRT

$$\begin{aligned} &= 1/3 (H - h) \\ &= 1/3 (8,81 - 1,1) \\ &= 2,57 \text{ m} \quad (\text{pada daerah midship \& haluan}) \\ P_{s1} &= 87,36 \quad \text{KN/ m}^2 \quad (\text{Untuk daerah buritan kapal}) \\ P_{s2} &= 70,54 \quad \text{KN/ m}^2 \quad (\text{Untuk daerah tengah kapal}) \\ P_{s3} &= 106,14 \quad \text{KN/ m}^2 \quad (\text{Untuk daerah haluan kapal}) \\ l &= \text{panjang tak di tumpu} \\ &= 3 \times a \\ &= 3 \times 0,62 = 1,86 \text{ m} \end{aligned}$$

Jadi :

a. Modulus senta sisi pada daerah buritan (pada kamar mesin)

$$\begin{aligned} W &= 0,55 \times 2,49 \times (1,86)^2 \times 87,36 \times 1,0 \times 1,0 \quad (\text{cm}^3) \\ &= 564,112 \text{ cm}^3 \end{aligned}$$

Profil yang direncanakan = **T 250 × 13 FP 110 × 13**

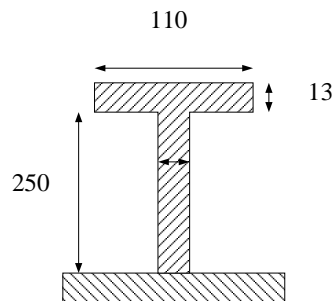

Koreksi modulus :

Lebar berguna $(40 - 50) = 50$

$$f = 11 \times 1,3 = 14,3 \text{ cm}^2$$

$$f_s = 25 \times 1,3 = 32,5 \text{ cm}^2$$

$$F = 50 \times 1,2 = 60 \text{ cm}^2$$

$$f/F = 0,24$$

$$f_s/F = 0,54$$

$$w = 0,38$$

$$\begin{aligned} W &= w \times F \times h \\ &= 0,38 \times 60 \times 25 \\ &= 570 \text{ cm}^3 \end{aligned}$$

W rencana > W perhitungan

PROFILE CONSTRUCTION

TUGAS AKHIR KM “BAHARI JAYA” GC 3805 BRT

$$570 > 564,112 \quad (\text{memenuhi})$$

b. Modulus senta sisi pada daerah midship

$$\begin{aligned} W &= 0,55 \times 2,57 \times (1,86)^2 \times 70,54 \times 1,0 \times 1,0 \quad (\text{cm}^3) \\ &= 501,29 \text{ cm}^3 \end{aligned}$$

Profil yang direncanakan **T 240 × 12 FP 110 × 12**

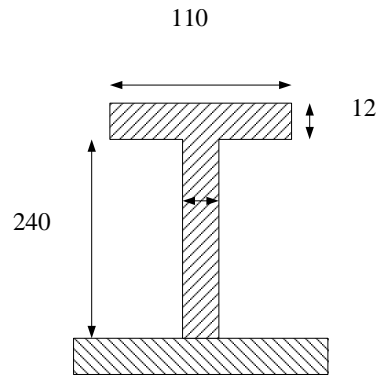

Koreksi modulus :

Lebar berguna $(40 - 50) = 50$

$$f = 11 \times 1,2 = 13,2 \text{ cm}^2$$

$$f_s = 24 \times 1,2 = 28,8 \text{ cm}^2$$

$$F = 50 \times 1,0 = 50 \text{ cm}^2$$

$$f/F = 0,26$$

$$f_s/F = 0,58$$

$$w = 0,42$$

$$\begin{aligned} W &= w \times F \times h \\ &= 0,42 \times 50 \times 24 \\ &= 504 \text{ cm}^3 \end{aligned}$$

W rencana > W perhitungan

$$504 > 501,29 \quad (\text{memenuhi})$$

c. Modulus penampang senta sisi pada haluan kapal :

$$\begin{aligned} W &= 0,55 \times 2,57 \times (1,86)^2 \times 106,14 \times 1,0 \times 1,0 \quad (\text{cm}^3) \\ &= 731,33 \text{ cm}^3 \end{aligned}$$

Profil yang direncanakan = **T 260 × 15 FP 120 × 15**

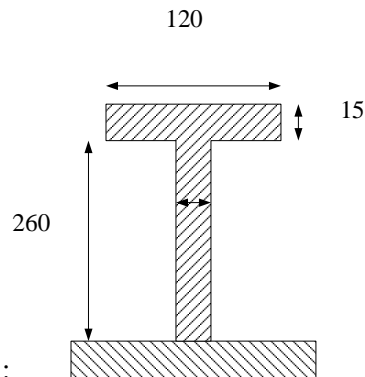

Koreksi modulus :

Lebar berguna $(40 - 50) = 50$

$$f = 12 \times 1,5 = 18 \text{ cm}^2$$

$$f_s = 26 \times 1,5 = 39 \text{ cm}^2$$

$$F = 50 \times 1,2 = 60 \text{ cm}^2$$

$$f/F = 0,3$$

$$f_s/F = 0,65$$

$$w = 0,47$$

$$\begin{aligned} W &= w \times F \times h \\ &= 0,47 \times 60 \times 28 \\ &= 733,2 \text{ cm}^3 \end{aligned}$$

W rencana > W perhitungan

$$733,2 > 731,33 \text{ (memenuhi)}$$

F. PERHITUNGAN BALOK GELADAK

F.1. Balok geladak (Deck beam)

a. Modulus penampang balok geladak melintang tidak boleh kurang dari:

$$W = c \times a \times P_d \times l^2 \times k \quad (\text{cm}^3)$$

(Ref : BKI Th. 2006 Sec. 10.B.1)

dimana :

$$c = 0,75 \quad \text{untuk Beam}$$

a = jarak antar gading

$$= 0,6 \text{ m (pada AP - fr 10)}$$

$$= 0,62 \text{ m (pada fr. 10 - fr. 144)}$$

$$= 0,6 \text{ m (pada fr. 144 - fr. 160)}$$

PROFILE CONSTRUCTION

TUGAS AKHIR KM "BAHARI JAYA" GC 3805 BRT

$$P_{D1} = 26,27 \quad \text{KN/m}^2 \quad \text{untuk Buritan kapal}$$

$$P_{D2} = 23,88 \quad \text{KN/m}^2 \quad \text{untuk Midship kapal}$$

$$P_{D3} = 33,04 \quad \text{KN/m}^2 \quad \text{untuk Haluan kapal}$$

l = Panjang tak ditumpu

$$= 3,125 \text{ m}$$

$$k = 1,0$$

1) Modulus penampang deck beam pada buritan kapal $a = 0,6 \text{ m}$

$$\begin{aligned} W &= 0,75 \times 0,6 \times 26,27 \times (3,125)^2 \times 1,0 \quad (\text{cm}^3) \\ &= 115,43 \text{ cm}^3 \end{aligned}$$

Profil yang direncanakan L 130 × 65 × 10

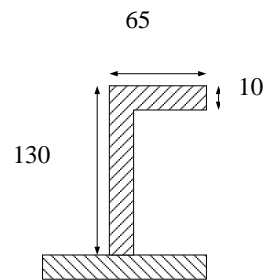

2) Modulus penampang deck beam pada buritan kapal $a = 0,62 \text{ m}$

$$\begin{aligned} W &= 0,75 \times 0,62 \times 26,27 \times (3,125)^2 \times 1,0 \quad (\text{cm}^3) \\ &= 119,285 \text{ cm}^3 \end{aligned}$$

Profil yang direncanakan L 130 × 65 × 10

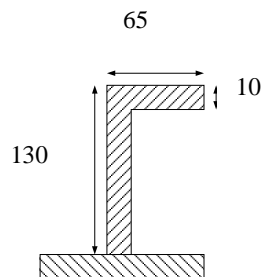

3) Modulus penampang deck beam pada Midship kapal $a = 0,62 \text{ m}$

PROFILE CONSTRUCTION

TUGAS AKHIR KM "BAHARI JAYA" GC 3805 BRT

$$W = 0,75 \times 0,62 \times 23,88 \times (3,125)^2 \times 1,0 \quad (\text{cm}^3)$$
$$= 108,435 \text{ cm}^3$$

Profil yang direncanakan L 130 × 75 × 8

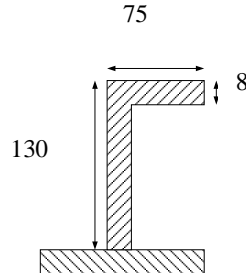

4) Modulus penampang deck beam pada haluan kapal a = 0,62 m

$$W = 0,75 \times 0,62 \times 33,04 \times (3,125)^2 \times 1,0 \quad (\text{cm}^3)$$
$$= 150,013 \text{ cm}^3$$

Profil yang direncanakan L 130 × 90 × 10

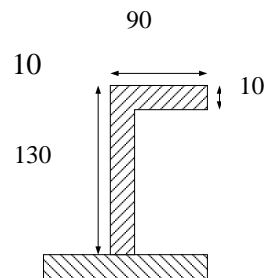

5) Modulus penampang deck beam pada haluan kapal a = 0,6 m

$$W = 0,75 \times 0,6 \times 33,04 \times (3,125)^2 \times 1,0 \quad (\text{cm}^3)$$
$$= 145,182 \text{ cm}^3$$

Profil yang direncanakan L 130 × 65 × 12

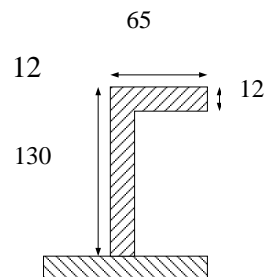

b. Balok geladak bangunan atas

Modulus balok geladak bangunan atas :

$$W = c \times a \times P \times l^2 \times k \quad (\text{cm}^3)$$

PROFILE CONSTRUCTION

TUGAS AKHIR KM "BAHARI JAYA" GC 3805 BRT

(Ref : BKI Th. 2006 Sec. 10.B.1)

1) Modulus Deck Beam pada geladak kimbul (Poop Deck)

$$c = 0,75$$

a = jarak gading

$$= 0,62 \text{ m}$$

l = panjang tak ditumpu

$$= 3,125 \text{ m}$$

$$k = 1$$

$$P = 20,492 \text{ KN/m}^2$$

Modulus Deck Beam pada geladak kimbul (poop deck) untuk a = 0,62 m

$$W = 0,75 \times 0,62 \times 20,492 \times (3,125)^2 \times 1,0 \quad (\text{cm}^3)$$

$$= 93,049 \text{ cm}^3$$

Profil yang direncanakan L 100 × 65 × 11

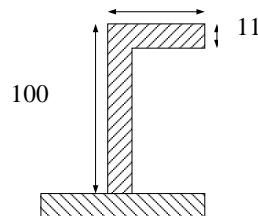

2) Modulus Deck Beam pada geladak sekoci (Boat Deck)

$$c = 0,75$$

a = jarak gading

$$= 0,62 \text{ m}$$

l = panjang tak ditumpu

$$= 3,125 \text{ m}$$

$$k = 1$$

PROFILE CONSTRUCTION

TUGAS AKHIR KM "BAHARI JAYA" GC 3805 BRT

$$P = 14,712 \text{ KN/m}^2$$

Modulus Deck Beam pada geladak sekoci (boat deck) untuk $a = 0,62 \text{ m}$

$$\begin{aligned} W &= 0,75 \times 0,62 \times 14,712 \times (3,125)^2 \times 1,0 \quad (\text{cm}^3) \\ &= 68,170 \text{ cm}^3 \end{aligned}$$

Profil yang direncanakan L 100 × 50 × 10

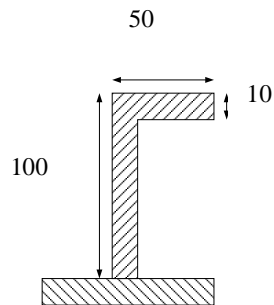

3) Modulus deck beam pada geladak kemudi (navigation deck) $a = 0,62 \text{ m}$

$$c = 0,75$$

$$a = 0,62 \text{ m}$$

l = panjang tak ditumpu

$$= 3,583 \text{ m}$$

$$k = 1$$

$$P = 13,136 \text{ KN/m}^2$$

$$\begin{aligned} W &= 0,75 \times 0,62 \times 13,136 \times (3,583)^2 \times 1,0 \quad (\text{cm}^3) \\ &= 78,414 \text{ cm}^3 \end{aligned}$$

Profil yang direncanakan L 100 × 75 × 9

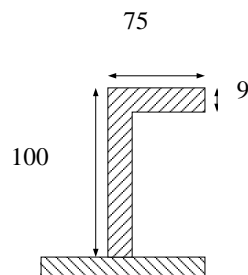

4) Modulus Deck Beam pada geladak kompas (compass deck)

$$c = 0,75$$

$$a = 0,62 \text{ m}$$

l = panjang tak ditumpu

$$= 3,083 \text{ m}$$

$$k = 1$$

$$P = 13,136 \text{ KN/m}^2$$

$$W = 0,75 \times 0,62 \times 13,136 \times (3,083)^2 \times 1,0 \quad (\text{cm}^3)$$

$$= 58,058 \text{ cm}^3$$

Profil yang direncanakan L 90 × 75 × 7

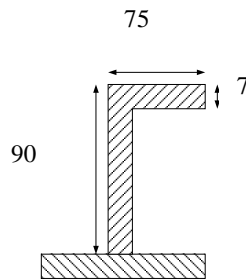

5) Modulus Deck Beam pada Fore castle deck

$$c = 0,75$$

$$a = 0,62 \text{ m}$$

l = panjang tak ditumpu

$$= 3,125 \text{ m}$$

$$k = 1$$

$$P = 33,04 \text{ KN/m}^2$$

Modulus Deck Beam pada geladak akil (fore castle deck) untuk a =

0,62 m

PROFILE CONSTRUCTION

TUGAS AKHIR KM "BAHARI JAYA" GC 3805 BRT

$$W = 0,75 \times 0,62 \times 33,04 \times (3,125)^2 \times 1,0 \quad (\text{cm}^3)$$
$$= 150,02 \text{ cm}^3$$

Profil yang direncanakan L 130 × 65 × 12

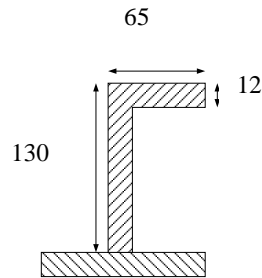

6) Modulus Deck Beam pada Winch deck

$$c = 0,75$$

$$a = 0,62 \text{ m}$$

l = panjang tak ditumpu

$$= 3,6 \text{ m}$$

$$k = 1$$

$$P = 18,629 \text{ KN/m}^2$$

$$W = 0,75 \times 0,62 \times 18,629 \times (3,6)^2 \times 1,0 \quad (\text{cm}^3)$$
$$= 112,265 \text{ cm}^3$$

Profil yang direncanakan L 130 × 65 × 10

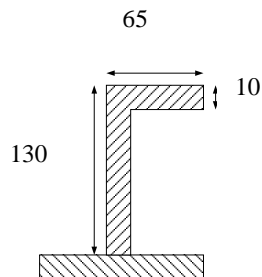

F.2. Balok Geladak Besar (Strong Beam)

a. Modulus penampang strong beam tidak boleh kurang dari :

PROFILE CONSTRUCTION

TUGAS AKHIR KM "BAHARI JAYA" GC 3805 BRT

$$W = c \times e \times l^2 \times P_D \times k \quad (\text{cm}^3)$$

Dimana,

$c = 0,75$ untuk Beam

$e =$ jarak gading besar

$$= 3 \times a$$

$$= 3 \times 0,62 = 1,86 \text{ m} \quad \text{Untuk } a = 0,62 \text{ m}$$

$l =$ panjang tak di tumpu

$$= 3,125 \text{ m}$$

$P_{D1} = 21,02 \text{ KN/m}^2$ untuk Buritan kapal

$P_{D2} = 19,11 \text{ KN/m}^2$ untuk Midship kapal

$P_{D3} = 26,43 \text{ KN/m}^2$ untuk Haluan kapal

$k = 1,0$

jadi :

1) Modulus Strong beam pada buritan kapal $a = 0,62 \text{ m}$

$$\begin{aligned} W &= 0,75 \times 1,86 \times (3,125)^2 \times 21,02 \times 1,0 \quad (\text{cm}^3) \\ &= 286,35 \text{ cm}^3 \end{aligned}$$

Profil yang direncanakan T 180 × 13 FP 70 × 13

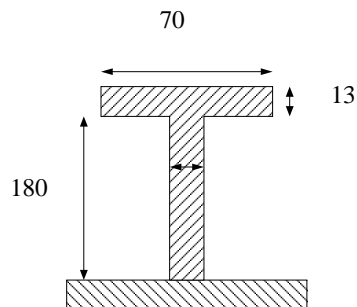

Koreksi modulus :

Lebar berguna $(40 - 50) = 50$

$$f = 7 \times 1,3 = 9,1 \text{ cm}^2$$

$$f_s = 18 \times 1,3 = 23,4 \text{ cm}^2$$

PROFILE CONSTRUCTION

TUGAS AKHIR KM "BAHARI JAYA" GC 3805 BRT

$$F = 50 \times 1,1 = 55 \text{ cm}^2$$

$$f/F = 0,17$$

$$f_s/F = 0,43$$

$$w = 0,29$$

$$\begin{aligned} W &= w \times F \times h \\ &= 0,29 \times 55 \times 18 \\ &= 287,1 \text{ cm}^3 \end{aligned}$$

W rencana > W perhitungan

$$287,1 > 286,35 \text{ (memenuhi)}$$

2) Modulus Strong beam pada buritan kapal a = 0,62 m

$$\begin{aligned} W &= 0,75 \times 1,86 \times (3,125)^2 \times 19,11 \times 1,0 \text{ (cm}^3\text{)} \\ &= 260,33 \text{ cm}^3 \end{aligned}$$

Profil yang direncanakan T 180 × 11 FP 80 × 11
80

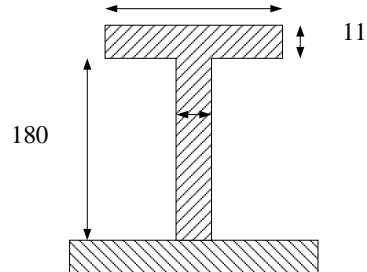

Koreksi modulus :

Lebar berguna (40 – 50) = 50

$$f = 8 \times 1,1 = 8,8 \text{ cm}^2$$

$$f_s = 18 \times 1,1 = 19,8 \text{ cm}^2$$

$$F = 50 \times 0,9 = 45 \text{ cm}^2$$

$$f/F = 0,2$$

$$f_s/F = 0,44$$

$$w = 0,33$$

$$W = w \times F \times h$$

PROFILE CONSTRUCTION

TUGAS AKHIR KM "BAHARI JAYA" GC 3805 BRT

$$= 0,33 \times 45 \times 18$$
$$= 267,3 \text{ cm}^3$$

W rencana > W perhitungan

$$297,3 > 260,33 \quad (\text{memenuhi})$$

3) Modulus Strong beam pada midship kapal a = 0,62 m

$$W = 0,75 \times 1,86 \times (3,125)^2 \times 26,43 \times 1,0 \text{ (cm}^3\text{)}$$
$$= 360,057 \text{ cm}^3$$

Profil yang direncanakan T 180 × 12 FP 80 × 12

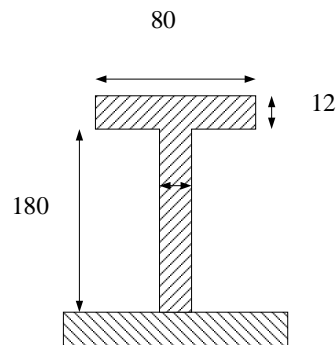

Koreksi modulus :

Lebar berguna (40 – 50) = 50

$$f = 8 \times 1,2 = 9,6 \text{ cm}^2$$

$$f_s = 18 \times 1,2 = 21,6 \text{ cm}^2$$

$$F = 50 \times 1,1 = 55 \text{ cm}^2$$

$$f/F = 0,17$$

$$f_s/F = 0,39$$

$$w = 0,27$$

$$W = w \times F \times h$$
$$= 0,27 \times 55 \times 18$$
$$= 367,3 \text{ cm}^3$$

W rencana > W perhitungan

$$367,3 > 360,057 \quad (\text{memenuhi})$$

1) Strong beam pada bangunan atas & rumah geladak

1) Pada Poop Deck

e = jarak gading besar

$$= 3 \times a$$

$$= 3 \times 0,62 = 1,86 \text{ m Untuk } a = 0,62 \text{ m}$$

l = panjang tak di tumpu

$$= 3,125 \text{ m}$$

$$P_D = 16,393 \text{ KN/m}^2$$

Modulus Strong Beam pada geladak kembang (poop deck) untuk a = 0,62 m

$$W = 0,75 \times 1,86 \times (3,125)^2 \times 16,393 \times 1,0 \text{ (cm}^3\text{)}$$
$$= 223,32 \text{ cm}^3$$

Profil yang direncanakan T 180 × 10 FP 70 × 10

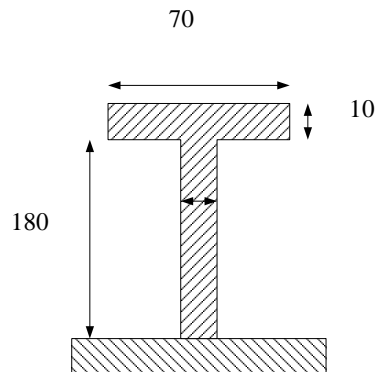

Koreksi modulus

Lebar berguna (40 – 50) = 50

$$f = 7 \times 1 = 7 \text{ cm}^2$$

$$f_s = 18 \times 1 = 18 \text{ cm}^2$$

$$F = 50 \times 0,9 = 45 \text{ cm}^2$$

PROFILE CONSTRUCTION

TUGAS AKHIR KM "BAHARI JAYA" GC 3805 BRT

$$f/F = 0,16$$

$$f_s/F = 0,40$$

$$w = 0,28$$

$$W = w \times F \times h$$

$$= 0,28 \times 45 \times 18$$

$$= 226,8 \text{ cm}^3$$

W rencana > W perhitungan

$$226,8 > 223,32 \quad (\text{memenuhi})$$

2) Pada Boat Deck

e = jarak gading besar

$$= 3 \times a$$

$$= 3 \times 0,62 = 1,86 \text{ m} \quad \text{Untuk } a = 0,62 \text{ m}$$

l = panjang tak di tumpu

$$= 3,125 \text{ m}$$

$$P_D = 11,77 \text{ KN/m}^2$$

Modulus Strong Beam pada geladak sekoci (boat deck) untuk a = 0,62 m

$$W = 0,75 \times 1,86 \times (3,125)^2 \times 11,77 \times 1,0 \text{ (cm}^3\text{)}$$
$$= 160,34 \text{ cm}^3$$

Profil yang direncanakan T 170 × 8 FP 70 × 8

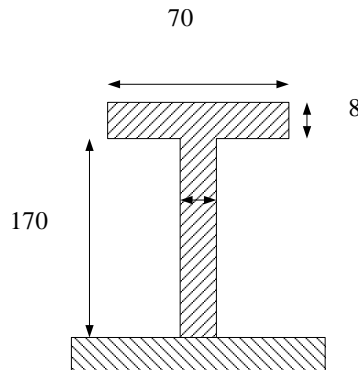

Koreksi modulus :

PROFILE CONSTRUCTION

TUGAS AKHIR KM "BAHARI JAYA" GC 3805 BRT

Lebar berguna $(40 - 50) = 50$

$$f = 7 \times 0,8 = 5,6 \text{ cm}^2$$

$$f_s = 17 \times 0,8 = 13,6 \text{ cm}^2$$

$$F = 50 \times 0,8 = 40 \text{ cm}^2$$

$$f/F = 0,14$$

$$f_s/F = 0,34$$

$$w = 0,24$$

$$\begin{aligned} W &= w \times F \times h \\ &= 0,24 \times 40 \times 17 \\ &= 163,2 \text{ cm}^3 \end{aligned}$$

W rencana > W perhitungan

$$163,2 > 160,34 \text{ (memenuhi)}$$

3) Pada Navigation Deck

$$P_d = 10,509 \text{ KN/m}^2$$

e = jarak gading besar

$$= 3x a$$

$$= 3 \times 0,62 = 1,86 \text{ m} \quad \text{Untuk } a = 0,62 \text{ m}$$

l = panjang tak di tumpu

$$= 3,583 \text{ m}$$

$$\begin{aligned} W &= 0,75 \times 1,86 \times (3,586)^2 \times 10,509 \times 1,0 \text{ (cm}^3\text{)} \\ &= 188,202 \text{ cm}^3 \end{aligned}$$

Profil yang direncanakan T 170 × 9 FP 70 × 9

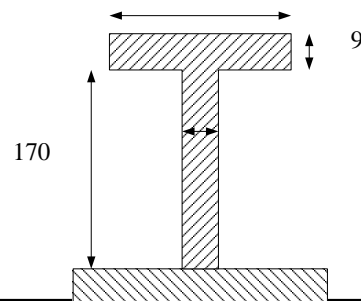

PROFILE CONSTRUCTION

TUGAS AKHIR KM "BAHARI JAYA" GC 3805 BRT

Koreksi modulus :

Lebar berguna $(40 - 50) = 50$

$$f = 7 \times 0,9 = 6,3 \text{ cm}^2$$

$$f_s = 17 \times 0,9 = 15,3 \text{ cm}^2$$

$$F = 50 \times 0,7 = 35 \text{ cm}^2$$

$$f/F = 0,18$$

$$f_s/F = 0,44$$

$$w = 0,32$$

$$W = w \times F \times h$$

$$= 0,32 \times 35 \times 17$$

$$= 190,4 \text{ cm}^3$$

W rencana > W perhitungan

$$190,4 > 188,202 \quad (\text{memenuhi})$$

4) Pada Compass Deck

$$P_d = 10,509 \text{ KN/m}^2$$

e = jarak gading besar

$$= 3x a$$

$$= 3 \times 0,62 = 1,86 \text{ m} \quad \text{Untuk } a = 0,62 \text{ m}$$

l = panjang tak di tumpu

$$= 3,083 \text{ m}$$

$$W = 0,75 \times 1,86 \times (3,083)^2 \times 10,509 \times 1,0 \text{ (cm}^3\text{)}$$

$$= 137,343 \text{ cm}^3$$

PROFILE CONSTRUCTION

TUGAS AKHIR KM "BAHARI JAYA" GC 3805 BRT

Profil yang direncanakan T 160 × 8 FP 70 × 8

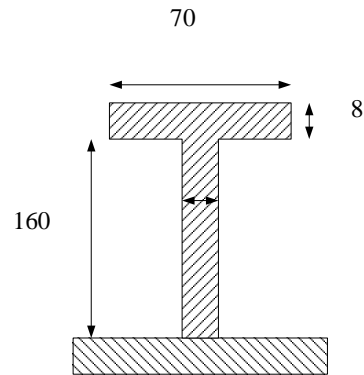

Koreksi modulus :

Lebar berguna $(40 - 50) = 50$

$$f = 7 \times 0,8 = 5,6 \text{ cm}^2$$

$$f_s = 16 \times 0,8 = 12,8 \text{ cm}^2$$

$$F = 50 \times 0,6 = 30 \text{ cm}^2$$

$$f/F = 0,19$$

$$f_s/F = 0,43$$

$$w = 0,31$$

$$\begin{aligned} W &= w \times F \times h \\ &= 0,31 \times 30 \times 16 \\ &= 148,8 \text{ cm}^3 \end{aligned}$$

W rencana > W perhitungan

$$148,8 > 139,43 \quad (\text{memenuhi})$$

5) Fore castle Deck

e = jarak gading besar

$$= 3x a$$

$$= 3 \times 0,62 = 1,86 \text{ m} \quad \text{Untuk } a = 0,62 \text{ m}$$

l = panjang tak di tumpu

$$= 3,125 \text{ m}$$

$$P_d = 26,43 \text{ KN/m}^2$$

PROFILE CONSTRUCTION

TUGAS AKHIR KM "BAHARI JAYA" GC 3805 BRT

Modulus Strong Beam pada geladak akil (fore castle deck) untuk a
= 0,62 m

$$\begin{aligned}W &= 0,75 \times 1,86 \times (3,125)^2 \times 26,43 \times 1,0 \text{ (cm}^3\text{)} \\ &= 360,057 \text{ cm}^3\end{aligned}$$

Profil yang direncanakan T 220×12 FP 80 × 12

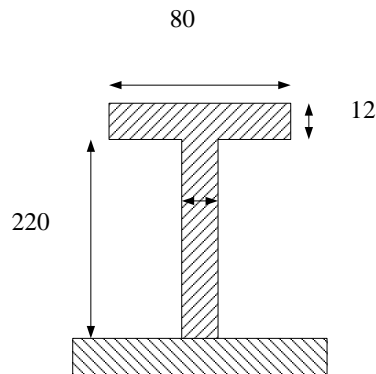

Koreksi modulus :

Lebar berguna (40 – 50) = 50

$$f = 8 \times 1,2 = 9,6 \text{ cm}^2$$

$$f_s = 22 \times 1,2 = 26,4 \text{ cm}^2$$

$$F = 50 \times 0,9 = 45 \text{ cm}^2$$

$$f/F = 0,21$$

$$f_s/F = 0,59$$

$$w = 0,37$$

$$\begin{aligned}W &= w \times F \times h \\ &= 0,37 \times 45 \times 22 \\ &= 366,3 \text{ cm}^3\end{aligned}$$

W rencana > W perhitungan

$$366,3 > 360,057 \quad (\text{memenuhi})$$

6) Strong beam pada Winch Deck

$$P_s = 14,903 \text{ KN/m}^2$$

e = jarak gading besar

$$= 3 \times a$$

PROFILE CONSTRUCTION

TUGAS AKHIR KM “BAHARI JAYA” GC 3805 BRT

$$= 3 \times 0,62 = 1,86 \text{ m} \quad \text{Untuk } a = 0,62 \text{ m}$$

l = panjang tak di tumpu

$$= 3,6 \text{ m}$$

$$W = 0,75 \times 1,86 \times (3,6)^2 \times 14,903 \times 1,0 \text{ (cm}^3\text{)}$$

$$= 269,43 \text{ cm}^3$$

Profil yang direncanakan T 210 × 9 FP 90 × 9
90

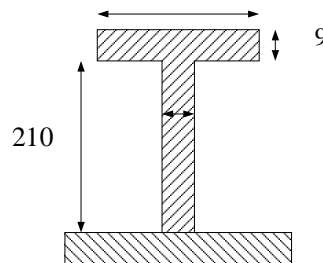

Koreksi modulus :

Lebar berguna (40 – 50) = 50

$$f = 9 \times 0,9 = 8,1 \text{ cm}^2$$

$$f_s = 21 \times 0,9 = 18,9 \text{ cm}^2$$

$$F = 50 \times 0,8 = 40 \text{ cm}^2$$

$$f/F = 0,20$$

$$f_s/F = 0,47$$

$$w = 0,33$$

$$W = w \times F \times h$$

$$= 0,33 \times 40 \times 21$$

$$= 277,2 \text{ cm}^3$$

W rencana > W perhitungan

$$277,2 > 269,43 \quad \text{(memenuhi)}$$

PROFILE CONSTRUCTION

TUGAS AKHIR KM "BAHARI JAYA" GC 3805 BRT

G. PENUMPU GELADAK (DECK GIRDER)

Tinggi penumpu tidak boleh kurang dari $1/25$ panjang tak ditumpu tinggi plat bilah hadap, penumpu yang dilubangi (lubang las) untuk balok geladak yang menerus minimal $1,5 \times$ tinggi geladak.

G.1. Modulus Penumpu tengah (Center Deck Girder)

$$W = c \times e \times l^2 \times P_d \times k \quad (\text{cm}^3)$$

Dimana :

$$c = 0,75$$

$$e = \text{lebar pembebanan} \\ = 3,125 \text{ m}$$

$$l = \text{panjang tak di tumpu} \\ = 3 \times a$$

$$= 3 \times 0,62 = 2,4 \quad \text{m} \quad a = 0,62 \text{ m}$$

$$P_{D1} = 21,02 \quad \text{KN/m}^2 \quad (\text{buritan})$$

$$P_{D1} = 19,11 \quad \text{KN/m}^2 \quad (\text{midship})$$

$$P_{D1} = 26,43 \quad \text{KN/m}^2 \quad (\text{haluan})$$

$$k = 1,0$$

- a. Modulus penampang CDG pada daerah $0,1 L$ dari AP tidak boleh kurang dari :

$$W = 0,75 \times 3,125 \times (1,86)^2 \times 21,02 \times 1,0 \quad (\text{cm}^3) \\ = 170,439 \text{ cm}^3$$

Profil yang direncanakan T 150 \times 12 FP 60 \times 12

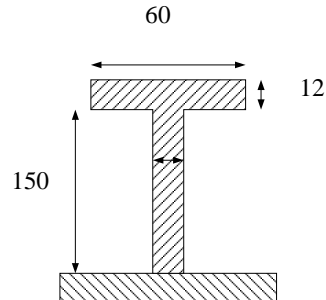

Koreksi modulus :

$$\text{Lebar berguna } (40 - 50) = 50$$

$$f = 6 \times 1,2 = 7,2 \quad \text{cm}^2$$

PROFILE CONSTRUCTION

TUGAS AKHIR KM "BAHARI JAYA" GC 3805 BRT

$$\begin{aligned}f_s &= 15 \times 1,2 = 18 \text{ cm}^2 \\F &= 50 \times 1,1 = 55 \text{ cm}^2 \\f/F &= 0,13 \\f_s/F &= 0,33 \\w &= 0,21\end{aligned}$$

$$\begin{aligned}W &= w \times F \times h \\&= 0,21 \times 55 \times 15 \\&= 173,25 \text{ cm}^3\end{aligned}$$

W rencana > W perhitungan

$$173,25 > 170,439 \quad (\text{memenuhi})$$

- b. Modulus penampang penumpu tengah (Centre Deck Girder) pada daerah 0,6 L, tengah kapal tidak boleh kurang dari :

$$\begin{aligned}W &= 0,75 \times 3,125 \times (1,86)^2 \times 19,11 \times 1,0 \text{ (cm}^3\text{)} \\&= 154,952 \text{ cm}^3\end{aligned}$$

Profil yang direncanakan T 150 × 9 FP 70 × 9

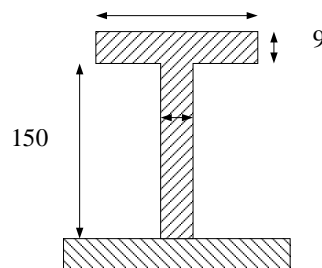

Koreksi modulus :

Lebar berguna (40 – 50) = 50

$$\begin{aligned}f &= 7 \times 0,9 = 6,3 \text{ cm}^2 \\f_s &= 15 \times 0,9 = 13,5 \text{ cm}^2 \\F &= 50 \times 0,9 = 45 \text{ cm}^2 \\f/F &= 0,14 \\f_s/F &= 0,3 \\w &= 0,23\end{aligned}$$

PROFILE CONSTRUCTION

TUGAS AKHIR KM "BAHARI JAYA" GC 3805 BRT

$$\begin{aligned}W &= w \times F \times h \\ &= 0,23 \times 45 \times 15 \\ &= 155,25 \text{ cm}^3\end{aligned}$$

W rencana > W perhitungan

$$155,25 > 154,952 \quad (\text{memenuhi})$$

- c. Modulus penampang penumpu tengah (Center Deck Girder) pada 0,1 L dari FP tidak boleh kurang dari :

$$\begin{aligned}W &= 0,75 \times 3,125 \times (1,86)^2 \times 26,43 \times 1,0 \text{ (cm}^3\text{)} \\ &= 214,30 \text{ cm}^3\end{aligned}$$

Profil yang direncanakan T 180 × 11 FP 60 × 11

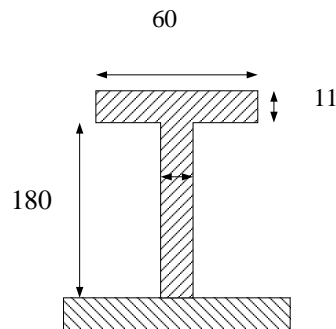

Koreksi modulus :

Lebar berguna (40 – 50) = 50

$$f = 6 \times 1,1 = 6,6 \text{ cm}^2$$

$$f_s = 18 \times 1,1 = 19,8 \text{ cm}^2$$

$$F = 50 \times 1,1 = 55 \text{ cm}^2$$

$$f/F = 0,12$$

$$f_s/F = 0,36$$

$$w = 0,22$$

$$\begin{aligned}W &= w \times F \times h \\ &= 0,22 \times 55 \times 18 \\ &= 217,8 \text{ cm}^3\end{aligned}$$

W rencana > W perhitungan

$$217,8 > 214,3 \quad (\text{memenuhi})$$

PROFILE CONSTRUCTION

TUGAS AKHIR KM "BAHARI JAYA" GC 3805 BRT

➤ Center Deck Girder (CDG) Pada Bangunan Atas

a. Poop Deck

Untuk $a = 0,62 \text{ m}$:

$$\begin{aligned} W &= 0,75 \times 3,125 \times (1,86)^2 \times 16,393 \times 1,0 \text{ (cm}^3\text{)} \\ &= 132,91 \text{ cm}^3 \end{aligned}$$

Profil yang direncanakan T 150 × 9 FP 60 × 9

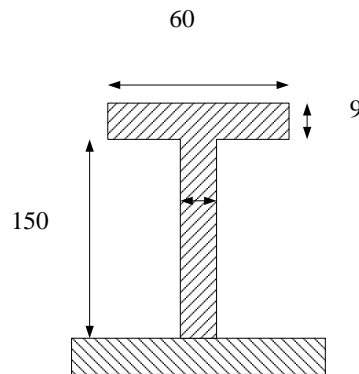

Koreksi modulus

Lebar berguna $(40 - 50) = 50$

$$f = 6 \times 0,9 = 5,4 \text{ cm}^2$$

$$f_s = 15 \times 0,9 = 13,5 \text{ cm}^2$$

$$F = 50 \times 0,9 = 45 \text{ cm}^2$$

$$f/F = 0,12$$

$$f_s/F = 0,3$$

$$w = 0,21$$

$$\begin{aligned} W &= w \times F \times h \\ &= 0,21 \times 45 \times 15 \\ &= 141,75 \text{ cm}^3 \end{aligned}$$

$W \text{ rencana} > W \text{ perhitungan}$

$$141,75 > 132,91 \quad (\text{memenuhi})$$

b. Boat Deck

Untuk $a = 0,62 \text{ m}$

PROFILE CONSTRUCTION

TUGAS AKHIR KM "BAHARI JAYA" GC 3805 BRT

$$\begin{aligned}W &= 0,75 \times 3,125 \times (1,86)^2 \times 11,77 \times 1,0 \text{ (cm}^3\text{)} \\ &= 96,48 \text{ cm}^3\end{aligned}$$

Profil yang direncanakan T 140 × 8 FP 60 × 8
80

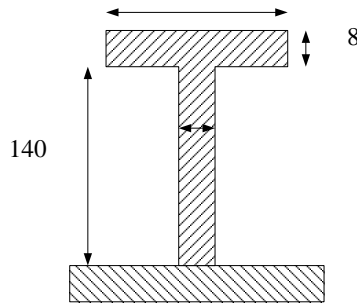

Koreksi modulus :

Lebar berguna (40 – 50) = 50

$$f = 5 \times 0,8 = 4 \text{ cm}^2$$

$$f_s = 14 \times 0,8 = 11,2 \text{ cm}^2$$

$$F = 50 \times 0,8 = 40 \text{ cm}^2$$

$$f/F = 0,1$$

$$f_s/F = 0,28$$

$$w = 0,20$$

$$W = w \times F \times h$$

$$= 0,20 \times 40 \times 14$$

$$= 112 \text{ cm}^3$$

W rencana > W perhitungan

112 > 96,48 (memenuhi)

c. Navigation Deck

$$\begin{aligned}W &= 0,75 \times 3,583 \times (1,86)^2 \times 10,509 \times 1,0 \text{ (cm}^3\text{)} \\ &= 97,698 \text{ cm}^3\end{aligned}$$

Profil yang direncanakan T 130 × 8 FP 60 × 8

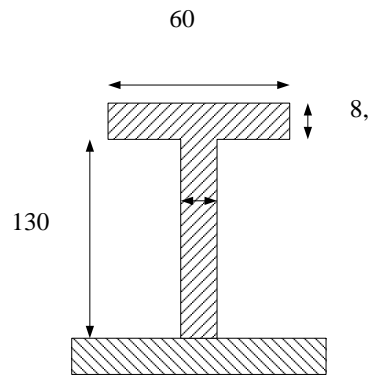

Koreksi modulus :

Lebar berguna (40 – 50) = 50

$$f = 6 \times 0,8 = 4,8 \text{ cm}^2$$

$$f_s = 13 \times 0,8 = 10,4 \text{ cm}^2$$

$$F = 50 \times 0,7 = 35 \text{ cm}^2$$

$$f/F = 0,14$$

$$f_s/F = 0,3$$

$$w = 0,22$$

$$\begin{aligned} W &= w \times F \times h \\ &= 0,22 \times 35 \times 13 \\ &= 100,1 \text{ cm}^3 \end{aligned}$$

W rencana > W perhitungan

$$100,1 > 97,698 \text{ (memenuhi)}$$

d. Compas Deck

$$\begin{aligned} W &= 0,75 \times 3,086 \times (1,86)^2 \times 10,509 \times 1,0 \text{ (cm}^3\text{)} \\ &= 84,065 \text{ cm}^3 \end{aligned}$$

Profil yang direncanakan T 160 × 6 FP 50 × 6 50

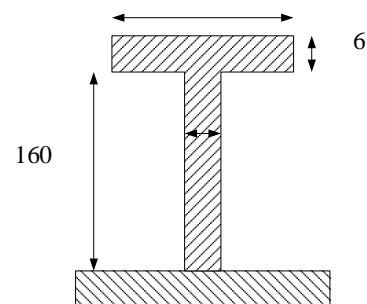

PROFILE CONSTRUCTION

TUGAS AKHIR KM "BAHARI JAYA" GC 3805 BRT

Koreksi modulus :

Lebar berguna $(40 - 50) = 50$

$$f = 5 \times 0,6 = 3 \text{ cm}^2$$

$$f_s = 16 \times 0,6 = 9,6 \text{ cm}^2$$

$$F = 50 \times 0,6 = 30 \text{ cm}^2$$

$$f/F = 0,1$$

$$f_s/F = 0,32$$

$$w = 0,18$$

$$W = w \times F \times h$$

$$= 0,18 \times 30 \times 16$$

$$= 86,40 \text{ cm}^3$$

W rencana > W perhitungan

86,40 > 84,065 (memenuhi)

e. Forecastle Deck

Untuk $a = 0,62$

$$W = 0,75 \times 3,125 \times (1,86)^2 \times 26,43 \times 1,0 \text{ (cm}^3\text{)}$$

$$= 214,306 \text{ cm}^3$$

Profil yang direncanakan T 180 × 9 FP 60 × 9

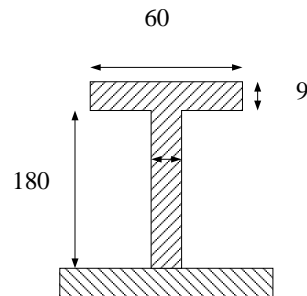

Koreksi modulus :

Lebar berguna $(40 - 50) = 50$

$$f = 6 \times 0,9 = 5,4 \text{ cm}^2$$

$$f_s = 18 \times 0,9 = 16,2 \text{ cm}^2$$

$$F = 50 \times 0,9 = 45 \text{ cm}^2$$

$$f/F = 0,12$$

$$f_s/F = 0,36$$

PROFILE CONSTRUCTION

TUGAS AKHIR KM "BAHARI JAYA" GC 3805 BRT

$$w = 0,27$$

$$\begin{aligned} W &= w \times F \times h \\ &= 0,27 \times 45 \times 18 \\ &= 218,7 \text{ cm}^3 \end{aligned}$$

W rencana > W perhitungan

$$218,7 > 214,306 \quad (\text{memenuhi})$$

f. Winch Deck

$$\begin{aligned} W &= 0,75 \times 3,6 \times (1,86)^2 \times 14,903 \times 1,0 \text{ (cm}^3\text{)} \\ &= 139,207 \text{ cm}^3 \end{aligned}$$

Profil yang direncanakan T 150×9 FP 60×9

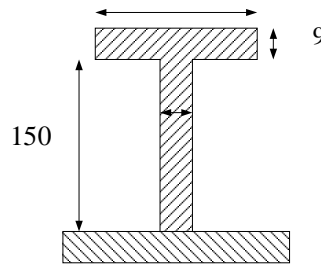

Koreksi modulus :

Lebar berguna (40 – 50) = 50

$$f = 6 \times 0,9 = 5,4 \text{ cm}^2$$

$$f_s = 15 \times 0,9 = 13,5 \text{ cm}^2$$

$$F = 50 \times 0,8 = 40 \text{ cm}^2$$

$$f/F = 0,135$$

$$f_s/F = 0,33$$

$$w = 0,24$$

$$\begin{aligned} W &= w \times F \times h \\ &= 0,24 \times 40 \times 15 \\ &= 144 \text{ cm}^3 \end{aligned}$$

PROFILE CONSTRUCTION

TUGAS AKHIR KM "BAHARI JAYA" GC 3805 BRT

W rencana > W perhitungan

$$144 > 139,207 \quad (\text{memenuhi})$$

G.2. Modulus Penumpu samping (Side Deck Girder)

$$W = c \times e \times l^2 \times Pd \times k \quad (\text{cm}^3)$$

Dimana :

$$c = 0,75$$

e = lebar pembebanan

$$= 3,125 \text{ m}$$

l = panjang tak di tumpu

$$= 3 \times a$$

$$= 3 \times 0,62 = 2,4 \quad \text{m} \quad a = 0,62 \text{ m}$$

$$P_{D1} = 21,02 \quad \text{KN/m}^2 \quad (\text{buritan})$$

$$P_{D1} = 19,11 \quad \text{KN/m}^2 \quad (\text{midship})$$

$$P_{D1} = 26,43 \quad \text{KN/m}^2 \quad (\text{haluan})$$

$$k = 1,0$$

- a. Modulus penampang SDG pada daerah 0,1 L dari AP tidak boleh kurang dari :

$$\begin{aligned} W &= 0,75 \times 3,125 \times (1,86)^2 \times 21,02 \times 1,0 \quad (\text{cm}^3) \\ &= 170,439 \text{ cm}^3 \end{aligned}$$

Profil yang direncanakan T 150 × 12 FP 60 × 12

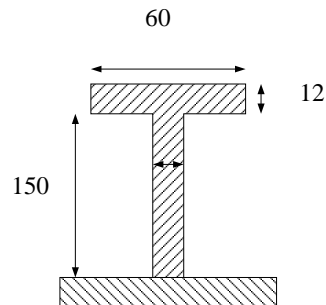

Koreksi modulus :

Lebar berguna (40 – 50) = 50

$$f = 6 \times 1,2 = 7,2 \quad \text{cm}^2$$

$$f_s = 15 \times 1,2 = 18 \quad \text{cm}^2$$

PROFILE CONSTRUCTION

TUGAS AKHIR KM "BAHARI JAYA" GC 3805 BRT

$$\begin{aligned}F &= 50 \times 1,1 = 55 \text{ cm}^2 \\f/F &= 0,13 \\f_s/F &= 0,33 \\w &= 0,21\end{aligned}$$

$$\begin{aligned}W &= w \times F \times h \\&= 0,21 \times 55 \times 15 \\&= 173,25 \text{ cm}^3\end{aligned}$$

W rencana > W perhitungan

$$173,25 > 170,439 \quad (\text{memenuhi})$$

- b. Modulus penampang SDG pada daerah 0,6 L, tengah kapal tidak boleh kurang dari :

$$\begin{aligned}W &= 0,75 \times 3,125 \times (1,86)^2 \times 19,11 \times 1,0 \text{ (cm}^3\text{)} \\&= 154,952 \text{ cm}^3\end{aligned}$$

Profil yang direncanakan T 150 × 9 FP 70 × 9

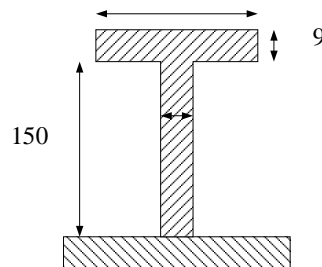

Koreksi modulus :

Lebar berguna (40 – 50) = 50

$$\begin{aligned}f &= 7 \times 0,9 = 6,3 \text{ cm}^2 \\f_s &= 15 \times 0,9 = 13,5 \text{ cm}^2 \\F &= 50 \times 0,9 = 45 \text{ cm}^2 \\f/F &= 0,14 \\f_s/F &= 0,3 \\w &= 0,23 \\W &= w \times F \times h\end{aligned}$$

PROFILE CONSTRUCTION

TUGAS AKHIR KM "BAHARI JAYA" GC 3805 BRT

$$\begin{aligned} &= 0,23 \times 45 \times 15 \\ &= 155,25 \text{ cm}^3 \end{aligned}$$

W rencana > W perhitungan

$$155,25 > 154,952 \quad (\text{memenuhi})$$

c. Modulus penampang SDG pada 0,1 L dari FP tidak boleh kurang dari :

$$\begin{aligned} W &= 0,75 \times 3,125 \times (1,86)^2 \times 26,43 \times 1,0 \text{ (cm}^3\text{)} \\ &= 214,30 \text{ cm}^3 \end{aligned}$$

Profil yang direncanakan T 180 × 11 FP 60 × 11

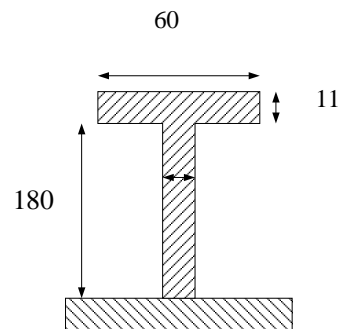

Koreksi modulus :

Lebar berguna (40 – 50) = 50

$$f = 6 \times 1,1 = 6,6 \text{ cm}^2$$

$$f_s = 18 \times 1,1 = 19,8 \text{ cm}^2$$

$$F = 50 \times 1,1 = 55 \text{ cm}^2$$

$$f/F = 0,12$$

$$f_s/F = 0,36$$

$$w = 0,22$$

$$\begin{aligned} W &= w \times F \times h \\ &= 0,22 \times 55 \times 18 \\ &= 217,8 \text{ cm}^3 \end{aligned}$$

W rencana > W perhitungan

$$217,8 > 214,3 \quad (\text{memenuhi})$$

d. Modulus penampang penumpu samping pada Ambang Palka tidak boleh kurang dari :

$$W = c \times e \times I^2 \times Pd \times k \quad (\text{cm}^3)$$

PROFILE CONSTRUCTION

TUGAS AKHIR KM "BAHARI JAYA" GC 3805 BRT

Dimana :

$$c = 0,75$$

e = lebar pembebanan

$$= (0,5 \times 1,915) + 6,25 \text{ m}$$

$$= 0,9575 + 6,25$$

$$= 7,2075 \text{ m}$$

l = panjang tak di tumpu

$$= 3 \times 0,62 = 1,86 \text{ m}$$

$$P_{D1} = 23,88 \text{ kN/m}^2 \quad (\text{untuk daerah ruang muat tengah})$$

- untuk daerah ruang muat tengah

$$W = 0,75 \times 7,2075 \times (1,86)^2 \times 23,88 \times 1,0 \text{ (cm}^3\text{)}$$

$$= 446,586 \text{ cm}^3$$

$$\text{Profil} = \text{L } 250 \times 90 \times 12$$

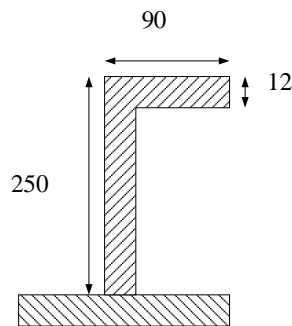

H. BULKHEAD (SEKAT KEDAP)

Sebuah kapal harus mempunyai sekat tubrukan pada haluan sekat buritan, sekat ruang mesin dan sekat antar ruang muat.

H.1. Sekat Tubrukan pada haluan

Tebal sekat kedap air :

$$t_s = C_p \times a \times \sqrt{P} + t_k \quad (\text{mm})$$

Dimana:

$$C_p = 1,1 \sqrt{f}, \quad \longrightarrow \quad f = \frac{235}{\text{Re.H}}, \quad \text{Re H} = 265 \text{ N/mm}^2$$

PROFILE CONSTRUCTION

TUGAS AKHIR KM "BAHARI JAYA" GC 3805 BRT

$$= 1,1 \sqrt{0,917} = \frac{235}{265}$$

$$= 1,035 = 0,886 \text{ N/mm}^2$$

$$a = 0,6 \text{ (stiffeners spacing)}$$

$$P = 9,81 \times h$$

Dimana,

$$h = \left(\frac{H - h_{DB}}{2} \right) + 1 \text{ m}$$

$$= 4,855 \text{ m}$$

$$P = 9,81 \times h$$

$$= 9,81 \times 4,855 = 47,628 \text{ kN/m}^2$$

$$t_k = 1,5$$

$$t_{\min} = 6,0 \times \sqrt{f}$$

$$= 6,0 \times \sqrt{0,886}$$

$$= 6,0 \times 0,941$$

$$= 5,647 \text{ mm}$$

jadi,

$$t_{s1} = 1,035 \times 0,6 \times \sqrt{49,540} + 1,5$$

$$= 5,870 \text{ mm} > t_{\min}$$

❖ karena tebal yang direncanakan lebih tebal dari t_{\min} , maka diambil t_{s1}

$$= 8 \text{ mm}$$

H.2. Tebal sekat kedap lainnya

$$t_s = C_p \times a \times \sqrt{P} + t_k \quad (\text{mm})$$

Dimana:

$$C_p = 0,9 \sqrt{f}, \longrightarrow f = \frac{235}{\text{Re} \cdot H} \cdot \text{Re} \cdot H = 265 \text{ N/mm}^2$$

$$= 0,9 \sqrt{0,886} = \frac{235}{265}$$

$$= 0,892 = 0,886 \text{ N/mm}^2$$

$$a = 0,6 \text{ (stiffeners spacing)}$$

$$P = 9,81 \times h$$

Dimana,

$$h = \left(\frac{H - h_{DB}}{2} \right) + 1 \text{ m}$$

$$= 4,855 \text{ m}$$

$$P = 9,81 \times h$$

$$= 9,81 \times 4,855 = 47,628 \text{ kN/m}^2$$

$$t_k = 1,5$$

$$t_{\min} = 6,0 \times \sqrt{f}$$

$$= 6,0 \times \sqrt{0,886}$$

$$= 6,0 \times 0,941$$

$$= 5,647 \text{ mm}$$

jadi,

$$t_{s1} = 0,892 \times 0,625 \times \sqrt{47,628} + 1,5$$

$$= 5,348 \text{ mm} < t_{\min} \approx \text{diambil } 5,647 \text{ mm}$$

- ❖ karena tebalplat yang direncanakan lebih kecil dari tebal plat min, maka diambil tebal

$$t_{s1} = t_{\min} + 1 = 5,647 + 1 = 6,647 \text{ mm} \approx 7 \text{ mm}$$

H.3. Modulus Penampang Penegar Sekat Kedap Air

$$W = C_s \times a \times I^2 \times P \quad (\text{cm}^3)$$

Dimana :

$$C_s = 0,33 \times f$$

$$= 0,33 \times 0,886$$

$$= 0,292$$

$$I = \left(\frac{H - h_{DB}}{3} \right)$$

$$= 2,57 \text{ m}$$

$$P = 47,628 \text{ kN/m}^2$$

$$a = 0,625 \text{ m}$$

maka :

$$W = 0,292 \times 0,625 \times (2,57)^2 \times 47,628$$

PROFILE CONSTRUCTION

TUGAS AKHIR KM "BAHARI JAYA" GC 3805 BRT

$$= 57,410 \text{ cm}^3$$

Profil yang di rencanakan L $90 \times 75 \times 7$
75

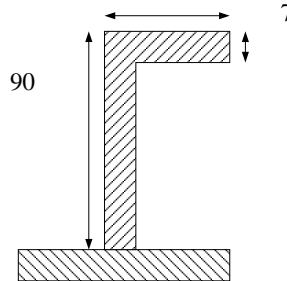

H.4. Stiffener pada sekat antara ruang muat

Modulus penampang stiffener antara ruang muat tidak boleh kurang dari :

$$W = C_s \times a \times I^2 \times P \quad (\text{cm}^3)$$

Dimana :

$$\begin{aligned} C_s &= 0,265 \times f \\ &= 0,265 \times 0,886 \\ &= 0,234 \end{aligned}$$

$$\begin{aligned} I &= \left(\frac{H - h_{DB}}{3} \right) \\ &= 2,57 \text{ m} \end{aligned}$$

$$P = 47,628 \text{ kN/m}^2$$

$$a = 0,625 \text{ m}$$

maka :

$$\begin{aligned} W &= 0,234 \times 0,625 \times (2,57)^2 \times 47,628 \\ &= 52,102 \text{ cm}^3 \end{aligned}$$

Profil yang di rencanakan L $90 \times 60 \times 8$
60

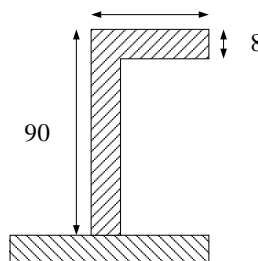

H.5. Stiffener pada sekat antara ruang muat dengan kamar mesin

Modulus penampang stiffener antara ruang muat dengan kamar mesin tidak boleh kurang dari :

$$W = C_s \times a \times I^2 \times P \quad (\text{cm}^3)$$

Dimana :

$$\begin{aligned} C_s &= 0,265 \times f \\ &= 0,265 \times 0,886 \\ &= 0,234 \end{aligned}$$

$$\begin{aligned} I &= \left(\frac{H - h_{DBKM}}{3} \right) \\ &= 2,497 \text{ m} \end{aligned}$$

$$P = 9,81 \times h$$

Dimana,

$$\begin{aligned} h &= \left(\frac{H - h_{DBKM}}{2} \right) + 1 \\ &= 4,745 \text{ m} \end{aligned}$$

$$\begin{aligned} P &= 9,81 \times h \\ &= 9,81 \times 4,745 = 46,548 \text{ kN/m}^2 \end{aligned}$$

$$a = 0,625 \text{ m}$$

maka :

$$\begin{aligned} W &= 0,234 \times 0,625 \times (2,497)^2 \times 46,548 \\ &= 42,446 \text{ cm}^3 \end{aligned}$$

Profil yang di rencanakan I 90 × 60 × 6

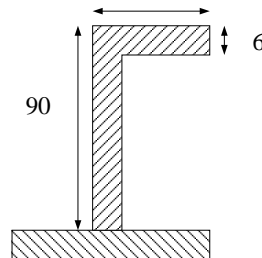

Stifner pada bangunan atas (sec. 16.c.3.1)

$$W = 0,35 \times a \times I^2 \times P \times 1,0 \quad \text{cm}^3$$

a. Penegar (stiffener) untuk Poop Deck

PROFILE CONSTRUCTION

TUGAS AKHIR KM "BAHARI JAYA" GC 3805 BRT

$$\begin{aligned} W &= 0,35 \times 0,625 \times (2,2)^2 \times 46,656 \times 1 \\ &= 11,967 \text{ cm}^3 \end{aligned}$$

Profil yang di rencanakan L = 80 × 65 × 8

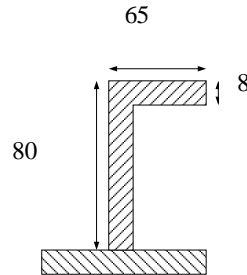

b. Penegar (stiffener) untuk Boat Deck

$$\begin{aligned} W &= 0,35 \times 0,625 \times (2,2)^2 \times 42,953 \times 1 \\ &= 45,476 \text{ cm}^3 \end{aligned}$$

Profil yang di rencanakan L 75 × 55 × 9

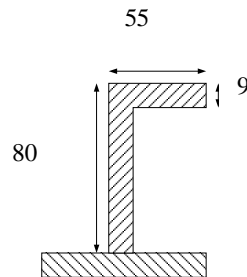

c. Penegar (stiffener) untuk Navigation Deck

$$\begin{aligned} W &= 0,35 \times 0,625 \times (2,2)^2 \times 39,797 \times 1 \\ &= 42,133 \text{ cm}^3 \end{aligned}$$

Profil yang di rencanakan L 90 × 60 × 6

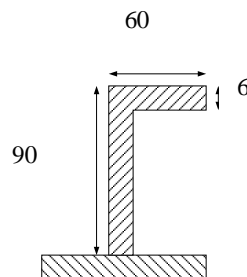

d. Penegar (stiffener) untuk Compass Deck

$$W = 0,35 \times 0,625 \times (2,2)^2 \times 37,069 \times 1$$

PROFILE CONSTRUCTION

TUGAS AKHIR KM "BAHARI JAYA" GC 3805 BRT

$$= 39,247 \text{ cm}^3$$

Profil yang di rencanakan L 90 × 60 × 6

60

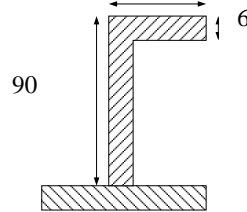

e. Penegar (stiffener) untuk winch Deck

$$\begin{aligned} W &= 0,35 \times 0,625 \times (2,2)^2 \times 17,237 \times 1 \\ &= 18,250 \text{ cm}^3 \end{aligned}$$

Profil yang di rencanakan L 60 × 40 × 6

40

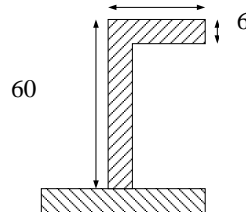

f. Penegar (stiffener) untuk Fore Castle Deck

$$\begin{aligned} W &= 0,35 \times 0,625 \times (2,2)^2 \times 68,734 \times 1 \\ &= 72,772 \text{ cm}^3 \end{aligned}$$

Profil yang di rencanakan L 100 × 50 × 10

50

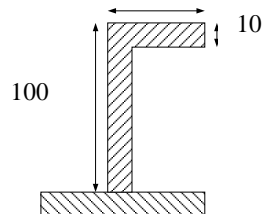

H.6. Web Stiffener pada Sekat

a. Modulus web stiffener sekat tubrukan tidak boleh kurang dari :

PROFILE CONSTRUCTION

TUGAS AKHIR KM "BAHARI JAYA" GC 3805 BRT

$$W = C_s \times e \times l^2 \times P \quad (\text{cm}^3)$$

Dimana :

$$C_s = 0,45 \times 0,886 = 0,40$$

$$e = \text{lebar pembebanan} = 3,125 \text{ m}$$

$$l = \frac{1}{3} (H - h_{db}) \\ = \frac{1}{3} (8,81 - 1,32) = 2,50 \text{ m}$$

$$P_s = 94,44 \text{ KN/m}^2$$

Maka :

$$W = 0,40 \times 3,125 \times (2,5)^2 \times 94,44 \\ = 737,812 \text{ cm}^3$$

Profil yang direncanakan T 290 × 13 FP 130 × 13

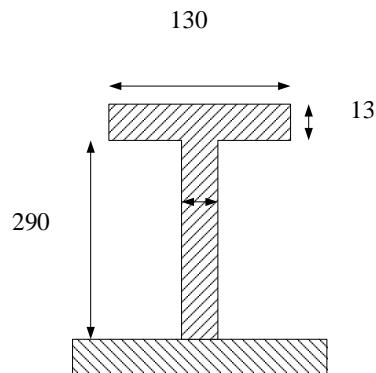

Koreksi modulus

Lebar berguna (40 – 50) = 50

$$f = 13 \times 1,3 = 16,9 \text{ cm}^2$$

$$f_s = 29 \times 1,3 = 37,7 \text{ cm}^2$$

$$F = 50 \times 0,8 = 40 \text{ cm}^2$$

$$f/F = 0,42$$

$$f_s/F = 0,94$$

$$w = 0,64$$

$$W = w \times F \times h \\ = 0,64 \times 40 \times 29 \\ = 742,4 \text{ cm}^3$$

PROFILE CONSTRUCTION

TUGAS AKHIR KM "BAHARI JAYA" GC 3805 BRT

W rencana > W perhitungan

$$742,4 > 737,812 \quad (\text{memenuhi})$$

b. Web stiffener daerah buritan kapal :

$$C_s = 0,36 \times 0,886 = 0,318$$

$$W = C_s \times e \times l^2 \times P \times k \quad (\text{cm}^3)$$

$$= 0,318 \times 3,125 \times (2,5^2) \times 79,42 \times 1$$

$$= 493,272 \text{ cm}^3$$

Profil yang direncanakan T 280 x 9 FP 130 x 9

Lebar berguna (40 – 50) = 50

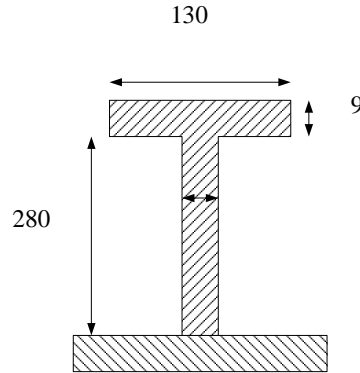

$$f = 13 \times 0,9 = 11,7 \text{ cm}^2$$

$$f_s = 28 \times 0,9 = 20,2 \text{ cm}^2$$

$$F = 50 \times 0,7 = 35 \text{ cm}^2$$

$$f/F = 0,33$$

$$f_s/F = 0,72$$

$$w = 0,51$$

$$W = w \times F \times h$$

$$= 0,51 \times 35 \times 28$$

$$= 499,8 \text{ cm}^3$$

W rencana > W perhitungan

$$499,8 > 493,272 \quad (\text{memenuhi})$$

c. Web stiffener tengah kapal :

PROFILE CONSTRUCTION

TUGAS AKHIR KM "BAHARI JAYA" GC 3805 BRT

$$\begin{aligned}W &= 0,318 \times 3,125 \times (2,5^2) \times 65,97 \times 1 \\ &= 409,735 \text{ cm}^3\end{aligned}$$

Profil yang direncanakan T 250 x 9 FP 120 x 9

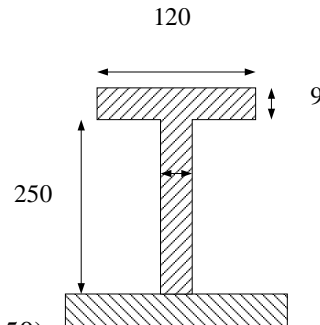

Lebar berguna $(40 - 50) = 50$

$$f = 12 \times 0,9 = 10,8 \text{ cm}^2$$

$$f_s = 25 \times 0,9 = 22,5 \text{ cm}^2$$

$$F = 50 \times 0,7 = 35 \text{ cm}^3$$

$$f/F = 0,31$$

$$f_s/F = 0,64$$

$$w = 0,47$$

$$\begin{aligned}W &= w \times F \times h \\ &= 0,47 \times 35 \times 25\end{aligned}$$

$$= 411,25 \text{ cm}^3$$

W rencana > W perhitungan

$$411,25 > 409,735 \quad (\text{memenuhi})$$

I. BRACKET

Untuk bracket biasanya digunakan untuk menghubungkan dua buah profil, yang mana diatur oleh bagian yang lebih kecil. (BKI 2006 Sec. 3 D.2.2)

1) Tebal dari bracket tidak boleh kurang dari : (tidak pakai flange)

$$\begin{aligned}t &= c \times \sqrt[3]{\frac{W}{k1}} + tk \\ &= 1,2 \times \sqrt[3]{\frac{W}{k1}} + tk\end{aligned}$$

2) Tebal dari bracket tidak boleh kurang dari : (pakai flange)

$$t = c \times \sqrt[3]{\frac{W}{k1}} + tk$$
$$= 0,95 \times \sqrt[3]{\frac{W}{k1}} + tk$$

- a) Tebal bracket antara gading utama (main frame) dengan balok geladak (deck beam) :

$$t = 1,2 \times \sqrt[3]{\frac{86,958}{1,0}} + 1,5$$

$$t = 6,8 \text{ mm diambil } 7 \text{ mm}$$

$$t \text{ min} = 6,5 \text{ mm}$$

Panjang lengan (l)

$$= 50,6 \times \sqrt[3]{\frac{W \cdot k2}{t \cdot k1}}$$
$$= 50,6 \times \sqrt[3]{\frac{86,958 \times 0,886}{7 \times 1,0}}$$

$$= 112,555 \text{ mm}$$

$$l \text{ min} = 100 \text{ mm}$$

$$\text{direncanakan} = 200 \times 7$$

- b) Tebal bracket antara gading utama (main frame) dengan inner bottom :

$$t = 1,2 \times \sqrt[3]{\frac{86,958}{1,0}} + 1,5$$

$$t = 6,816 \text{ mm diambil } 7 \text{ mm}$$

$$t \text{ min} = 6,5 \text{ mm}$$

Panjang lengan (l)

$$= 50,6 \times \sqrt[3]{\frac{86,958 \times 0,886}{7 \times 1,0}}$$

$$= 112,555 \text{ mm}$$

$$l \text{ min} = 100 \text{ mm}$$

$$\text{direncanakan} = 150 \times 7$$

PROFILE CONSTRUCTION

TUGAS AKHIR KM "BAHARI JAYA" GC 3805 BRT

- c) Tebal bracket antara gading utama (main frame) dengan balok geladak (deck beam) pada bangunan atas :

$$t = 1,2 \times \sqrt[3]{\frac{50,450}{1,0}} + 1,5$$

$$t = 5,934 \text{ mm diambil } 7 \text{ mm}$$

$$t \text{ min} = 6,5 \text{ mm}$$

Panjang lengan (l)

$$= 50,6 \times \sqrt[3]{\frac{W \cdot k2}{t \cdot k1}}$$

$$= 50,6 \times \sqrt[3]{\frac{50,450 \times 0,886}{7 \times 1,0}}$$

$$= 93,874 \text{ mm}$$

$$l \text{ min} = 100 \text{ mm}$$

$$\text{direncanakan} = 150 \times 7$$

J. Tebal Plat Linggi Haluan (sec.13)

$$t = (0,6 + 0,4ab) + (0,08L + 6) \sqrt{k} \text{ mm}$$

$$t_{\text{max}} = 25 \sqrt{k} \text{ mm}$$

$$ab = 1,25L \text{ cm}^2$$

$$= 0,25 \times 98,68$$

$$= 123,35 \text{ cm}^2$$

$$t = (0,6 + 0,4ab) + (0,08L + 6) \sqrt{k}$$

$$= (0,6 + 0,4 \times 123,35) + (0,08 \times 98,68 + 6) \sqrt{1}$$

$$= 49,94 + 13,89$$

$$= 63,83 \text{ mm}$$

Diambil $t_{\text{max}} = 25 \text{ mm}$

Dimulai dari 600 diatas garis air, tebal plat dikurangi 0,8t

$$t = 0,8 \times 25 = 20 \text{ mm}$$